

Linea HS 32k CMOS TDI Cameras

Monochrome CMOS TDI HL-HM-32K15S-00-R

sensors | **cameras** | frame grabbers | processors | software | vision solutions

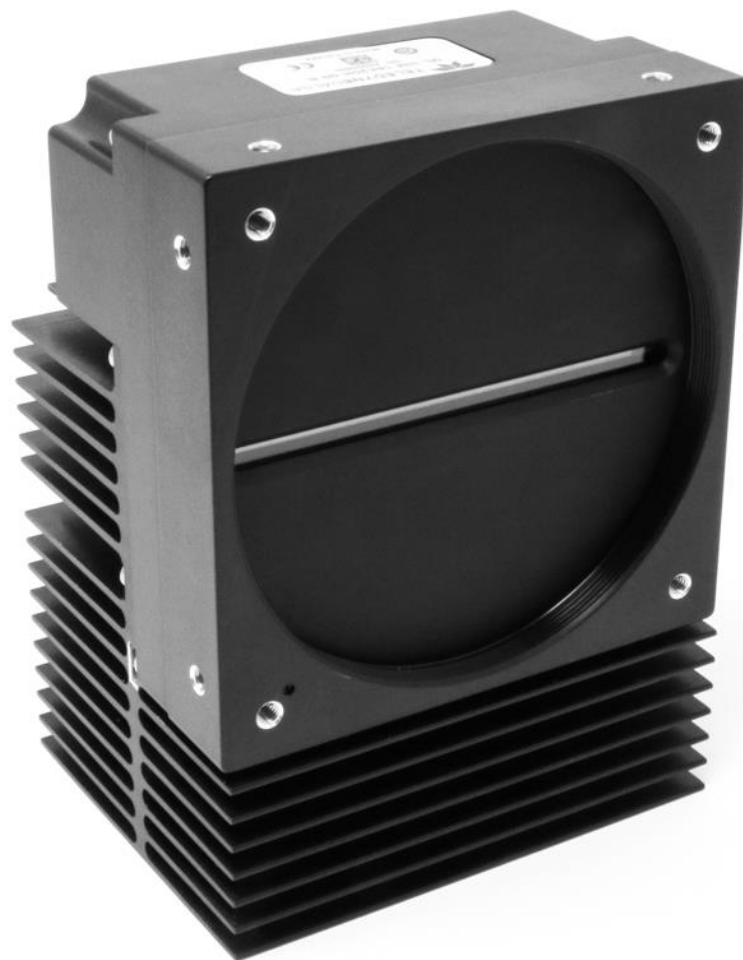

03-032-20290-00
www.teledynedalsa.com

CAMERA
LinkHS™

 **TELEDYNE DALSA**
Everywhereyoulook™

Part of the Teledyne Imaging Group

© 2019 Teledyne Digital Imaging, Inc.

All information provided in this manual is believed to be accurate and reliable. No responsibility is assumed by Teledyne DALSA for its use. Teledyne DALSA reserves the right to make changes to this information without notice. Reproduction of this manual in whole or in part, by any means, is prohibited without prior permission having been obtained from Teledyne DALSA.

Microsoft and Windows are registered trademarks of Microsoft Corporation in the United States and other countries. Windows, Windows 7, Windows 8 are trademarks of Microsoft Corporation.

All other trademarks or intellectual property mentioned herein belong to their respective owners.

Document Date: 20 November 2019
Document Number: 03-032-20290-00

About Teledyne DALSA

Teledyne DALSA, a business unit of Teledyne Digital Imaging Inc., is an international high performance semiconductor and Electronics Company that designs, develops, manufactures, and markets digital imaging products and solutions, in addition to providing wafer foundry services.

Teledyne DALSA offers the widest range of machine vision components in the world. From industry-leading image sensors through powerful and sophisticated cameras, frame grabbers, vision processors and software to easy-to-use vision appliances and custom vision modules.

Contact Teledyne DALSA

Teledyne DALSA is headquartered in Waterloo, Ontario, Canada. We have sales offices in the USA, Europe and Asia, plus a worldwide network of representatives and agents to serve you efficiently. Contact information for sales and support inquiries, plus links to maps and directions to our offices, can be found here:

Sales Offices: <http://www.teledynedalsa.com/corp/contact/offices/>

Technical Support: <http://www.teledynedalsa.com/imaging/support/>

*****THIS IS AN UNCONTROLLED COPY OF A CONTROLLED DOCUMENT*****

The information contained herein is proprietary to Teledyne DALSA and is to be used solely for the purpose for which it is supplied.

It shall not be disclosed in whole or in part, to any other party, without the express permission in writing by Teledyne DALSA

Contents

TABLES	5
FIGURES	6
THE LINEA HS 32K TDI CAMERA	7
DESCRIPTION	7
CAMERA HIGHLIGHTS	8
<i>Key Features</i>	8
<i>Programmability</i>	8
<i>Applications</i>	8
PART NUMBERS AND SOFTWARE REQUIREMENTS	9
SPECIFICATIONS	10
<i>Camera Performance</i>	10
<i>Performance ¹⁾</i>	11
<i>Environmental Specifications</i>	11
<i>Flash Memory Size</i>	11
<i>Certification & Compliance</i>	11
<i>Responsivity & QE</i>	12
<i>Camera Input Power</i>	12
CAMERA PROCESSING CHAIN	13
SUPPORTED INDUSTRY STANDARDS	13
<i>GenICam™</i>	13
<i>Camera Link HS</i>	14
<i>CX4 AOC Data Cables</i>	14
MECHANICAL DRAWING	15
PRECAUTIONS	16
<i>Electrostatic Discharge and the CMOS Sensor</i>	16
INSTALL & CONFIGURE FRAME GRABBER & SOFTWARE	17
<i>Using Sopera CamExpert</i>	17
<i>CamExpert Panes</i>	18
SETTING UP FOR IMAGING	20
<i>Camera I / O Connectors</i>	20
<i>Powering the Camera</i>	20
<i>Power and GPIO Connections</i>	21
<i>External Input Electrical Characteristics</i>	22
<i>Establishing Camera Communications</i>	24
<i>Selecting the Data Format</i>	24
<i>Establishing Data Integrity</i>	24
CAMERA PERFORMANCE AND FEATURES	25
SYNCHRONIZING TO OBJECT MOTION	25
<i>Acquiring Images: Triggering the Camera</i>	25
<i>Measuring Line (Trigger) Rate</i>	26
<i>Maximum Line Rate</i>	26
<i>Minimum Line Rate</i>	26
<i>Scan Direction</i>	26
<i>Camera Orientation</i>	28
<i>Spatial Alignment</i>	29

IMAGING MODES	30
<i>32k Super Resolution Modes</i>	30
<i>32k SR Mapped</i>	30
<i>32k SR Detail Restored</i>	30
<i>TDI Mode</i>	30
<i>Area Mode</i>	31
<i>Extended Area Mode</i>	31
<i>Internal Trigger Mode</i>	31
ESTABLISHING THE DESIRED RESPONSE	32
<i>Exposure Control by Light Source Strobe</i>	32
<i>Image Response Uniformity & Flat Field Calibration</i>	34
<i>Saving & Loading a PRNU Set Only</i>	35
<i>Setting Custom Flat Field Coefficients</i>	35
<i>Flat Field Calibration Filter</i>	36
<i>Flat Field Calibration Regions of Interest</i>	36
IMAGE FILTERS	37
<i>Kernels</i>	37
<i>Image Filter Contrast Ratio</i>	37
CUSTOMIZED LINEARITY RESPONSE (LUT)	38
<i>How to Generate LUT with CamExpert</i>	38
Important points:	39
ADJUSTING RESPONSIVITY AND CONTRAST ENHANCEMENT	40
SAVING & RESTORING CAMERA SETUP CONFIGURATIONS	41
<i>Active Settings for Current Operation</i>	42
<i>User Setting</i>	42
<i>Factory Settings</i>	43
<i>Default Setting</i>	43
APPENDIX A: GENICAM COMMANDS	44
CAMERA INFORMATION CATEGORY	45
<i>Camera Information Feature Descriptions</i>	45
<i>Built-In Self-Test Codes (BIST)</i>	48
<i>Camera Power-Up Configuration Selection Dialog</i>	48
<i>Camera Power-up Configuration</i>	48
<i>User Set Configuration Management</i>	49
CAMERA CONTROL CATEGORY	50
<i>Camera Control Feature Descriptions</i>	50
<i>Digital I / O Control Feature Descriptions</i>	52
<i>Digital I/O Control Feature Descriptions</i>	52
<i>Rotary Encoder Direction</i>	52
FLAT FIELD CATEGORY	54
<i>Flat Field Control Feature Description</i>	54
IMAGE FORMAT CONTROL CATEGORY	57
<i>Image Format Control Feature Description</i>	57
FILE ACCESS CONTROL CATEGORY	60
<i>File Access Control Feature Descriptions</i>	60
<i>File Access via the CamExpert Tool</i>	62
<i>CLHS File Transfer Protocol</i>	63
Upload File to Camera	64
<i>Download a List of Camera Parameters</i>	64
TRANSPORT LAYER CONTROL CATEGORY	65
<i>Transport Layer Feature Descriptions</i>	65
ACQUISITION AND TRANSFER CONTROL CATEGORY	67

<i>Acquisition and Transfer Control Feature Descriptions</i>	67
APPENDIX B: TROUBLE SHOOTING GUIDE	68
DIAGNOSTIC TOOLS	68
RESOLVING CAMERA ISSUES	70
<i>Communications</i>	70
<i>Image Quality Issues</i>	71
<i>Power Supply Issues</i>	73
<i>Causes for Overheating & Power Shut Down</i>	74
DECLARATION OF CONFORMITY	75
DOCUMENT REVISION HISTORY	76
CONTACT INFORMATION	77
SALES INFORMATION	77
TECHNICAL SUPPORT	77

Tables

<i>Table 1: Available Camera Models</i>	7
<i>Table 2: Camera Models Comparison</i>	9
<i>Table 3: Frame Grabber</i>	9
<i>Table 4: Software</i>	9
<i>Table 5: Camera Performance Specifications</i>	10
<i>Table 6: Environmental Specifications</i>	11
<i>Table 7: Camera Flash Memory Size</i>	11
<i>Table 8: Camera Certification & Compliance</i>	11
<i>Table 9: 12-pin Hirose pin assignment</i>	21
<i>Table 10: External Input Electrical Characteristics</i>	22
<i>Table 11: External Timing Reference</i>	22
<i>Table 12: External Output Electrical Characteristics</i>	22
<i>Table 13: External Output Timing Reference</i>	22
<i>Table 14: Status LED States</i>	24
<i>Table 15: Maximum Line Rate</i>	26
<i>Table 16: TDI Mode Internal Trigger Rate</i>	31
<i>Table 17: BIST Codes</i>	69
<i>Table 18: Status LED States</i>	69
<i>Table 19: Document Revision History</i>	76

Figures

Figure 1: Spectral Responsivity & QE, 32k SR Mapped, 1x gain	12
Figure 2. HL-HM-32K15S-00-R Power Vs. Input Voltage	12
Figure 3: Digital data processing chain.....	13
Figure 4. Single CLHS Connector Configuration	14
Figure 5: HL-HM-32K15S-00-R Mechanical Drawing.....	15
Figure 6. CamExpert Frame Grabber Control Window.....	18
Figure 7. Camera I / O Connectors	20
Figure 8: 12-pin Hirose Pin Numbering.....	21
Figure 9: GPIO cable accessory #CR-GENC-IOP00.....	23
Figure 10. Image with incorrect scan direction	27
Figure 11: Example of Object Movement and Camera Direction.....	28
Figure 12. Camera array spacing and usage	29
Figure 13 Strobe Timing.....	32
Figure 14 GPIO functionality block diagram	33
Figure 15: 1 x 3 kernel	37
Figure 16: 1 x 5 kernel	37
Figure 17: CamExpert LUT Creation Dialog	39
Figure 18. Relationship between the Camera Settings.....	42
Figure 19 Example CamExpert Camera Information Panel	45
Figure 20 CamExpert Power-Up Configuration Dialog	48
Figure 21: Camera Control Panel.....	50
Figure 22 Digital I/O Control Panel	52
Figure 23: Flat Field Panel	54
Figure 24: Image Format Panel.....	57
Figure 25: Alignment Markers.....	59
Figure 26: File Access Control Panel	60
Figure 27: File Access Control Tool	62
Figure 28: Transport Layer Panel	65
Figure 29: Acquisition & Transfer Control Panel.....	67

The Linea HS 32k TDI Camera

Description

Teledyne DALSA introduces a breakthrough CMOS TDI line scan camera format with unprecedented speed, responsivity, and exceptionally low noise.

The Linea HS 32k camera is capable of capturing 32,768 pixel wide images with a patent-pending sensor design that enables users to significantly improve subpixel defect detectability while using existing optical lenses.

The camera uses the Camera Link HS™ interface—the industry standard for very high speed camera interfaces with long transmission distances and up to 8.4 GByte/sec data in a single cable.

Teledyne DALSA's Linea HS 32k camera and the Xtium2-CLHS PX8-HR frame grabber combine to offer a complete solution for the next generation of automatic optical inspection (AOI) systems.

This camera is recommended for detecting small defects at high speeds and over a large field of view in LCD and OLED flat panel displays, DNA sequencing, printed circuit boards, film, and large format web materials.

Available Camera Models

Table 1: Available Camera Models

Part Number	Description
HL-HM-32K15S-00-R	32,768 pixels x 64, maximum line rate of 150 kHz, 5 µm x 5 µm pixel size, monochrome output, Camera Link HS CX4 control & data connector.

Camera Highlights

Key Features

- Highly sensitive CMOS TDI
- 32k super pixel resolution (Proprietary)
- 150 kHz line rate
- Improved subpixel detectability
- Very low noise
- Bi-directionality
- High speed fiber optic interface
- High dynamic LUT mode

Programmability

- Region of interest for easy calibration of lens and shading correction
- Smart lens shading correction
- Test patterns & diagnostics

Applications

- Flat panel LCD and OLED display inspection
- Web inspection
- Printed circuit board inspection
- Pathology
- DNA sequencing
- High throughput and high resolution applications

Part Numbers and Software Requirements

The camera is available in the following configurations:

Table 2: Camera Models Comparison

Part Number	Resolution	Max. Line Rates	Pixel Size	Control & Data
HL-HM-32K15S-00-R	32,768 pixels x 64	150 kHz	5.0 x 5.0 μm	Camera Link HS CX4

Table 3: Frame Grabber

Compatible Frame grabber	HL-HM-32K15S
Teledyne DALSA	Xtium2-CLHS PX8-HR (OR-A8S0-HX870)*

*Required for custom patent-pending pixel processing: HL-HM-32K15S-00-R is currently only compatible with this frame grabber.

Table 4: Software

Software	Product Number / Version Number
Camera firmware	Embedded within camera
GenICam™ support (XML camera description file)	Embedded within camera
Sapera LT, including CamExpert GUI application and GenICam for Camera Link imaging driver	Latest version on the TeledyneDALSA Web site

Specifications

Camera Performance

Table 5: Camera Performance Specifications

Specifications	HL-HM-32K15S	Notes
Imager Format	High speed CMOS TDI	
Resolution	32,768 pixels x 64	16k dual array
Pixel Size	5.0 μm x 5.0 μm	2.5 μm effective pixel pitch
Pixel Fill Factor	100%	
Line Rate, maximum	150 kHz	32k Super Resolution modes
	300 kHz	16k TDI modes
Bit Depth	8 bit	
Connectors and Mechanicals	HL-HM-32K15S	Notes
Control & Data Interface	Camera Link HS CX4	
Power	+12 V to +24 V DC, Hirose 12-pin circular	
Typical Power Dissipation	28 W	
Size	Width	76 mm
	Height	97 mm
	Depth	140.5 mm
Mass	1.2 kg	Cross-Scan direction In-Scan direction Along optical axis
Operating Temp	+0 °C to +65°C	front plate temperature
Optical Interface	HL-HM-32K15S	Notes
Lens Mount	M90 x 1 mm	
Sensor to Camera Front Distance	12 mm	
Sensor Alignment		Relative to sides of camera
Flatness	50 μm	
Θ y	100 μm	Parallelism vs. front plate
x	\pm 300 μm	Cross-Scan Direction
y	\pm 300 μm	In-Scan Direction
z	\pm 300 μm	Along optical axis
Θ z	\pm 0.4°	Rotation around optical axis

Performance ¹⁾	HL-HM-32K15S	Notes
Random Noise	< 0.1 DN rms (16 e ⁻)	Typical ²⁾
Peak Responsivity	250 DN/nJ/cm ²	@670 nm
Digital Gain	1x to 10x	
Analog Gain	1x, 2x, 4x or 8x	
DC Offset	0 DN	Adjustable
Dynamic Range	70 dB	Typical ²⁾
Full Well	50,000 e ⁻	Typical
PRNU	< ±2%	At 50% saturation ^{3,4)}
DSNU (FPN)	< ±2 DN	
SEE	1 nJ/cm ²	At 670 nm
NEE	< 0.4 pJ/cm ²	At 670 nm
Integral non-linearity	< 2%	

1) Test Conditions unless otherwise specified:

- 8 bit, 1x gain
- 100 kHz line rate
- Light source: White LED if wavelength not specified
- Front plate temperature: +45° C
- DN = digital number

2) Random Noise below quantization limit cannot be measured accurately; use higher gain for comparison purposes

3) Calibration at 80% saturation, measurements at 50% saturation

4) Light sources vary spectrally and spatially: re-calibrate cameras in actual system

5) Specifications not guaranteed when operating in area mode

Environmental Specifications

Table 6: Environmental Specifications

Environmental Specifications	
Storage temperature range	-20 °C to +80 °C
Humidity (storage and operation)	15% to 85% relative, non-condensing
MTBF (mean time between failures)	>100,000 hours, typical field operation

Flash Memory Size

Table 7: Camera Flash Memory Size

Camera	Flash memory size
All models	4 GByte

Certification & Compliance

Table 8: Camera Certification & Compliance

Compliance
See the Declaration of Conformity section at the end of this manual.

Responsivity & QE

The following graphs show the spectral responsivity and QE in 32k super resolution mode; for 16k modes, multiply responsivity values by 2.

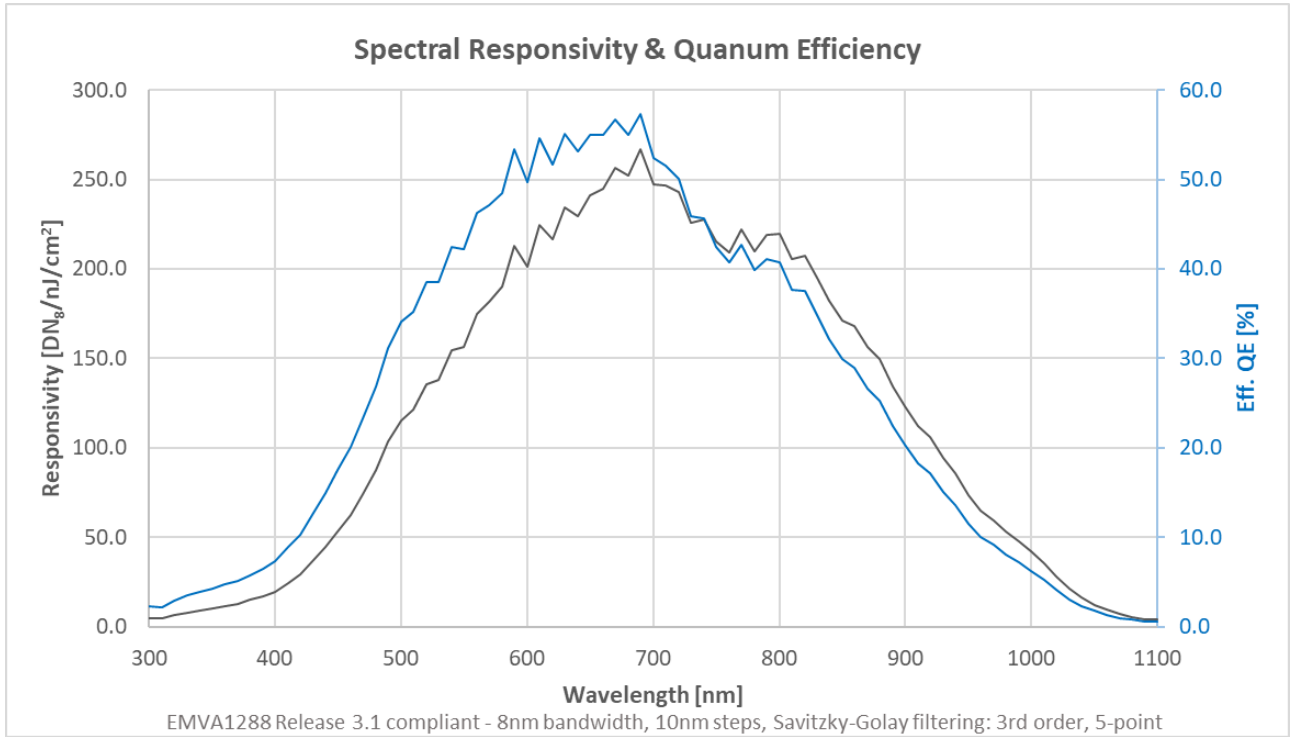

Figure 1: Spectral Responsivity & QE, 32k SR Mapped, 1x gain

Camera Input Power

The following graphs detail the power vs. input voltage for the HL-HM-32K15S-00-R

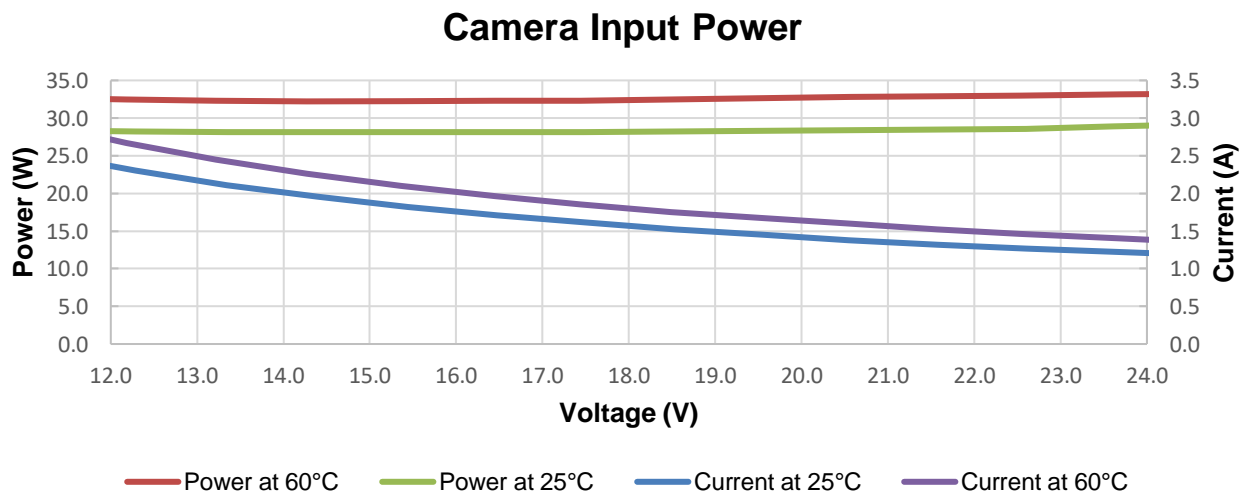

Figure 2. HL-HM-32K15S-00-R Power Vs. Input Voltage

Test conditions: Max line rate—300 kHz, TDI Mode—128, Bit Mode—8, Black Level—31, Temperature—Ambient

Camera Processing Chain

The diagram below details the sequence of user-adjustable, arithmetic operations performed on the camera's sensor data. These adjustments are using camera features outlined in the 'Review of Camera Performance and Features' section.

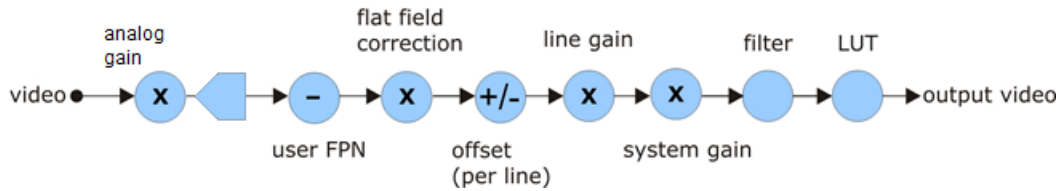

Figure 3: Digital data processing chain

Supported Industry Standards

GenICam™

The camera is GenICam compliant and implements a superset of the GenICam Standard Features Naming Convention specification V1.5.

This description takes the form of an XML device description file using the syntax defined by the GenApi module of the GenICam specification. The camera uses the GenICam Generic Control Protocol (GenCP V1.0) to communicate over the Camera Link HS command lane.

For more information see www.genicam.org.

Camera Link HS

The camera is Camera Link HS version 1.0 compliant. Camera Link HS is the next generation of high performance communications standards. It is used where an industrial digital camera interfaces with a single or multiple frame grabbers and with data rates exceeding those supported by the standard Camera Link.

A CX4 connector is used allowing for output of up to seven lanes. The 32k Linea HS camera uses five of the available seven lanes.

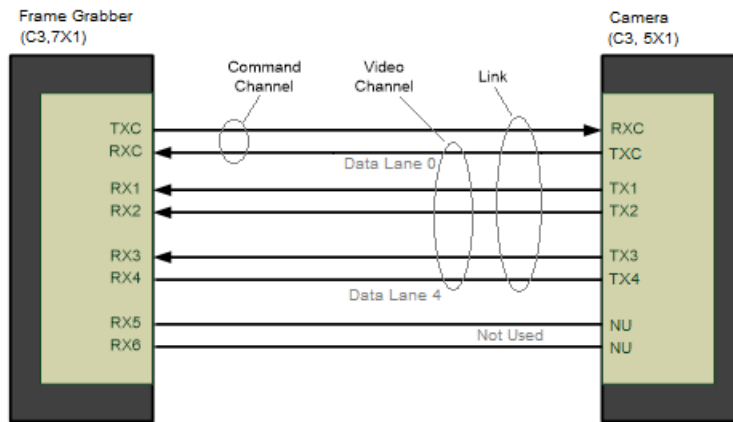

Figure 4. Single CLHS Connector Configuration

The command channel is used by the frame grabber to send commands, configuration, and programming data to the camera and to receive command responses, status, and image data from the camera. Data and command transmission is done with CLHS X protocol (64b / 66b) at the default speed of 10 Gbps.

Note that high speed data transmission limits the effective distance of copper-based cables.

CX4 AOC Data Cables

Camera Link HS CX4 AOC (Active Optical Cable) cables handle very high data rates over long distances. These cables accept the same electrical inputs as traditional copper cables, but use optical fibers for data transmission. AOC uses electrical-to-optical conversion on the cable ends to improve speed and distance performance of the cable without sacrificing compatibility with standard electrical interfaces.

Camera Link HS cables can be bought from OEMs, both in standard and flex models. Please refer to Teledyne DALSA's website (www.teledynedalsa.com) for a list of recommended cable vendors and for part numbers.

Each data cable is used for sending image data to and accepting command data from the frame grabber. Command data includes GenICam compliant messages, trigger timing, and general purpose I/O, such as direction control.

Mechanical Drawing

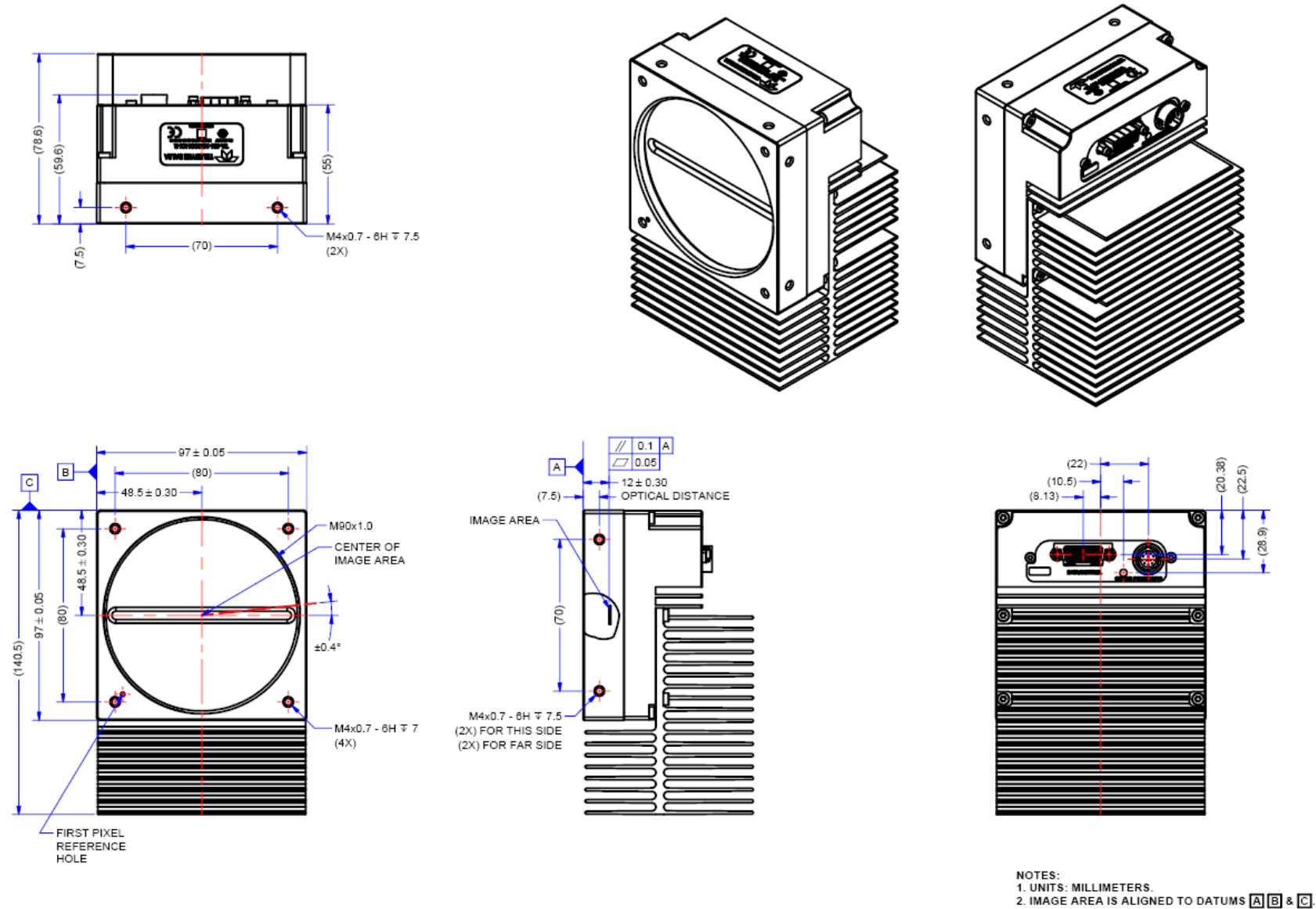

Figure 5: HL-HM-32K15S-00-R Mechanical Drawing

Precautions



Read these precautions before using the camera.

Confirm that the camera's packaging is undamaged before opening it. If the packaging is damaged please contact the related logistics personnel.

Do not open the housing of the camera. The warranty is voided if the housing is opened.

Keep the camera's front plate temperature in a range of 0 °C to +65 °C during operation. The camera has the ability to measure its internal temperature. Use this feature to record the internal temperature of the camera when it is mounted in your system and operating under the worst case conditions. The camera will stop outputting data if its internal temperature reaches +80 °C.

Do not operate the camera in the vicinity of strong electromagnetic fields. In addition, avoid electrostatic discharging, violent vibration, and excess moisture.

To clean the device, avoid electrostatic charging by using a dry, clean absorbent cotton cloth dampened with a small quantity of pure alcohol. Do not use methylated alcohol. To clean the surface of the camera housing, use a soft, dry cloth. To remove severe stains use a soft cloth dampened with a small quantity of neutral detergent and then wipe dry. Do not use volatile solvents such as benzene and thinners, as they can damage the surface finish.

Though this camera supports hot plugging, it is recommended that you power down and disconnect power to the camera before you add or replace system components.

Electrostatic Discharge and the CMOS Sensor

Image sensors and the camera's housing can be susceptible to damage from severe electrostatic discharge (ESD). Electrostatic charge introduced to the sensor window surface can induce charge buildup on the underside of the window. The charge normally dissipates within 24 hours and the sensor returns to normal operation.

Install & Configure Frame Grabber & Software

The camera requires a Teledyne DALSA frame grabber due to high-bandwidth and custom patent-pending pixel processing; currently the camera is supported exclusively by Xtium2-CLHS PX8 HR (OR-A8S0-HX870).

A GenICam compliant XML device description file is embedded with the camera firmware. It allows GenICam compliant applications to recognize the camera's capabilities, once connected.

Installing Sopera LT gives you access to the CamExpert GUI, a GenICam compliant application.

Using Sopera CamExpert

CamExpert is the camera interfacing tool supported by the Sopera library. When used with the camera, CamExpert allows a user to test all camera operating modes. In addition, CamExpert can be used to save the camera's user settings configurations to the camera or to save multiple configurations as individual camera parameter files on the host system (*.ccf). CamExpert can also be used to upgrade the camera's software.

An important component of CamExpert is its live acquisition display window. This window allows verification of timing or control parameters in real-time, without need for a separate acquisition program.

Note: In a change from previous versions of the Sopera GUI, only one instance of CamExpert is required to send commands to the camera and view images.

For context sensitive help, click on the  button and then click on a camera configuration parameter.

A short description of the configuration parameter will be shown in a popup. Click on the  button to open the help file for more descriptive information on CamExpert.

The central section of CamExpert provides access to the camera features and parameters.



Note: The availability of features depends on the CamExpert user setting. Not all features are available to all users. The examples shown are for illustrative purposes and may not entirely reflect the features and parameters available from the camera model used in your application.

CamExpert Panes

CamExpert, first instance: select Camera Link HS using the Device drop-down menu.

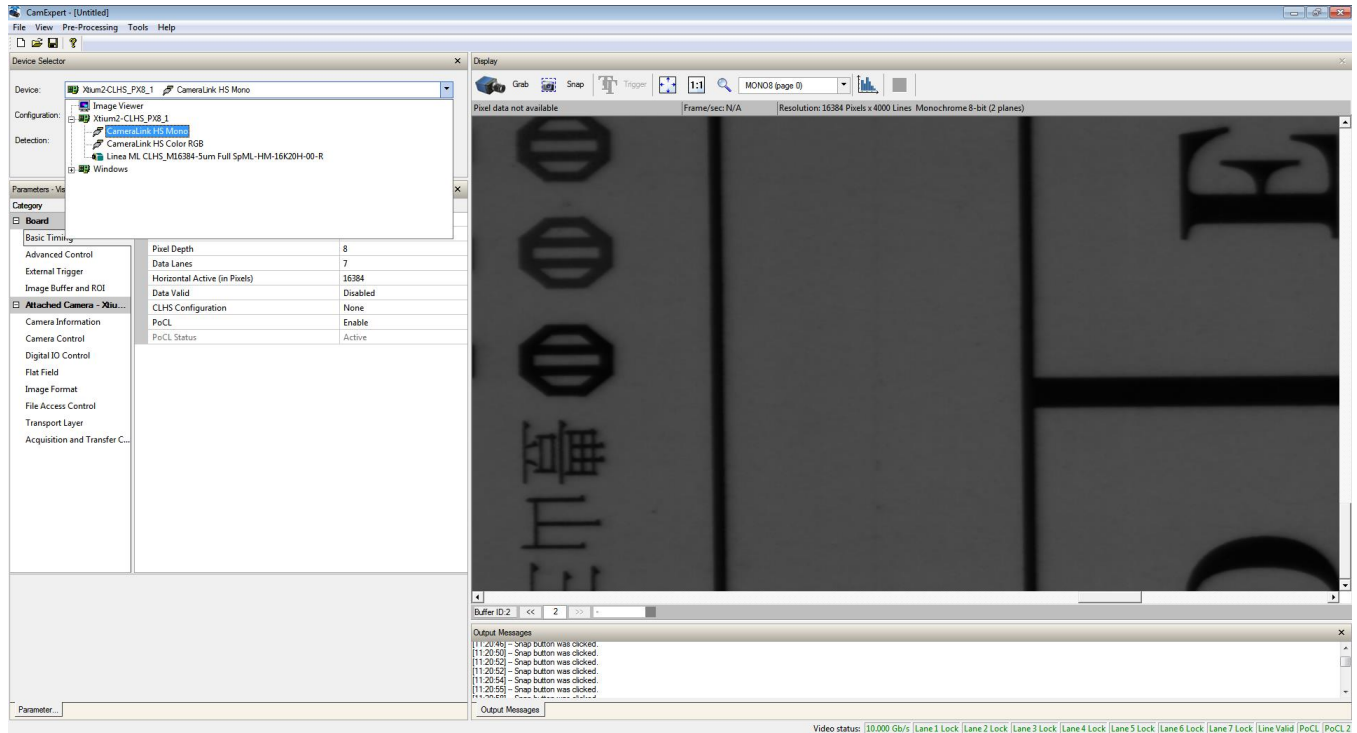

Figure 6. CamExpert Frame Grabber Control Window







The CamExpert application uses panes to organize the selection and configuration of camera files or acquisition parameters.

Device Selector pane: View and select from any installed Sapera acquisition device. Once a device is selected, CamExpert will only show acquisition parameters for that device. Optionally, select a camera file included with the Sapera installation or saved previously.

Parameters pane: Allows the viewing or changing of all acquisition parameters supported by the acquisition device. CamExpert displays parameters only if those parameters are supported by the installed device. This avoids confusion by eliminating parameter choices when they do not apply to the hardware in use.

Display pane: Provides a live or single frame acquisition display. Frame buffer parameters are shown in an information bar above the image window.

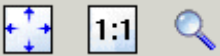
Control Buttons: The display pane includes CamExpert control buttons. These are:

 Grab  Freeze	<p>Acquisition control button: Click once to start live grab, click again to stop.</p>
 Snap	<p>Single frame grab: Click to acquire one frame from device.</p>
 Trigger	<p>Trigger button: With the I/O control parameters set to Trigger Enabled, click to send a single trigger command.</p>
	<p>CamExpert display controls: (these do not modify the frame buffer data) Stretch image to fit, set image display to original size, or zoom the image to virtually any size and ratio.</p>
	<p>Histogram / Profile tool: Select to view a histogram or line/column profile during live acquisition or in a still image.</p>

Output Message Pane: Displays messages from CamExpert or the device driver.

At this point you are ready to start operating the camera, acquire images, set camera functions, and save settings.

Setting Up for Imaging

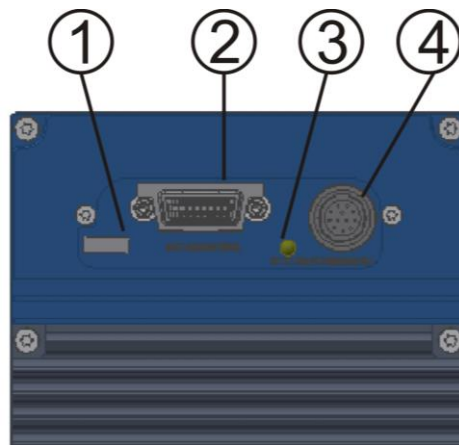

Figure 7. Camera I / O Connectors

Camera I / O Connectors

- 1) Factory use only
- 2) Data and control connectors - CX4
- 3) LED status indicators
- 4) Power and GPIO connectors: +12 V to +24 V DC, Hirose 12-pin circular

Powering the Camera



WARNING: When setting up the camera's power supply follow these guidelines:

- Apply the appropriate voltages of between +12 V to +24 V. Incorrect voltages may damage the camera.
- Before connecting power to the camera, test all power supplies.
- Protect the camera with a 3 amp slow-blow fuse between the power supply and the camera.
- Do not use the shield on a multi-conductor cable for ground.
- Keep leads as short as possible in order to reduce voltage drop.
- Use high quality supplies in order to minimize noise.
- When using a 12 V supply, voltage loss in the power cables will be greater due to the higher current. Use the Camera Information category to refresh and read the camera's input voltage measurement. Adjust the supply to ensure that it reads above or equal to 12 V.



Note: If your power supply does not meet these requirements, then the camera performance specifications are not guaranteed.

Power and GPIO Connections

The camera uses a single 12-pin Hirose male connector for power, trigger, and strobe signals. The suggested female cable mating connector is the *Hirose model HR10A-10P-12S*.

12-Pin Hirose Connector Signal Details

The following figure shows the pinout identification when looking at the camera's 12-pin male Hirose connector. The table below lists the I/O signal connections.

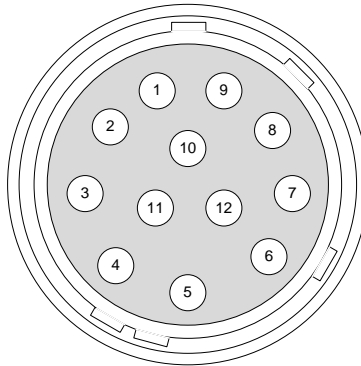

Figure 8: 12-pin Hirose Pin Numbering

Table 9: 12-pin Hirose pin assignment

Pin Number	Input / Output	Signal Details	Notes
1		Power Ground	
2		+12 V to +24 V power	
3	Output	Line 3 Out	0 to 3.3 V TTL
4	Output	Line 4 Out	0 to 3.3 V TTL
5	Input	Line 1/ Trigger / Phase A	0 to 3.3 V TTL
6	Input	Line 2 / Scan Direction/Phase B	0 to 3.3 V TTL
7	Output	Line 5 Out	0 to 3.3 V TTL
8	Output	Line 6 Out	0 to 3.3 V TTL
9		Power Ground	
10		+12 V to +24 V power	
11		Signal Ground	Note: intended as a return path for GPIO signal and not intended as a power ground
12		Signal Ground	Note: intended as a return path for GPIO signal and not intended as a power ground

The wire gauge of the power cable should be sufficient to accommodate a surge during power-up of at least 3 amps with a minimum voltage drop between the power supply and camera. The camera can accept any voltage between +12 and +24 Volts. If there is a voltage drop between the power supply and camera, ensure that the power supply voltage is at least 12 Volts plus this voltage drop. The camera input supply voltage can be read using CamExpert. Refer to the section on Voltage & Temperature Measurement for more details.

External Input Electrical Characteristics

Table 10: External Input Electrical Characteristics

Input Level Standard	Switching Voltage		Input Impedance
	Low to high	High to low	
3.3 V TTL	2.1 V	1 V	10K Ω

External Input Timing Reference

Table 11: External Timing Reference

Input Level Standard	Maximum Input Frequency	Minimum Pulse Width	Input Current	Maximum Signal Propagation Delay @ 60°C	
				0 to 3.3 V	<100 ns
3.3 V TTL	20 MHz	25 ns	<250 μ A	3.3 V to 0	<100 ns
				0 to 3.3 V	<100 ns

External Output Electrical Characteristics

Table 12: External Output Electrical Characteristics

Output Level Standard	V _{OL}	V _{OH}
3.3 V TTL	<0.4 V @ 10mA*	>3.1 V @ 10mA*

*See Linear Technology data sheet LTC2854

External Output Timing Reference

Table 13: External Output Timing Reference

Output Level Standard	Maximum Output Frequency	Minimum Pulse Width	Output Current	Maximum Signal Propagation Delay @ 60°C	
				0 to 3.3 V	<100 ns
3.3 V TTL	Line rate dependent	25 ns	<180 mA	3.3 V to 0	<100 ns
				0 to 3.3 V	<100 ns



To reduce the chance of stress and vibration on the cables, we recommend that you use cable clamps, placed close to the camera, when setting up your imaging system. Stress or vibration of the heavy CLHS AOC cables may damage the camera's connectors.

Mating GPIO Cable Assembly

An optional GPIO breakout cable (12-pin Female Hirose to 13-Pos Euro Block) is available for purchase from Teledyne DALSA under accessory number #CR-GENC-IOP00 to order.

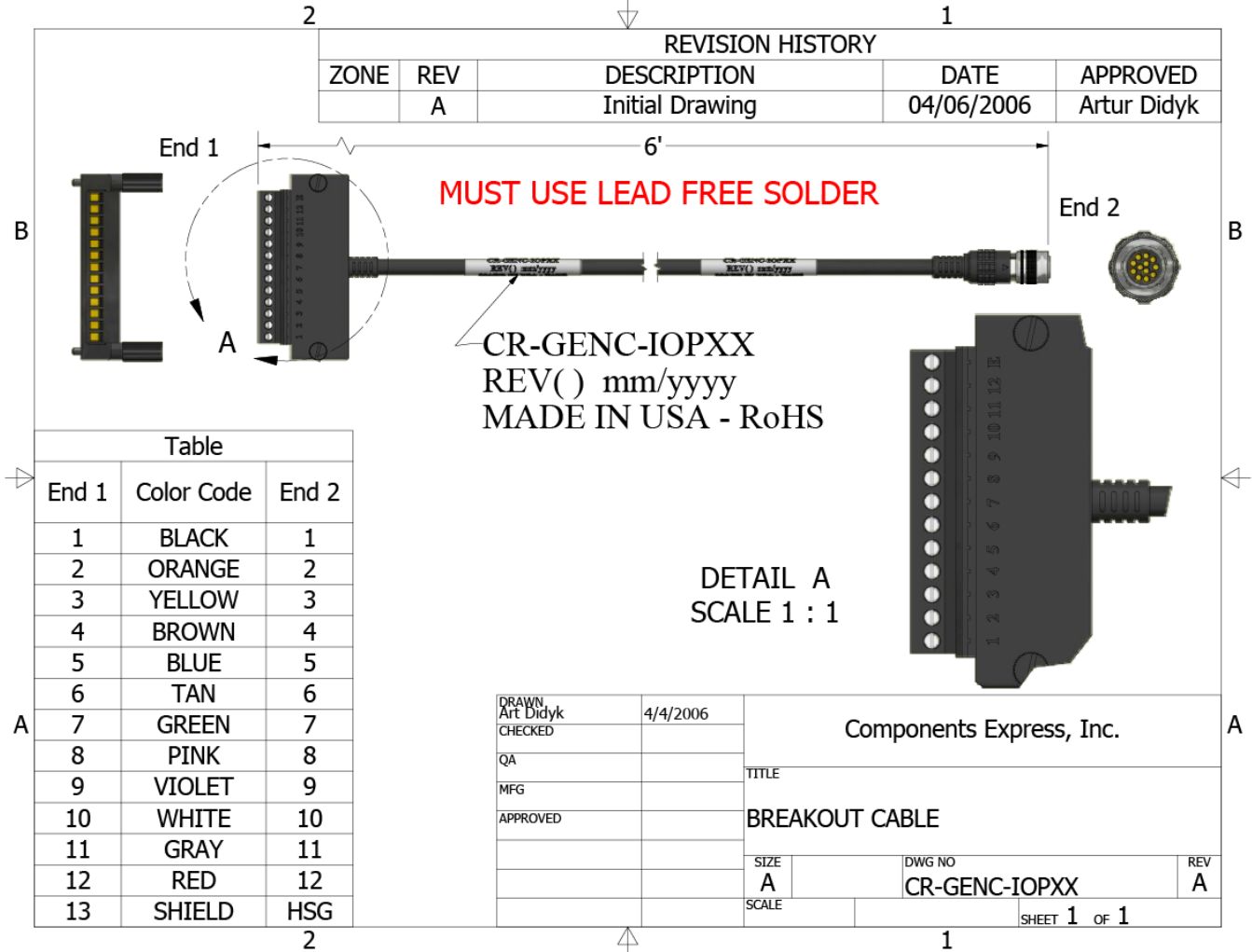

Figure 9: GPIO cable accessory #CR-GENC-IOP00

Establishing Camera Communications

When powering up the camera, the status LED on the back will indicate one of the following conditions:

Table 14: Status LED States

LED State	Description
Off	Camera is not powered up or is waiting for the software to start.
Constant Red	The camera BIST status is not good. See BIST status for diagnosis. CamExpert can be used to get the BIST value from the camera.
Blinking Red	The camera has shut down due to a temperature problem.
Blinking Orange	Powering Up. The microprocessor is loading code.
Blinking Green	Hardware is good but the CLHS connection has not been established or has recently been broken.
Constant Green	The CLHS Link has been established and the camera is ready for data transfer to begin.

When the camera's LED state is steady green open the first instance of CamExpert.

1. CamExpert will search for installed Sopera devices
2. In the Devices list area on the left side of the window, the connected frame grabber will be shown
3. Select the frame grabber device by clicking on the name

Selecting the Data Format

The camera can output data in *Mono8* format.

The camera always outputs data to the frame grabber in a 'planar' format—when multiple arrays are used the corresponding lines are output separately one after the other. Please refer to the frame grabber user's documentation for further details on selection input and output pixel formats.

Establishing Data Integrity

1. Use the camera's internal triggering. This allows for initial imaging with a static object and no encoder input is required.
2. Enable the camera to output a test pattern.
3. Use a frame grabber CamExpert instance to capture, display, and analyze the test pattern image to verify the integrity of the connection. If the test pattern is not correct, check the cable connections and the frame grabber setup.
4. Disable the test pattern output.

Camera Performance and Features

This section is intended to be a progressive introduction to the features of the camera, including explanations of how to use them effectively.

Synchronizing to Object Motion

Acquiring Images: Triggering the Camera

Related Features: [TriggerMode](#), [TriggerSource](#), [TriggerActivation](#)

A number of different methods can be used to trigger image acquisition in the camera:

Internal Trigger

The simplest method is to set the *Trigger Mode* feature to "Internal". This results in the camera being triggered by an internal timer, which can be adjusted using the *Acquisition Line Rate* feature.

External Triggers

When the *Trigger Mode* feature is set to "External", the triggers to the camera can come from different sources, selected through the *Trigger Source* feature.

The available sources for the triggers are from pin 5 of the GPIO connector, from the Camera Link HS frame grabber, or from the rotary encoder feature (using pin 5 and pin 6 of the GPIO connector).

Use the *Trigger Activation* feature to select the edge that triggers the camera. The options are: *Rising Edge*, *Falling Edge* or *Any Edge*. When using *Any Edge* be careful that the time between edges does not exceed the maximum line rate of the camera. If the line rate is exceeded one of those edges will be ignored.

CamExpert can be used to configure the frame grabber for routing the encoder signal from the frame grabber input to the trigger input of the camera via the Camera Link HS data cable.

Line Rate & Synchronization

A continuous stream of encoder trigger pulses, synchronized to the object motion, establishes the line rate. The faster the object's motion is, the higher the line rate. The camera can accommodate triggers up to its specified maximum frequency. If the maximum frequency is exceeded, the camera will continue to output image data at the maximum specified. The result will be that some trigger pulses will be missed and there will be an associated distortion (compression in the scan direction) of the image data. When the line rate returns to or below the maximum specified, then normal imaging will be reestablished.

Measuring Line (Trigger) Rate

See *Camera Control Category* in Appendix A for GenICam features associated with this section and how to use them.

Related Feature: [measuredLineRate](#)

The *Measured Line Rate* command is used to read the line (trigger) rate being applied, externally or internally, to the camera.

Maximum Line Rate

The maximum achievable line rate is determined by the available imaging modes.

Table 15: Maximum Line Rate

Camera Model	Maximum Line Rate (kHz)			
	32k Super Resolution	16k TDI	Area	Extended Area
HL-HM-32K15S-00-R	150 kHz	300 kHz	2 kHz	650 Hz

Minimum Line Rate

The minimum line rate for all camera models is 300 Hz.

Scan Direction

See the section *Camera Control Category* in Appendix A for GenICam features associated with this section and how to use them

Related Features: [sensorScanDirectionSource](#), [sensorScanDirection](#)

A TDI camera model requires the user to indicate to the camera the direction of travel of the object being imaged.

The source of the scan direction is set using the *sensorScanDirectionSource* feature. The options are: *Internal*, *Line 2* (pin 6 on the GPIO connector), or the *rotary encoder* feature (using pin 5 and pin 6 of the GPIO connector, only available when *TriggerSource* is "RotaryEncoder" and *rotaryEncoderOutputMode* is set to "Motion").

When set to *internal*, use the *sensorScanDirection* feature to set the direction.

It is important to perform and save a flat field calibration in the actual system, both directions will be used.

Direction Change Time

The direction change time between forward and reverse is < 1 ms.

Setting the correct scan direction

Whether the scan direction is set correctly can easily be seen in live imaging. An image will appear “normal”, sharp and focused. If the optical setup is not properly focused, blur will occur in both, horizontal (cross-scan) and vertical (in-scan), directions.

If blur occurs only in scan direction (see below), the scan direction is set incorrectly.

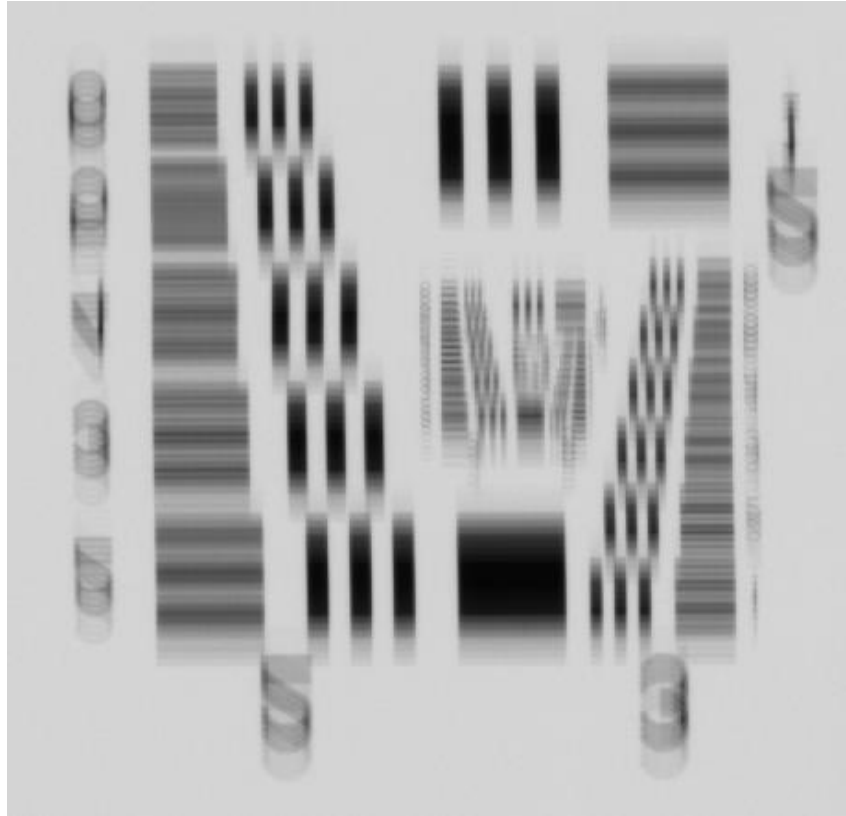

Figure 10. Image with incorrect scan direction

Camera Orientation

The diagram below shows the orientation of forward and reverse with respect to the camera body.



Note: The diagram assumes the use of a lens on the camera, which inverts the image.

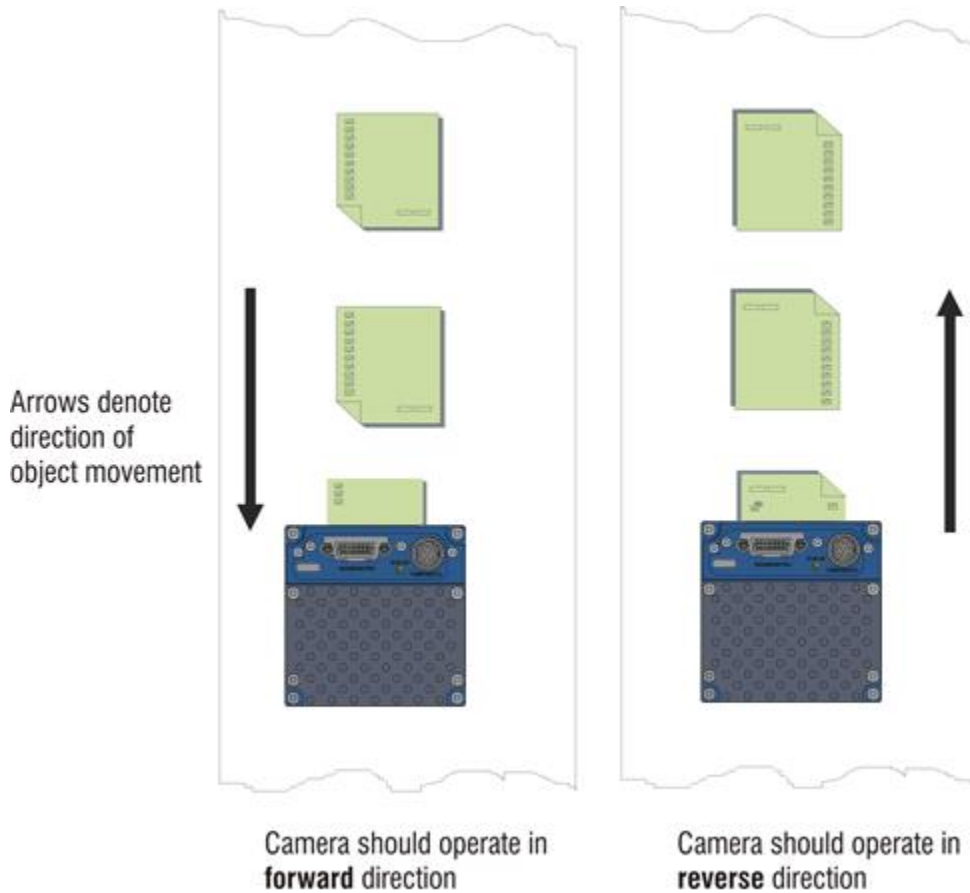

Figure 11: Example of Object Movement and Camera Direction

The diagram shows the designated camera direction. However, due to the characteristics of the lens, the direction of the objects motion is opposite to the image motion direction.

Some AOI systems require that the scan direction change at regular intervals. For example, scanning a panel forwards, coming to a stop, and then scanning backward as the camera's field of view is progressively indexed over the entire panel.

It is necessary for the system to over-scan the area being imaged by at least the 128 stages of the TDI sensor before the direction is changed. This ensures that valid data will be generated on the return path as the camera's field of view reaches the area to be inspected.

Spatial Alignment

The 32k super resolution camera uses multiple sensor arrays of 5µm pixels to combine into a 32k 2.5µm effective pixel pitch super resolution image. The multiple arrays are aligned automatically in the frame grabber using row spacing data provided by the camera.

Related Features: [alignmentMarkerEnable](#), [alignmentMarkerVerticalSpacing](#), [alignmentMarkerVerticalOffset](#), [alignmentMarkerHorizontalSpacing](#), [alignmentMarkerHorizontalOffset](#) and [alignmentMarkerBlack](#)

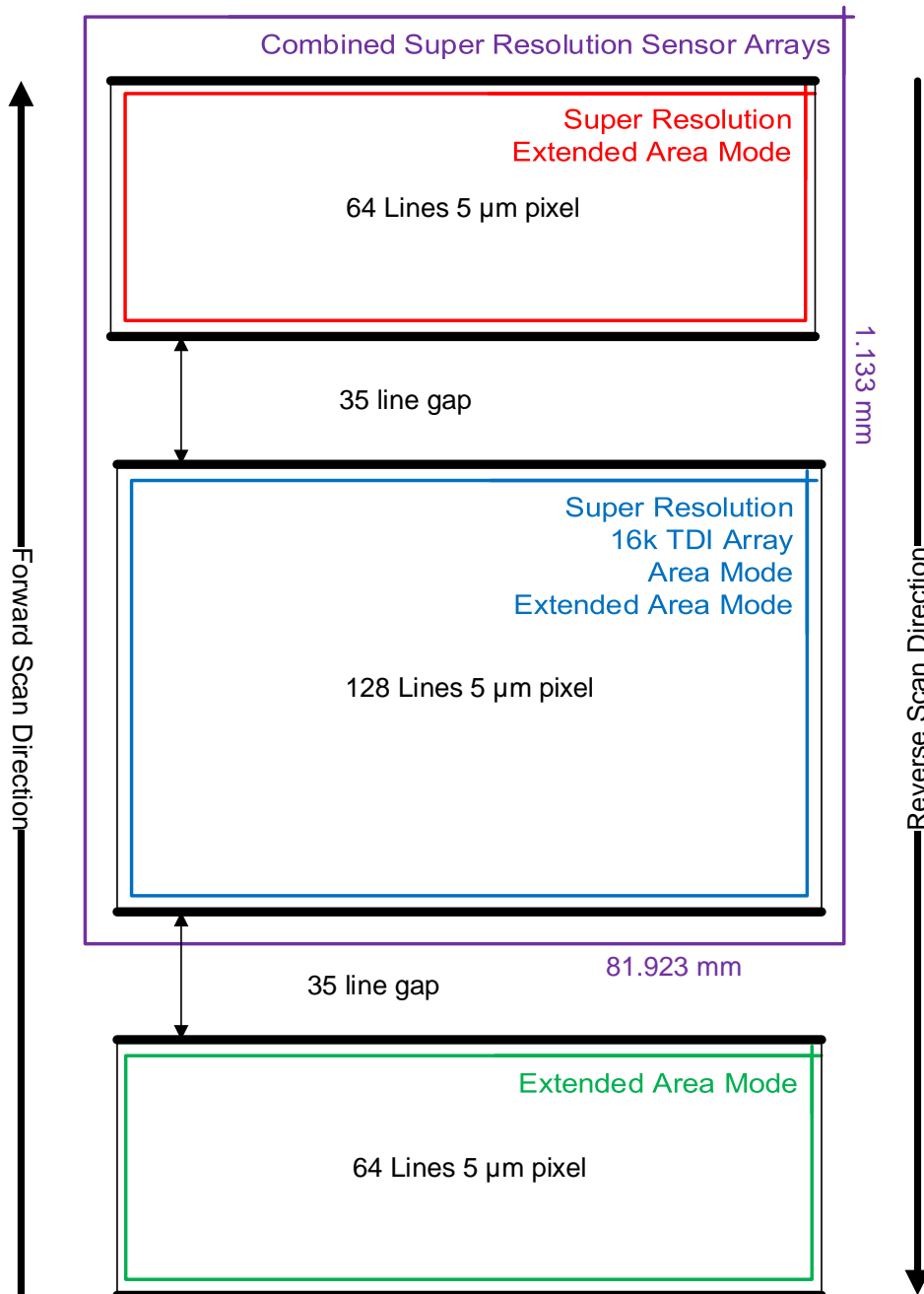

Figure 12. Camera array spacing and usage

Imaging Modes

See the section *Camera Control Category in Appendix A for GenICam features associated with this section and how to use them*

Relevant Features: [sensorTDIModeSelection](#), [sensorTDIStagesSelection](#)

The Linea HS 32k is capable of being run in five different modes: 32k SR Detail Restored, 32k SR Mapped, TDI, TDI Area mode and TDI Multi Area.

32k Super Resolution Modes

Unlike typical bilinear or bicubic interpolation methods, Teledyne DALSA's proprietary and patent-pending super resolution system derives a balanced, artifact free 32k image that provides higher detectability, especially for small defects, high MTF (modulation transfer function, also known as spatial frequency response), low noise and high SNR, all with the responsivity of a 5um pixel. The combination of camera, CLHS interface and High-Resolution framegrabber enables this functionality up to 150kHz line rate.

32k SR Mapped

The SR mapped function utilizes the first stage in Teledyne DALSA's patented processing chain. The high resolution image is created, benefitting the system with higher Full Well, higher SNR and lower noise.

This mode provides the lowest level of data processing in the Teledyne DALSA system and hence poses the lowest risk of affecting subsequent user data processing.

Use this mode in the initial setup to evaluate whether your system benefits enough from the 32k SR operation and to avoid conflicts for your algorithms.

32k SR Detail Restored

The Detail Restored mode, when selected, enables the "SR Strength" ([srStrength](#)) parameter for user adjustment.

With "Detail Restored", the full Teledyne DALSA's patented processing chain is activated and sub-pixel information is extracted and enhanced via the "strength" parameter. This function gradually increases the system MTF and provides higher effective SNR for small and sub-pixel defects without affecting noise significantly.

It is highly recommended that the user tests these settings in their own application and adjust the "strength" (between 0 and 1) to identify the best balance between enhanced detection (higher SNR for given defects) and potential false positives that subsequent algorithms may identify.

TDI Mode

TDI mode outputs a lower resolution 16k pixel line (5um pixel pitch without super resolution), allowing twice the responsivity and twice the speed of the 32k modes (2.5um effective pixel pitch with super resolution). TDI mode uses a single 128 stage sensor array. The camera combines multiple exposures of an object as it passes each row in the array into one high sensitivity 16,384 pixel image. A 300 kHz line rate can be achieved in this mode.

Area Mode

In Area Mode, the camera operates as an area array camera (16,384 x 128 pixels) using a two dimensional array of pixels. Area Mode is useful during setup, both for aligning and focusing the camera.

In sufficiently slow applications, area mode can provide a high-aspect 2D image.

When selecting TDI Area mode, the Device Scan Type changes to Area scan and the height feature changes to 128, automatically.

Extended Area Mode

In Extended Area Mode each of the three sensor arrays is output as separate imaging planes. Each output is 16,384 x 128 pixels however as two of the arrays have 64 rows only the bottom half of these images are blank.

Internal Trigger Mode

See the section *Camera Control Category in Appendix A for GenICam features associated with this section and how to use them*

Related Feature: [AcquisitionFrameRate](#), [AcquisitionLineRate](#)

In the different TDI Modes use the following features to set the internal trigger rate:

Table 16: TDI Mode Internal Trigger Rate

TDI Mode	Trigger Rate Feature	Maximum
32k Modes	AcquisitionLineRate	150 kHz
16k TDI	AcquisitionLineRate	300 kHz
Area	AcquisitionFrameRate	2 kHz
Multi Area	AcquisitionFrameRate	650 Hz

Establishing the Desired Response

One of the important performance characteristics of the camera, is its Responsivity and associated noise level at the system's maximum line rate and under desired illumination and lens configuration.

Responsivity and noise performance can be assessed using a stationary, plain white target under bright field illumination. However, to accurately evaluate the camera's real-life performance it is important that the setup is representative of the final system configuration.

The ideal test setup meets the following conditions:

- The lens is in focus, at the desired magnification, and with the desired aperture.
- The illumination intensity is equal to that of the Automatic Optical Inspection (AOI) system and aligned with the camera's field of view.
- The camera is operated with an exposure time that will allow the maximum line rate of the system to be achieved. The camera's internal line rate generator and exposure control can be used for a stationary target.

Exposure Control by Light Source Strobe

Relevant Features: [outputLineSource](#), [outputLinePulseDelay](#), [outputLinePulseDuration](#), [LineInverter](#)



Note: TDI sensors do not have exposure control built in. Pixels continuously convert photons to electrons.

After receiving a line trigger, the camera instructs the sensor to execute the analog read operation. During this time incoming photons are still detected and may associate with the current or subsequent line. This effect is negligible when constant lighting is used.

When using strobed lighting, assure a minimum delay of 1.4 μs between the rising edge of EXSYNC and powering-on of the light source.

Using the GPIO controls the camera can be set up to strobe a light source effectively giving exposure control.

Output Strobe Control Example

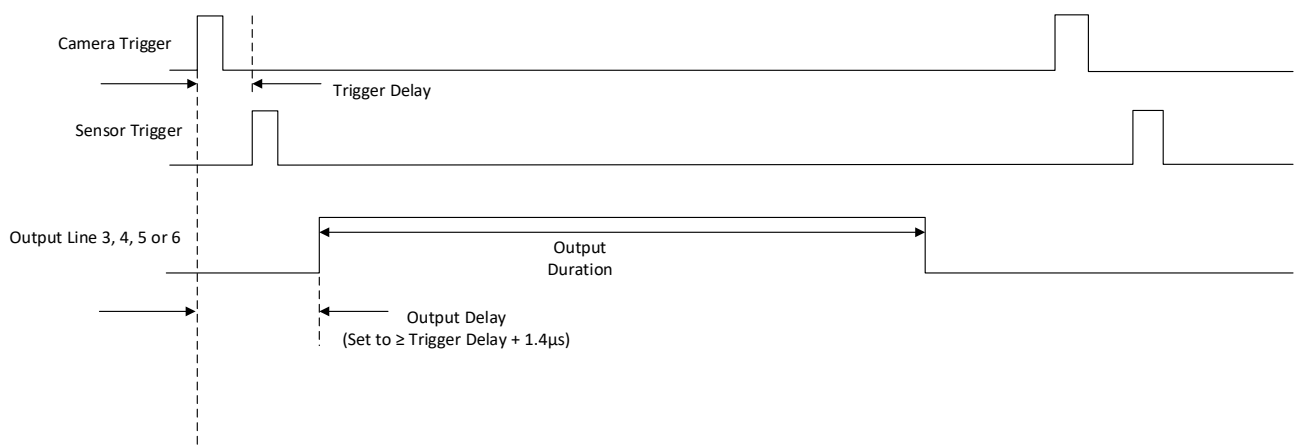

Figure 13 Strobe Timing

The camera logic enables simplified control of external, pulsed light sources to assure reliable timing association.

For this purpose, the trigger signal received from the system is managed by the camera to trigger sensor response and data processing. In addition, an Exposure Active signal is generated and can be supplied to any of the GPIO outputs. This allows triggering or timing external light sources.

Each output line can be programmed against the basic logic and relative to each other through the *ExposureDelay* feature.

The following diagram illustrates the logical control signal flow in the Linea-ML, Linea-HM and Linea-FM camera family.

The [outputLineSource](#), [outputLinePulseDuration](#), [outputLinePulseDelay](#), and [LineInvert](#) features allow the user to control a strobed light source in order to coordinate with the sensor exposure.

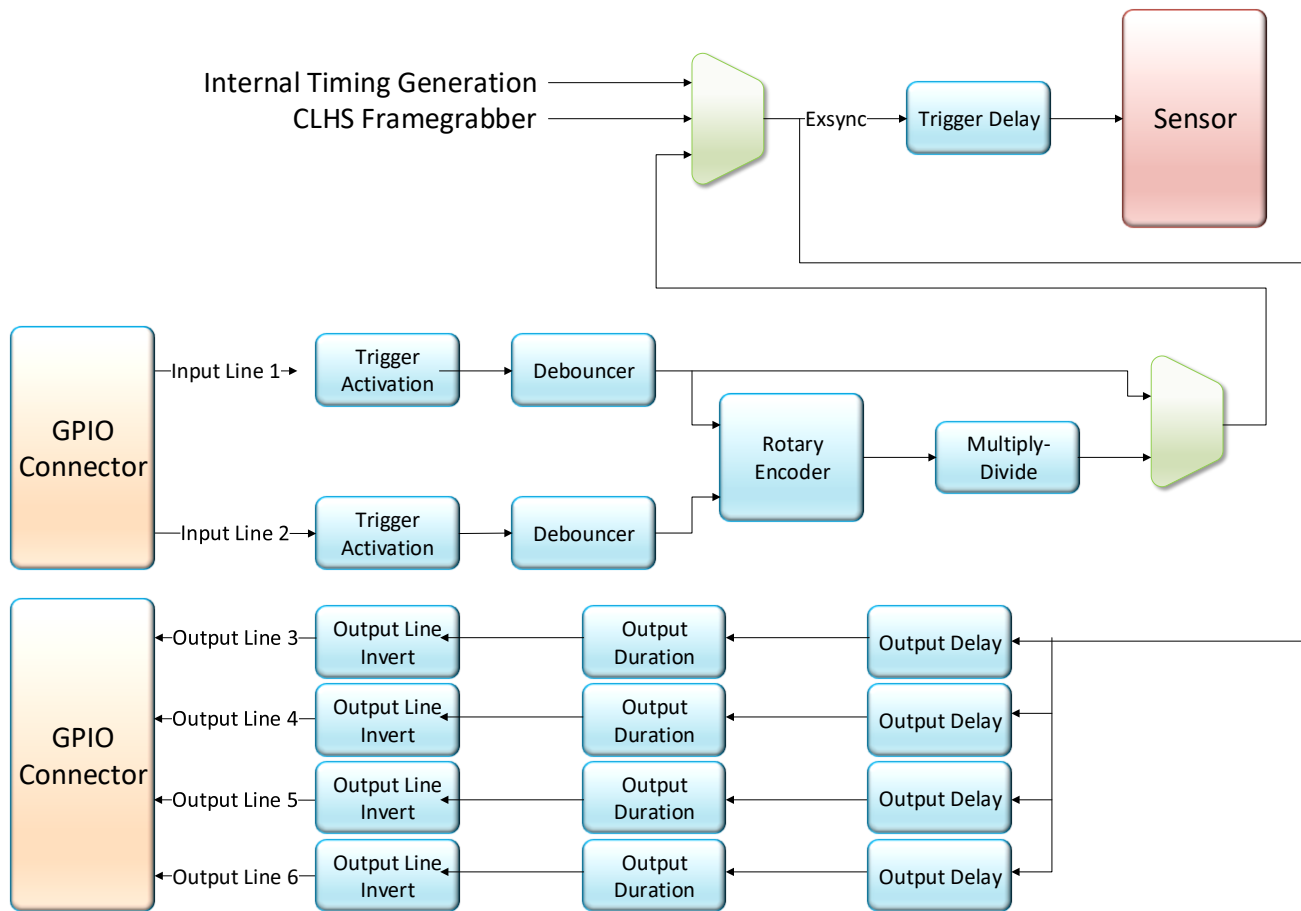

Figure 14 GPIO functionality block diagram

Image Response Uniformity & Flat Field Calibration

See the section *Flat Field Category* in Appendix A for GenICam features associated with this section and how to use them.

Related Features: [flatfieldCalibrateFPN](#), [flatfieldCalibrationPRNU](#), [flatfieldCorrectionAlgorithm](#), [flatfieldCalibrationTarget](#)

Images commonly have lower response at the edges of the camera's field of view compared to its center. This is a result of lens vignetting and structure in the illumination source.

Diffusing elements in the light path removes structure in the illumination and may improve edge-responsivity.

Decreasing the lens aperture can also improve edge-responsivity, if barrel vignetting (a shadow cast on the sensor by the focus helical or extension tubes) is present.

The camera can compensate for edge roll-off and other optical non-uniformities by using flat field calibration.

- When performing Flat Field (PRNU) calibration, the camera should be imaging a front illuminated white target or rear bright field illumination source. The optical setup should be as per the inspection system, including lens magnification, aperture, illumination intensity, spectral content and illuminator beam structure.
- Flat field calibration should be performed when the camera temperature has stabilized.
- Flat field calibration will adjust all pixels to have the same value as the peak pixel value or target level, as per the calibration mode selected.
- If the flat field calibration is set to a target level that is lower than the peak value and the system gain is set to a low value, then it is possible that the sensor will maximize its output before the camera's output reaches 255 DN. This can be seen when a portion of the output stops increasing before reaching 255 DN with increasing illumination and the PRNU deteriorates. This effect can be resolved by decreasing the light level or exposure control time.

Following a flat field calibration, all pixels should be at their un-calibrated peak value or target value. Changing gain values now allows the user to make refinements to the operating responsivity level.



Note: The best flat field calibration can be achieved by performing it at the mid DN level of the working range used in the operation. Any flat field error associated with residual non linearity in the pixel will be halved as compared to performing a calibration at the peak value of the operating range. A simple way of performing this is to reduce exposure time to half what is used in the operation in order to get the mid DN level for flat field calibration. Once complete, return the exposure time to its original setting.

Those areas of the image where high roll-off is present will show higher noise levels after flat field calibration due to the higher gain values of the correction coefficients. Flat field calibration can only compensate for up to an 8:1 variation. If the variation exceeds 8:1 then the line profile after calibration will include pixels that are below the un-calibrated peak level.



Note: The Linea camera has many different modes of operation. It is strongly recommended that the camera be flat fielded for that mode of operation that is intended including direction of scan

Saving & Loading a PRNU Set Only

See the section *Flat Field Category* in *Appendix A* for GenICam features associated with this section and how to use them.

Related Features: [flatfieldCorrectionCurrentActiveSet](#), [flatfieldCalibrationSave](#), [flatfieldCalibrationLoad](#)

A user set includes all the “settings” (for example, gain, line rate), FPN and PRNU coefficients, and a LUT. These three features let you save/load just the PRNU coefficients. Loading a complete user set takes approximately 1 second while loading only the user PRNU coefficients takes less than 200 milliseconds

Use the User PRNU Set Selector parameter to select the set you want to save or load. 17 sets are available—16 user and 1 factory.

The *Factory Set* is read-only and contains all ones. Loading the Factory Set is a good way to clear the user PRNU.

Save the current user PRNU coefficients using the “Save User PRNU Set” command. Load the user PRNU coefficients from the set specified using the “User PRNU Set Selector” and the “Load User PRNU Set” command features.

Setting Custom Flat Field Coefficients

Flat Field (PRNU) coefficients can be custom modified and uploaded to the camera. They can also be downloaded from the camera.

To upload or download coefficients, use *File Access Control Category > Upload / Download File > Settings* and then select *Miscellaneous > Current PRNU* to download / upload a file.

The PRNU coefficients are used by the camera as soon as they are uploaded. To avoid loss at power up or while changing row settings, the uploaded coefficients should be saved to one of the available user sets.

Flat Field Calibration Filter

See the section *Flat Field Category* in Appendix A for GenICam features associated with this section and how to use them

Related Feature: [flatfieldCorrectionAlgorithm](#)

If a sheet of material is being used as a white target, it must be completely free of blemishes and texture.

The presence of dirt or texture will generate a variation in the image that will be incorporated into the calibration coefficients of the camera. Further, once the target is removed, or moved, vertical stripes will be present in the scanned image.

Dirt or texture that has dark characteristics will appear as bright vertical lines. Dirt or texture that has bright characteristics will appear as dark vertical lines.

One way to minimize this effect is to have the white target in motion during the calibration process. This has the result of averaging out any dirt or texture present. If this is not possible, the camera has a feature where a flat field calibration filter can be applied while generating the flat field correction coefficients—which can minimize the effects of dirt.



Note: This filter is only capable of compensating for small, occasional contaminants. It will not overcome large features in a target's texture.

Flat Field Calibration Regions of Interest

See the section *Flat Field Category* in Appendix A for GenICam features associated with this section and how to use them

Related Features: [flatfieldCalibrationROIOffsetX](#), [flatfieldCalibrationROIWidth](#)

There are occasions when the camera's field of view includes areas that are beyond the material to be inspected.

This may occur when cameras image off the edge of a panel or web or when an inspection system is imaging multiple lanes of material. The edge of the material or area between lanes may not be illuminated in the same way as the areas of inspection and, therefore, will cause problems with a flat field calibration.

The camera can accommodate these "no inspection zones" by defining a Region of Interest (ROI) where flat field calibration is performed. Image data outside the ROI is ignored by the flat field calibration algorithm. The ROI is selected by the user and with the pixel boundaries defined by the pixel start address and pixel width and then followed by initiating flat field calibration for that region. Once set, another ROI can be defined and flat field calibrated.

Image Filters

Related Features: [imageFilterMode](#), [imageFilterType](#), [imageFilterKernelSize](#), [imageFilterContrastRatio](#)

The camera has a selection of image filters that can be used to reduce image noise.

Use the feature `imageFilterMode` to turn the filtering on or off. Use the feature `imageFilterType` to read the type of filter that is being used.

Kernels

Use the `ImageFilterKernalSize` feature to select the number of pixels involved in the filter or the kernel size. The options are: 1 x 3 and 1 x 5 filter kernels.

The 1 x 3 and 1 x 5 filter kernels are “weighted average” filters.

The 1 x 3 filter kernel uses 75% of the original pixel and 12.5% of the adjacent pixels.

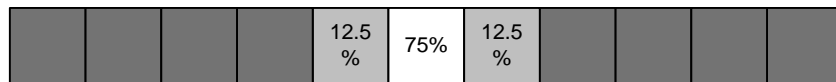

Figure 15: 1 x 3 kernel

The 1 x 5 filter kernel uses 50% of the original pixel and 12.5% of the adjacent two pixels on both sides of the original pixel.

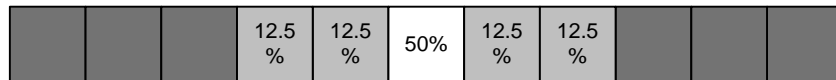

Figure 16: 1 x 5 kernel

Image Filter Contrast Ratio

The image filter contrast ratio feature is used to determine when the filter is applied to the image data. The control looks at the ratio between two adjacent pixels (prior to filter processing) on the sides of the relevant pixel and determines the difference or contrast between those pixels.

If the contrast ratio is greater than the value set by the user, then the filter automatically turns off for those two pixels. If the contrast is below the set value, then the pixel filter is applied.

A value of 0 will turn off the filters for all pixels and a value of 1 will keep the filter on for all pixels.

Customized Linearity Response (LUT)

See the section *Camera Control Category* in Appendix A for GenICam features associated with this section and how to use them

Related Features: [lutMode](#), [gammaCorrection](#)



Note: These features may only be useful in applications that use the frame grabber's Mono Image Buffer Format.

The camera allows the user to access a LUT (Look Up Table) to allow the user to customize the linearity of how the camera responds. This can be done by uploading a LUT to the camera using the file transfer features or by using the `gammaCorrection` feature.

The gamma correction value can be adjusted by the user at any time.

When the LUT is enabled, there is no change in maximum line rate or amount of data output from the camera. The LUT can be used with any mode of the camera. Further, when the LUT is enabled, it is recommended that the fixed Offset available in the Camera Control category be set to zero.

To upload a LUT, use *File Access Control Category* > *Upload / Download File* > *Settings* and select *Look Up Table* to upload a file.

The file format is described in 03-084-20133 Linea Binary File Format which can be obtained from Teledyne DALSA Technical Support. This document also includes Excel spreadsheet examples.

How to Generate LUT with CamExpert

CamExpert can also be used to create a LUT file. The camera uses a 12-bit in / 12-bit out LUT (even though the camera is outputting an 8-bit image). CamExpert can be configured to create a 12-bit in / 16-bit out LUT - the camera will convert it to the required format.

1. Open CamExpert > version 8.40.
2. *Device* should be an *Xtium2* connected to a *Linea* camera.
3. Under *Board* select *Basic Timing* and set *Pixel Depth* to 12.
4. Under *Board* select *Image Buffer and ROI* and set *Image Buffer Format* to *Monochrome 16 bits*
5. Leave *Image Buffer and ROI* selected.
6. In the top menu select *Pre-Processing | Lookup Table* and set *Enable*.
7. In the same menu select *Setting...*
8. Configure the output LUT here by scrolling through the different options under *Value*.
 - a. Some selections have additional parameters to configure (e.g. *Gamma correction* requires a *Correction factor*).
9. Click on the *Save LUT* button to create a LUT file.
10. This file can be loaded into the camera using the *File Access* features. It is saved with the current *Load / Save Configuration* user set; ensure that a user set and not the factory set is selected, otherwise the upload will fail.
11. Deselect the *Lookup Table | Enable* feature.
12. Return CamExpert to *Pixel Depth* = 8, and *Image Buffer* = 8 bits.

Important points:

- The frame grabber must be configured mono 12 bits in, 16 bits out.
- In the Parameters explorer a frame grabber feature must be selected, not a camera feature.
- The Lookup table must be enabled to be created. But should be disabled to use the camera LUT.

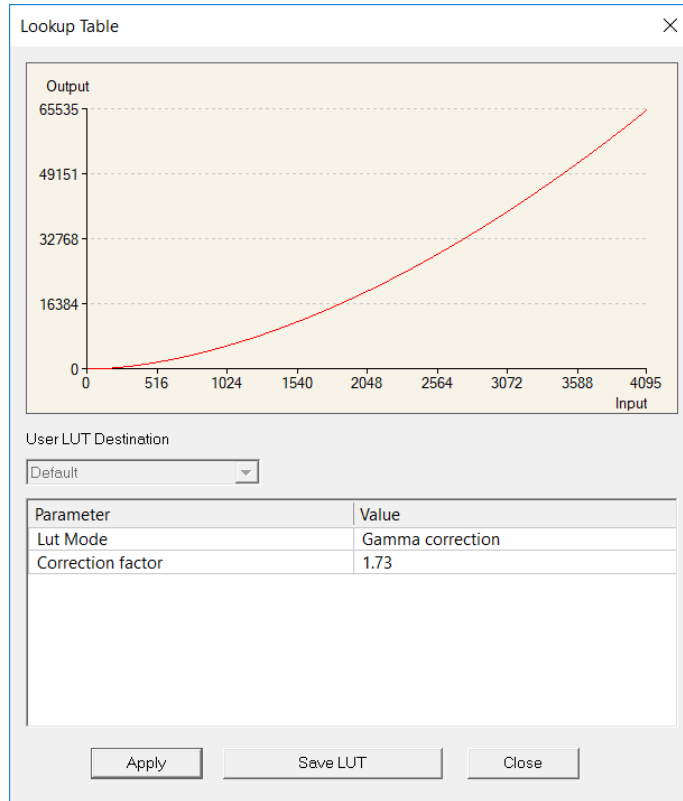

Figure 17: CamExpert LUT Creation Dialog

Adjusting Responsivity and Contrast Enhancement

See the section *Camera Control Category* in Appendix A for GenICam features associated with this section and how to use them.

Related Features: [GainSelector](#), [Gain](#), [BlackLevel](#)

It is best for camera performance to always use the maximum exposure time possible based on the maximum line rate of the inspection system and any margin that may be required to accommodate illumination degradation. However, it will be necessary to adjust the responsivity to achieve the desired output from the camera. The camera has a gain feature that can be used to adjust the camera's responsivity.

Gain adjustment is available to independently adjust each line or all of them together. System Gain can be adjusted from 1 to 10x. Individual line gains can be adjusted from 1 to 4x.

When an image contains no useful dark image data below a specific threshold, then it may be beneficial to increase the contrast of the image.

The camera has an offset feature that allows a specified level to be subtracted from the image data. The gain feature can then be used to return the peak image data to near output saturation with the result being increased image contrast.

First, determine the offset value you need to subtract from the image with the current gain setting you are using. Then set this as a negative offset value and apply additional gain to achieve the desired peak image data values.



Note: A positive offset value is not useful for contrast enhancement. However, it can be used while measuring the dark noise level of the camera to ensure zero clipping is not present.

Saving & Restoring Camera Setup Configurations

See the section *Camera Information Category* in *Appendix A* for GenICam features associated with this section and how to use them

Relevant Features: [UserSetSelector](#), [UserSet1](#) thru [UserSet16](#), [UserSetDefaultSelector](#), [UserSetLoad](#), [UserSetSave](#)

An inspection system may use multiple illumination, resolution, and responsivity configurations in order to cover the different types of inspection it performs.

The camera includes 16 user sets where camera setup information can be saved to and restored from—either at power up, or dynamically during inspection.

The settings active during the current operation can be saved (and thereby become the user setting) using the user set save feature.

A previously saved user setting (User Set 1 to 16) or the factory settings can be restored using the user set selector and user set load features.

Either the factory setting or one of the user settings can be selected as the default setting, by selecting the set in the user set default selector (Camera Power-up configuration option in the Power-up configuration dialog accessed from the Camera Information category). The set selected is selected as the default setting and is the set that is loaded and becomes active when the camera is reset or powered up.

The relationship between these four settings is illustrated in Figure 18. Relationship between the Camera Settings:

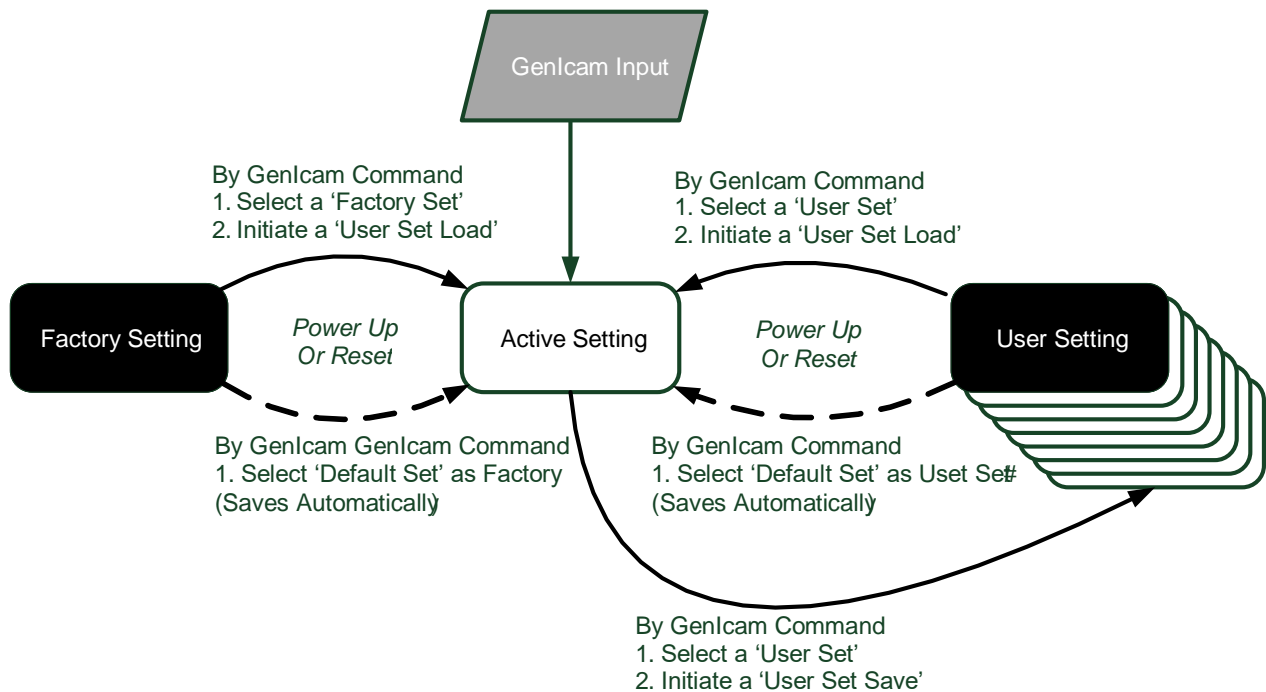

Figure 18. Relationship between the Camera Settings

Active Settings for Current Operation

Active settings are those settings used while the camera is running and include all unsaved changes made by GenICam input to the settings.

These active settings are stored in the camera's *volatile* memory and will be lost and cannot be restored if the camera resets, is powered down, or loses power during operation.

To save these settings so that they can be restored next time you power up the camera, or to protect against losing them in the case of power loss, you must save the current settings using the user set save parameter. Once saved, the current settings become the selected user set.

User Setting

The user setting is the saved set of camera configurations that you can customize, resave, and restore. By default, the user settings are shipped with the same settings as the factory set.

The command user set save saves the current settings to non-volatile memory as a user set. The camera automatically restores the user set configured as the default set when it powers up.

To restore a saved user set, set the user set selector to the set you want to restore and then select the user set load parameter.

Factory Settings

The factory setting is the camera settings that were shipped with the camera and which loaded during the camera's first power-up. To load or restore the original factory settings, at any time, select the factory setting parameter and then select the user set load parameter.



Note: By default, the user settings are set to the factory settings.

Default Setting

Either the factory or one of the user settings can be used as the default setting, by selecting the set to use in the user set default selector. The chosen set automatically becomes the default setting and is the set loaded when the camera is reset or powered up.

Appendix A: GenICam Commands

This appendix lists the available GenICam camera features. The user may access these features using the CamExpert interface or equivalent GUI.

Features listed in the description table but tagged as *Invisible* are typically reserved for Teledyne DALSA Support or third party software usage, and not typically required by end user applications.

The following feature tables describe these parameters along with their view attributes. Additionally the Device Version column will indicate which parameter is a member of the DALSA Features Naming Convention (using the tag **DFNC**), versus the GenICam Standard Features Naming Convention (SFNC tag not shown).

In the CamExpert Panes, parameters in gray are read only, either always or due to another parameter being disabled. Parameters in black are user set in CamExpert or programmable via an imaging application



Note: The CamExpert examples shown for illustrative purposes and may not entirely reflect the features and parameters available from the camera model used in your application

Camera Information Category

Camera information can be retrieved via a controlling application. Parameters such as camera model, firmware version, etc. are read to uniquely identify the connected camera. These features are typically read-only.

The Camera Information Category groups information specific to the individual camera. In this category the number of features shown is identical whether the view is Beginner, Expert, or Guru.

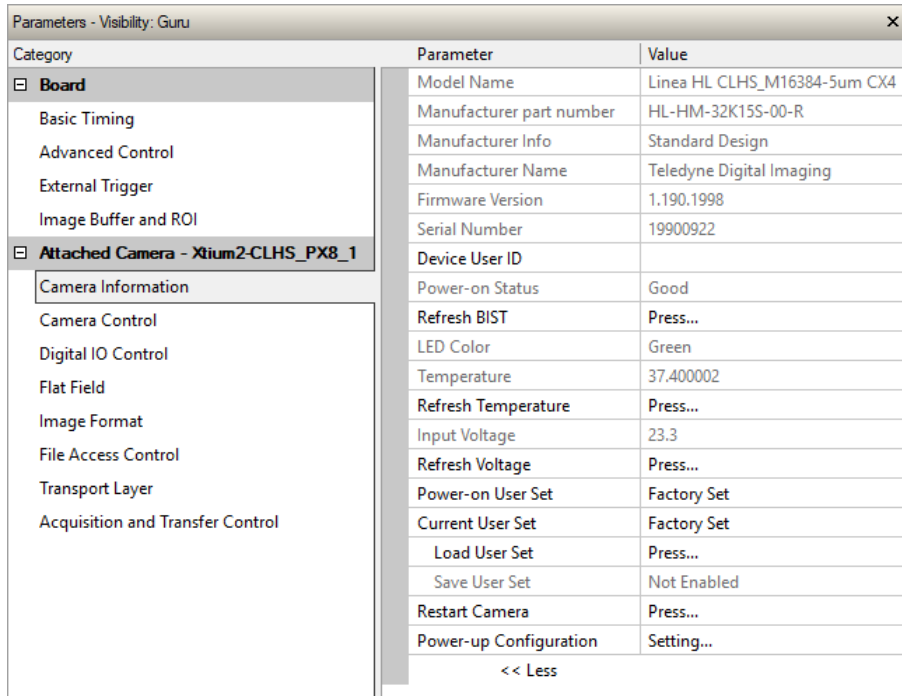

Figure 19 Example CamExpert Camera Information Panel

Camera Information Feature Descriptions

Display Name	Feature	Description	View
Model Name	DeviceModelName	Displays the device model name. (RO)	Beginner
Vendor Name	DeviceVendorName	Displays the device vendor name. (RO)	Beginner
Manufacturer part number	deviceManufacturesPart Number	Displays the device vendor part number. (RO)	Beginner DFNC
Manufacturer Info	DeviceManufacturerInfo	This feature provides extended manufacturer information about the device. Indicates whether standard product or a custom camera(RO)	Beginner
Manufacturer Name	DeviceVendorName	Displays the device vendor name. (RO)	Beginner
Firmware Version	DeviceVersion	Displays the device firmware version. This tag will also highlight if the firmware is a beta or custom design. (RO)	Beginner
Serial Number	DeviceID	Displays the device's factory set camera serial number. (RO)	Beginner
Device User ID	DeviceUserID	Feature to store user-programmable identifier of up to 31 characters. The default factory setting is the camera serial number. (RW)	Beginner

Display Name	Feature	Description	View
Power-on Status	deviceBISTStatus	Determine the status of the device using the 'Built-In Self Test' (BIST). Possible return values are device-specific. (RO) See Built-In Self-Test Codes for status code details	Beginner DFNC
Refresh BIST	deviceBIST	Command to perform an internal test which will determine the device status. (W)	Beginner DFNC
LED Color	deviceLEDColorControl	Select the mode for the LED	Beginner DFNC
<i>Off</i>	<i>Off</i>	<i>Off</i>	
<i>Red</i>	<i>Red</i>	<i>BIST error.</i>	
<i>Green</i>	<i>Green</i>	<i>Operational.</i>	
<i>Waiting for EXSYNC</i>	<i>Fast_Green</i>	<i>4 Hz Green.</i>	
<i>Thermal Shutdown</i>	<i>Medium_Red</i>	<i>2 Hz Red.</i>	
<i>Looking for link</i>	<i>Slow_Green</i>	<i>1 Hz Green.</i>	
<i>Busy</i>	<i>Medium_Orange</i>	<i>2 Hz Orange.</i>	
Temperature	DeviceTemperature	Displays the internal operating temperature of the camera, in Celsius. (RO)	Beginner DFNC
Refresh Temperature	refreshTemperature	Press to update <i>DeviceTemperature</i> .	Beginner DFNC
Input Voltage	deviceInputVoltage	Displays the input voltage to the camera at the power connector (RO)	Beginner DFNC
Refresh Voltage	refreshVoltage	Press to update <i>deviceInputVoltage</i> .	Beginner DFNC
Power-on User Set	UserSetDefaultSelector	Selects the camera configuration set to load and make active on camera power-up or reset. The camera configuration sets are stored in camera non-volatile memory. (RW)	Beginner
<i>Factory Set</i>	<i>Factory</i>	<i>Load factory default feature settings</i>	
<i>UserSet1</i>	<i>UserSet1</i>	<i>Select the user defined configuration UserSet 1 as the Power-up Configuration.</i>	
<i>UserSet2</i>	<i>UserSet2</i>	<i>Select the user defined configuration UserSet 2 as the Power-up Configuration</i>	
<i>UserSet3</i>	<i>UserSet3</i>	<i>Select the user defined configuration UserSet 3 as the Power-up Configuration</i>	
<i>UserSet4</i>	<i>UserSet4</i>	<i>Select the user defined configuration UserSet 4 as the Power-up Configuration.</i>	
<i>UserSet5</i>	<i>UserSet5</i>	<i>Select the user defined configuration UserSet 5 as the Power-up Configuration.</i>	
<i>UserSet6</i>	<i>UserSet6</i>	<i>Select the user defined configuration UserSet 6 as the Power-up Configuration.</i>	
<i>UserSet7</i>	<i>UserSet7</i>	<i>Select the user defined configuration UserSet 7 as the Power-up Configuration.</i>	
<i>UserSet8</i>	<i>UserSet8</i>	<i>Select the user defined configuration UserSet 8 as the Power-up Configuration.</i>	
<i>UserSet9</i>	<i>UserSet9</i>	<i>Select the user defined configuration UserSet 9 as the Power-up Configuration.</i>	
<i>UserSet10</i>	<i>UserSet10</i>	<i>Select the user defined configuration UserSet 10 as the Power-up Configuration.</i>	
<i>UserSet11</i>	<i>UserSet11</i>	<i>Select the user defined configuration UserSet 11 as the Power-up Configuration.</i>	
<i>UserSet12</i>	<i>UserSet12</i>	<i>Select the user defined configuration UserSet 12 as the Power-up Configuration.</i>	

Display Name	Feature	Description	View
<i>UserSet13</i>	<i>UserSet13</i>	Select the user defined configuration <i>UserSet 13</i> as the Power-up Configuration.	
<i>UserSet14</i>	<i>UserSet14</i>	Select the user defined configuration <i>UserSet 14</i> as the Power-up Configuration.	
<i>UserSet15</i>	<i>UserSet15</i>	Select the user defined configuration <i>UserSet 15</i> as the Power-up Configuration.	
<i>UserSet16</i>	<i>UserSet16</i>	Select the user defined configuration <i>UserSet 16</i> as the Power-up Configuration.	
Current User Set	UserSetSelector	Selects the camera configuration set to load feature settings from or save current feature settings to. Points to which user set (1-16) or factory set that is loaded or saved when the UserSetLoad or UserSetSave command is used. The Factory set contains default camera feature settings and is read-only. (RW)	Beginner
<i>Factory Set</i>	<i>Factory</i>	Select the default camera feature settings saved by the factory	
<i>UserSet 1</i>	<i>UserSet1</i>	Select the User-defined Configuration space <i>UserSet1</i> to save to or load from features settings previously saved by the user.	
<i>UserSet 2</i>	<i>UserSet2</i>	Select the User-defined Configuration space <i>UserSet2</i> to save to or load from features settings previously saved by the user.	
<i>UserSet3</i>	<i>UserSet3</i>	Select the User-defined Configuration space <i>UserSet3</i> to save to or load from features settings previously saved by the user.	
<i>UserSet4</i>	<i>UserSet4</i>	Select the User-defined Configuration space <i>UserSet4</i> to save to or load from features settings previously saved by the user.	
<i>UserSet5</i>	<i>UserSet5</i>	Select the User-defined Configuration space <i>UserSet5</i> to save to or load from features settings previously saved by the user.	
<i>UserSet6</i>	<i>UserSet6</i>	Select the User-defined Configuration space <i>UserSet6</i> to save to or load from features settings previously saved by the user.	
<i>UserSet7</i>	<i>UserSet7</i>	Select the User-defined Configuration space <i>UserSet7</i> to save to or load from features settings previously saved by the user.	
<i>UserSet8</i>	<i>UserSet8</i>	Select the User-defined Configuration space <i>UserSet8</i> to save to or load from features settings previously saved by the user.	
<i>UserSet9</i>	<i>UserSet9</i>	Select the User-defined Configuration space <i>UserSet9</i> to save to or load from features settings previously saved by the user.	
<i>UserSet10</i>	<i>UserSet10</i>	Select the User-defined Configuration space <i>UserSet10</i> to save to or load from features settings previously saved by the user.	
<i>UserSet11</i>	<i>UserSet11</i>	Select the User-defined Configuration space <i>UserSet11</i> to save to or load from features settings previously saved by the user.	
<i>UserSet12</i>	<i>UserSet12</i>	Select the User-defined Configuration space <i>UserSet12</i> to save to or load from features settings previously saved by the user.	

Display Name	Feature	Description	View
<i>UserSet13</i>	<i>UserSet13</i>	Select the User-defined Configuration space <i>UserSet13</i> to save to or load from features settings previously saved by the user.	
<i>UserSet14</i>	<i>UserSet14</i>	Select the User-defined Configuration space <i>UserSet14</i> to save to or load from features settings previously saved by the user.	
<i>UserSet15</i>	<i>UserSet15</i>	Select the User-defined Configuration space <i>UserSet15</i> to save to or load from features settings previously saved by the user.	
<i>UserSet16</i>	<i>UserSet16</i>	Select the User-defined Configuration space <i>UserSet16</i> to save to or load from features settings previously saved by the user.	
Load User Set	UserSetLoad	Loads the camera configuration set specified by the User Set Selector feature, to the camera and makes it active. (W)	Beginner
Save User Set	UserSetSave	Saves the current camera configuration to the user set specified by the User Set Selector feature. The user sets are located on the camera in non-volatile memory. (W)	Beginner

Built-In Self-Test Codes (BIST)

In the Camera Information screen shot example above, the Power-On Status is showing “Good”, indicating that the camera powered up without any problems.

Details of the BIST codes can be found in the Trouble Shooting Guide in Appendix B.

Camera Power-Up Configuration Selection Dialog

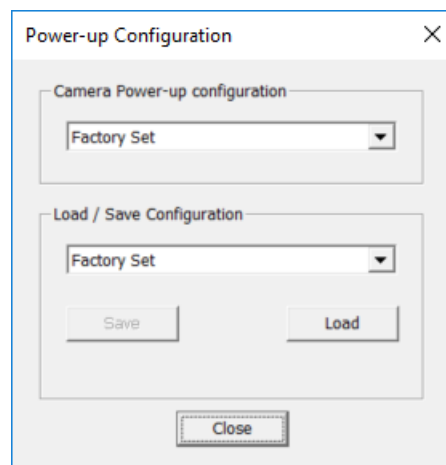

Figure 20 CamExpert Power-Up Configuration Dialog

CamExpert provides a dialog box which combines the GemICam features used to select the camera’s power-up state and for the user to save or load a camera state as a specific user set that is retained in the camera’s non-volatile memory.

Camera Power-up Configuration

The first drop list selects the camera configuration set to load on power-up (see feature *UserSetDefaultSelector*). The user chooses the factory data set or from one of 16 available user-saved states.

User Set Configuration Management

The second drop list allows the user to change the camera configuration any time after a power-up (see feature *UserSetSelector*). To reset the camera to the factory configuration, select *Factory Set* and click Load. To save a current camera configuration, select User Set 1 to 16 and click Save. Select a saved user set and click Load to restore a saved configuration.

Camera Control Category

The camera control category, as shown by CamExpert, groups control parameters such as line rate, exposure time, scan direction, and gain.

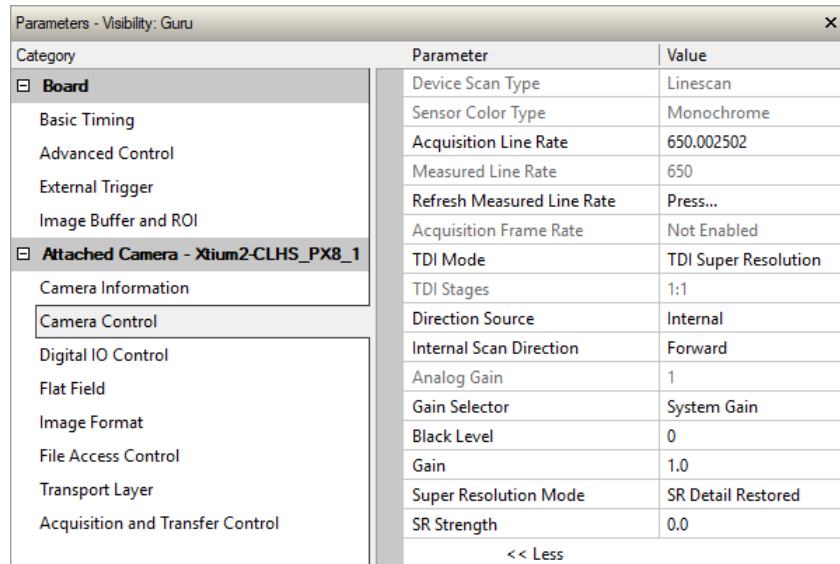

Figure 21: Camera Control Panel

Camera Control Feature Descriptions

Display Name	Feature	Description	View
Device Scan Type <i>Linescan</i>	DeviceScanType <i>Linescan</i>	Used to set the camera scanning mode. Only standard line scan mode is available. <i>Linescan sensor.</i>	Beginner
Sensor Color Type <i>Monochrome</i>	sensorColorType <i>Monochrome</i>	Used to set the sensor color type mode. Only monochrome is available. <i>Monochrome sensor.</i>	Beginner DFNC
Acquisition Line Rate	AcquisitionLineRate	Specifies the camera internal line rate, in Hz when Trigger mode set to internal. Note that any user entered value is automatically adjusted to a valid camera value. If necessary, the exposure time will be decreased to fit within the line time.	Beginner
Measured Line Rate	measureLineRate	Specifies the line rate provided to the camera by either internal or external source (RO)	Beginner DFNC
Refresh Measured Line Rate	refreshMeasureLineRate	Press to show the current line rate provided to the camera by either internal or external sources	Beginner DFNC
Acquisition Frame Rate	AcquisitionFrameRate	Displays the camera frame rate, in Hx.	Beginner
TDI Mode <i>TDI</i>	sensorTDIModeSelection <i>Tdi</i>	Select the TDI mode for the sensor. <i>Output one row from the main TDI array</i>	Beginner DFNC

Display Name	Feature	Description	View
<i>TDI Super Resolution</i>	<i>TdiMTF</i>	Combine the output from two arrays offset by ½ pixel.	
<i>TDI Planar</i>	<i>TdiTopTwoPlanar</i>	Output two rows, one from each of the main and secondary array with the responsivity ratio selectable	
<i>TDI Area</i>	<i>TdiArea</i>	Output the entire 128 row main array with an FVAL.	
<i>TDI Extended Area</i>	<i>TdiMultiArea</i>	TDI multiple array area mode for aligning camera.	
TDI Stages	sensorTDIStagesSelection	Selects the number of rows to integrate (sum/average) in TDI.	Beginner DFNC
<i>1:1</i>	<i>Ratio1</i>	<i>Single line</i> <i>(available when TDI Mode is TDI Super Resolution).</i>	
<i>2:1</i>	<i>Ratio05</i>	<i>Line 2 = 0.5 * Line 1</i> <i>(available when TDI Mode is TDI Super Resolution)</i>	
<i>4:1</i>	<i>Ratio025</i>	<i>Line 2 = 0.25 * Line 1</i> <i>(available when TDI Mode is TDI Super Resolution)</i>	
<i>8:1</i>	<i>Ratio0125</i>	<i>Three lines summed/averaged together.</i> <i>(available when TDI Mode is TDI Super Resolution)</i>	
<i>128</i>	<i>Lines128</i>	<i>128 lines summed/averaged together.</i> <i>(available when TDI Mode is TDI)</i>	
Direction Source	sensorScanDirectionSource	Direction determined by value of:	Beginner DFNC
<i>Internal</i>	<i>Internal</i>	<i>SensorScanDirection</i>	
<i>Line 2</i>	<i>GPIO2</i>	<i>Pin 6 (Low: forward, high: reverse). Available when TriggerSource is not Encoder.</i>	
<i>RotaryEncoder</i>	<i>Encoder</i>	<i>Rotary encoded. Available when TriggerSource is Encoder and rotaryEncoderOutputMode is Motion (see Digital IO Control category).</i>	
Internal Scan Direction	sensorScanDirection	When <i>ScanDirectionSource</i> is set to Internal, determines the direction of the scan	Beginner DFNC
<i>Forward</i>	<i>Forward</i>	<i>Forward scan direction.</i>	
<i>Reverse</i>	<i>Reverse</i>	<i>Reverse scan direction.</i>	
Gain Selector	GainSelector	Selects which gain is controlled when adjusting gain.	Beginner
<i>All Rows</i>	<i>All</i>	<i>Gain and offset applied to all channels.</i>	
<i>System Gain</i>	<i>System</i>	<i>System gain will apply the gain value while maintaining the existing gain ratios.</i>	
Black Level	BlackLevel	Controls the black level as an absolute physical value. This represents a DC offset applied to the video signal, in DN (digital number) units. The value may be positive or negative.	
Gain	Gain	Sets the gain as per the gain selector setting.	
Super Resolution Mode	sensorLineSpatialCorrection	Sets the number of rows each color is delayed to establish spatial alignment. Must stop acquisition to change.	Beginner DFNC
Super Resolution Mode	superResolutionMode	Sets the super resolution mode.	Beginner DFNC
<i>SR Mapped</i>	<i>srMapped</i>	<i>Super Resolution Mapped.</i>	
<i>SR Detail Restored</i>	<i>srDetailRestored</i>	<i>Super Resolution Detail Restored.</i>	
SR Strength	srStrength	Super resolution strength. Values range from 0 to 1, in increments of 0.01.	Beginner DFNC

Digital I / O Control Feature Descriptions

The camera's Digital I / O Control category is used to configure the cameras GPIO pins.

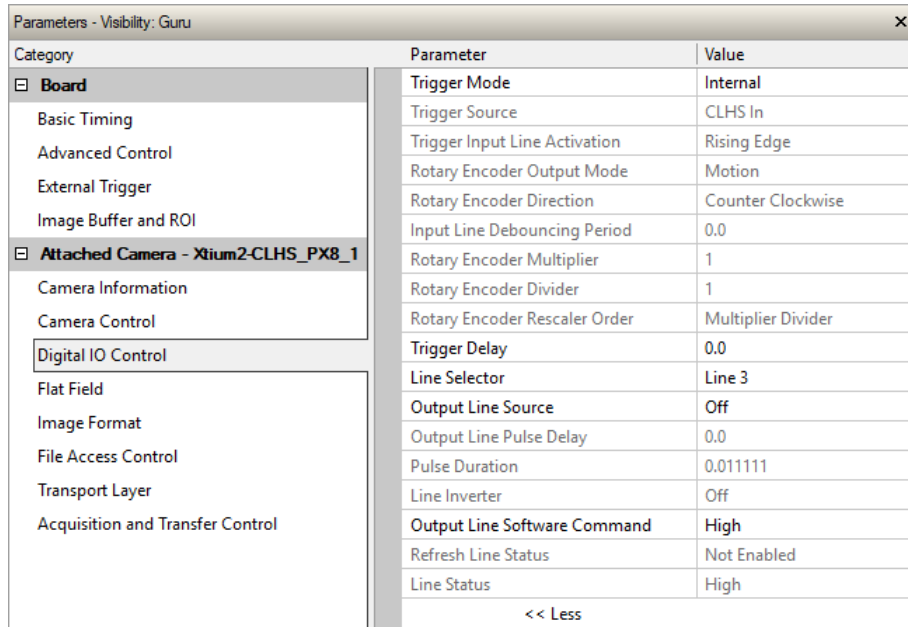

Figure 22 Digital I/O Control Panel

Digital I/O Control Feature Descriptions

Display Name	Feature	Description	View
Trigger Mode	TriggerMode	Determines the source of trigger to the camera.	Beginner
<i>Internal</i>	<i>Internal</i>	<i>Line rate is controlled with AcquisitionLineRate feature.</i>	
<i>External</i>	<i>External</i>	<i>Trigger comes from CLHS (frame grabber) or GPIO.</i>	
Trigger Source	TriggerSource	Determines the source of external trigger.	Beginner
<i>CLHS In</i>	<i>CLHS</i>	<i>Source of trigger is from the frame grabber over CLHS.</i>	
<i>Rotary Encoder</i>	<i>Encoder</i>	<i>Trigger source is from the two shaft encoder inputs.</i>	
<i>Line 1</i>	<i>GPIO1</i>	<i>Trigger source is from Line 1 of the GPIO connector.</i>	
Trigger Input Line ActivationEdge	TriggerActivation	Determines which edge of a input trigger will activate on	Beginner
<i>Rising Edge</i>	<i>RisingEdge</i>	<i>The trigger is considered valid on the rising edge of the line source signal (after any processing by the line inverter module).</i>	
<i>Falling Edge</i>	<i>FallingEdge</i>	<i>The trigger is considered valid on the falling edge.</i>	
<i>Any Edge</i>	<i>AnyEdge</i>	<i>The trigger is considered valid on any edge.</i>	
Rotary Encoder Direction	rotaryEncoderDirection	Specifies the phase which defines the encoder forward direction.	Beginner DFNC
<i>Counter Clockwise</i>	<i>CounterClockwise</i>	<i>Inspection goes forward when the rotary encoder direction is counter clockwise (phase A is ahead of phase B).</i>	
<i>Clockwise</i>	<i>Clockwise</i>	<i>Inspection goes forward when the rotary encoder direction is clockwise (phase B is ahead of phase A).</i>	

Display Name	Feature	Description	View
Rotary Encoder Output Mode	rotaryEncoderOutputMode	Specifies the conditions for the Rotary Encoder interface to generate a valid Encoder output signal.	Beginner DFNC
	<i>Position</i>	<i>Position</i> Triggers are generated at all new position increments in the selected direction. If the encoder reverses no trigger events are generated until it has again passed the position where the reversal started.	
	<i>Motion</i>	<i>Motion</i> The triggers are generated for all motion increments in either direction.	
Input Line Debouncing Period	lineDebouncingPeriod	Specifies the minimum delay before an input line voltage transition is recognizing as a signal transition.	Beginner DFNC
Rotary Encoder Multiplier	rotaryEncoderMultiplier	Specifies a multiplication factor for the rotary encoder output pulse generator.	Beginner
Rotary Encoder Divisor	rotaryEncoderDivider	Specifies a division factor for the rotary encoder output pulse generator.	Beginner DFNC
Rotary Encoder Rescaler Order	rotaryEncoderRescalerOrder	Specifies the order that the multiplier and divider are applied.	Beginner DFNC
	<i>Multiplier Divider</i>	<i>multiplierDivider</i> The signal is multiplied before been divided.	
	<i>Divider Multiplier</i>	<i>dividerMultiplier</i> The signal is divided before been multiplied	
Trigger Delay	TriggerDelay	Allows the trigger to the sensor to be delayed relative to camera input trigger	Beginner
Line Selector	LineSelector	Selects the physical line (or pin) of the external device connector to configure.	Beginner
	<i>Line 1</i>	<i>GPIO1</i> Index of the physical line and associated I/O control block to use.	
	<i>Line 2</i>	<i>GPIO2</i>	
	<i>Line 3</i>	<i>GPIO3</i>	
	<i>Line 4</i>	<i>GPIO4</i>	
	<i>Line 5</i>	<i>GPIO5</i>	
	<i>Line 6</i>	<i>GPIO6</i>	
Output Line Source	outputLineSource	Selects which features control the output on the selected line.	Beginner DFNC
	<i>Off</i>	<i>Off</i> Line output level is controlled by the outputLineSoftwareCmd feature.	
	<i>On</i>	<i>On</i> Line output level is controlled by outputLinePulseDelay, outputLinePulseDuration, and LineInverter features.	
Output Line Pulse Delay	outputLinePulseDelay	Sets the delay (in μ s) before the output line pulse signal. Enabled by the OutputLineSource feature.	Beginner DFNC
Pulse Duration	outputLinePulseDuration	Sets the width (duration) of the output line pulse in microseconds.	Beginner DFNC
Line Inverter	LineInverter	Controls whether to invert the polarity of the selected input or output line signal.	Beginner
	<i>Off</i>	<i>Off</i> The line signal is not inverted.	
	<i>On</i>	<i>On</i> The line signal is inverted.	
Output Line Software Command	outputLineSoftwareCmd	Set the GPIO out value when outputLineSource is off.	Expert DFNC
Refresh Line Status	refreshLineStatus	Update the LineStatus feature	Beginner DFNC
Line Status	LineStatus	Returns the current state of the GPIO line selected with the LineSelector feature. (RO)	Expert

Flat Field Category

The Flat Field controls, as shown by CamExpert, group parameters used to control the FPN and PRNU calibration process.

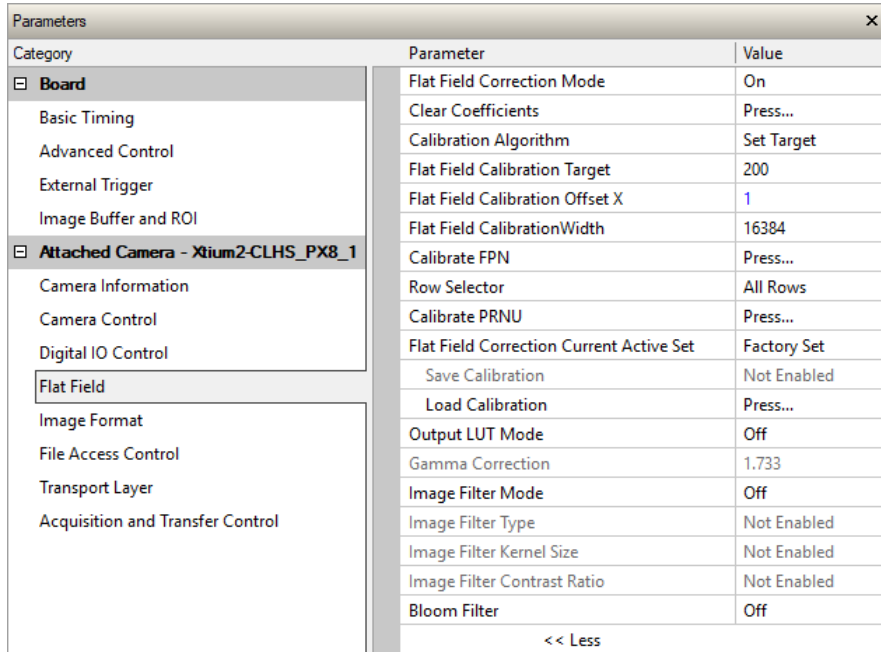

Figure 23: Flat Field Panel

Flat Field Control Feature Description

Display Name	Feature	Description	View
Flat Field Correction Mode	flatfieldCorrectionMode		Beginner DFNC
	<i>Off</i>	<i>Off</i> FPN and PRNU correction disabled.	
	<i>On</i>	<i>On</i> FPN and PRNU correction enabled.	
Clear Coefficients	flatfieldCalibrationClearCoefficient	Reset all FPN to 0 and all PRNU coefficients to 1.	Beginner DFNC
Calibration Algorithm	flatfieldCorrectionAlgorithm	Selection between four different PRNU algorithms.	Beginner DFNC
	<i>Peak</i>	<i>Peak</i> Calculation of PRNU coefficients to bring all pixels to the peak.	
	<i>Peak, Image Filtered</i>	<i>PeakFilter</i> A low pass filter is applied to the average line values before calculating the coefficients. Use this algorithm if the calibration target is not uniformly white or if it is not possible to defocus the image. Because of the low pass filter, this algorithm is not able to correct pixel-to-pixel variations and so it is preferable to use the "Peak" algorithm.	

Display Name	Feature	Description	View
<i>Set Target</i>	<i>Target</i>	<i>Calculation of PRNU coefficients to bring all pixels to the target value.</i>	
<i>Set Target, Image Filtered</i>	<i>TargetFiltered</i>	<i>A low pass filter is applied to the average line values before calculating the coefficients. Use this algorithm if the calibration target is not uniformly white or if it is not possible to defocus the image. Because of the low pass filter this algorithm is not able to correct pixel-to-pixel variations and so it is preferable to use the "Target" algorithm.</i>	
Flat Field Calibration Target	flatfieldCalibrationTarget	Sets the target value for the "Calibrate PRNU" feature.	Beginner DFNC
Flat Field Calibration Offset X	flatfieldCalibrationROIOffsetX	Set the starting point of a region of interest where a flat field calibration will be performed	Beginner DFNC
Flat Field Calibration Width	flatfieldCalibrationROIWidth	Sets the width of the region of interest where a flat field calibration will be performed	Beginner DFNC
Calibrate FPN	flatfieldCalibrationFPN	Initiates the FPN calibration process	Beginner DFNC
Row Selector	flatfieldCalibrationColorSelector	Specify which sensor rows to perform PRNU calibration on, all or individual colors.	Beginner DFNC
Calibrate PRNU	flatfieldCalibrationPRNU	Initiates the PRNU calibration process	Beginner DFNC
Flat Field Correction Current Active Set	flatfieldCorrectionCurrentActiveSet	Selects the User PRNU set to be saved or loaded.	Guru DFNC
<i>Factory Set</i>	<i>Factory Set</i>	<i>Factory set can only be loaded.</i>	
<i>User Set 1 (1 thru 16)</i>	<i>UserSet1 (1 thru 16)</i>	<i>Only the PRNU values are saved or loaded which is much faster than saving or loading the full Factory or User set.</i>	
Save Calibration	flatfieldCalibrationSave	Saves the User PRNU set specified by flatfieldCorrectionCurrentActiveSet to the camera.	Guru DFNC
Load Calibration	flatfieldCalibrationLoad	Loads the User PRNU set specified by flatfieldCorrectionCurrentActiveSet to the camera and makes it active.	Guru DFNC
Output LUT Mode	lutMode	Allows the output LUT to be selected When enabled, the same LUT is used for all colors	Beginner DFNC
<i>Off</i>	<i>Off</i>	<i>The output LUT is disabled and linear data is output</i>	
<i>Gamma Correction</i>	<i>Gamma</i>	<i>LUT populated using the Gamma correction equation</i>	
<i>User Defined</i>	<i>UserDefined</i>	<i>LUT uploaded by the user is used.</i>	
Gamma Correction	gammaCorrection	The output LUT is populated using the following gamma correction equation: $DN_{out} = 255 \times \left(\frac{DN_{in}}{255}\right)^{\frac{1}{\gamma}}$	Beginner DFNC

Display Name	Feature	Description	View
Image Filter Mode	imageFilterMode	Enable image filter.	Guru DFNC
	<i>Off</i>	<i>Off</i> Disable the image filter.	
	<i>Active</i>	<i>Active</i> Enable the image filter	
Image Filter Type	imageFilterType	Specifies the image filter type. Read-only.	Guru DFNC
	<i>Weighted Average</i>	<i>Weighted_Average</i> Wieght average algorithm.	
Image Filter Kernel Size	imageFilterKernelSize	Selects the kernel size.	Guru DFNC
	<i>Kernel 1x3</i>	<i>KERNEL_1x3</i> 1x3 kernel.	
	<i>Kernel 1x5</i>	<i>KERNEL_1x5</i> 1x5 kernel.	
Image Filter Contrast Ratio	imageFilterContrastRatio	Sets the image filter contrast ratio threshold. Values range from 0 to 1.	Guru DFNC
Bloom Filter		Sets the enable state of the anti-blooming filter.	Guru DFNC
	<i>Off</i>	<i>Off</i> Disable the anti-blooming filter.	
	<i>Active</i>	<i>Active</i> Enable the anti-blooming filter	

Image Format Control Category

The camera's Image Format controls, as shown by CamExpert, group parameters used to configure camera pixel format, image cropping, binning and test pattern generation features.

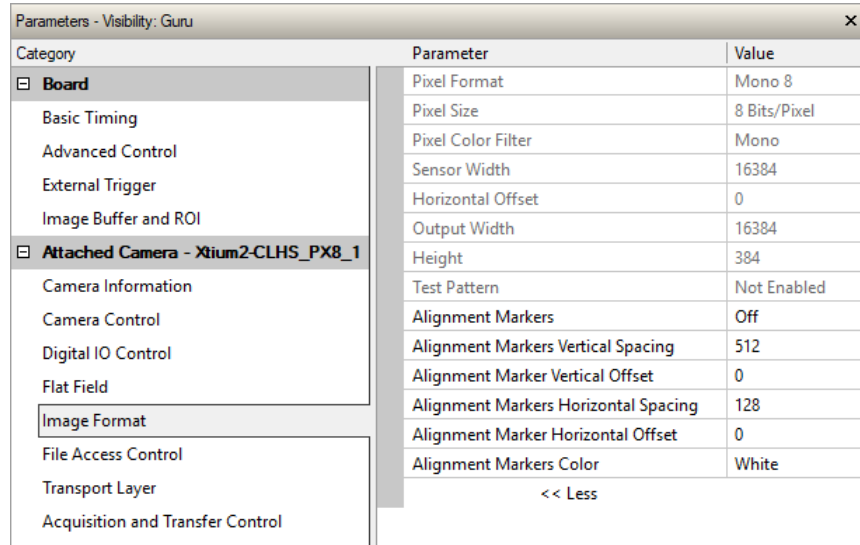

Figure 24: Image Format Panel

Image Format Control Feature Description

Display Name	Feature	Description	View
Pixel Format <i>Mono 8</i>	PixelFormatr <i>Mono8</i>	Output image pixel coding format of the sensor. <i>8-bit monochrome format is used when processing each color separately.</i>	Beginner
Pixel Size <i>8 Bits/Pixel</i>	PixelSize <i>Bpp8</i>	Total size in bits of an image pixel. Read-only. <i>8 Bits / Pixel.</i>	Guru
Pixel Coding Filter <i>None</i>	PixelCodingFilter <i>Mono</i>	Indicates the type of color filter used in the camera. Read only. <i>No pixel coding filter when pixel format is Mono 8.</i>	Beginner DFNC
Horizontal Offset	OffsetX	Output image horizontal offset from the origin. This is zero for color cameras. Read only	Beginner
Output Width	Width	Horizontal width of the pixels output. Read only	Beginner
Height	Height	Height of the image provided by the device (in object pixels). 1 to 3. Read only.	Beginner
Test Pattern <i>Off</i> <i>Each Tap Fixed</i> <i>Grey Horizontal Ramp</i>	TestImageSelector <i>Off</i> <i>EachTapFixed</i> <i>Grey Horizontal Ramp</i>	Selects the type of test image that is sent by the camera. Note. Grey images are displayed so that any bit error will immediately be apparent as a color. <i>Selects sensor video to be output</i> <i>Selects a grey scale value that is increased every 512 pixels.</i> <i>Selects a grey scale ramp</i>	Beginner

<i>Grey Vertical Ramp</i>	<i>Grey Vertical Ramp</i>	<i>Selects a grey scale ramp progressively for each row.</i>	
<i>Grey Diagonal Ramp</i>	<i>Grey Diagonal Ramp</i>	<i>Selects a combination of horizontal and vertical ramps to form a diagonal grey scale.</i>	
<i>User Pattern</i>	<i>User Pattern</i>	<i>User can define a test pattern by uploading to the camera a PRNU file using the FileAccess > Miscellaneous > User PRNU feature. The PRNU coefficient will be applied to a midscale (128 DN) test image. Contact Teledyne DALSA support for an Excel file that can help with this.</i>	
Alignment Markers	alignmentMarkerEnable	To assist with camera alignment, alignment markers can be enabled in the output.	Beginner DFNC
<i>Off</i>	<i>Off</i>	<i>Disable alignment markers</i>	
<i>Vertical On</i>	<i>Vertical</i>	<i>Enable Vertical Alignment Markers only</i>	
<i>Horizontal On</i>	<i>Horizontal</i>	<i>Enable Horizontal Alignment Markers only</i>	
<i>Both On</i>	<i>Both</i>	<i>Enable Vertical and Horizontal Alignment Markers</i>	
Alignment Marker Vertical Spacing	alignmentMarkerVerticalSpacing	Vertical spacing between alignment markers, in pixels.	Beginner DFNC
<i>64</i>	<i>Ver64</i>	<i>64 pixels between vertical alignment markers</i>	
<i>128</i>	<i>Ver128</i>	<i>128 pixels between vertical alignment markers</i>	
<i>256</i>	<i>Ver256</i>	<i>256 pixels between vertical alignment markers</i>	
<i>512</i>	<i>Ver512</i>	<i>512 pixels between vertical alignment markers</i>	
Alignment Marker Vertical Offset	alignmentMarkerVerticalOffset	Pixel count before first vertical alignment marker. Integer between 0 and <i>alignmentMarkerVerticalSpacing</i> value.	Beginner DFNC
Alignment Marker Horizontal Spacing	alignmentMarkerHorizontalSpacing	Horizontal spacing between alignment markers, in pixels.	Beginner DFNC
<i>16</i>	<i>Hor16</i>	<i>16 pixels between horizontal alignment markers</i>	
<i>32</i>	<i>Hor32</i>	<i>32 pixels between horizontal alignment markers</i>	
<i>64</i>	<i>Hor64</i>	<i>64 pixels between horizontal alignment markers</i>	
<i>128</i>	<i>Hor128</i>	<i>128 pixels between horizontal alignment markers</i>	
Alignment Marker Horizontal Offset	alignmentMarkerHorizontalOffset	Pixel count before first horizontal alignment marker. Integer between 0 and <i>alignmentMarkerHorizontalSpacing</i> value.	Beginner DFNC
Alignment Markers Color	alignmentMarkerBlack	Specifies the alignment marker color.	Beginner DFNC
<i>White</i>	<i>White</i>	<i>White alignment markers.</i>	
<i>Black</i>	<i>Black</i>	<i>Black alignment markers.</i>	
Input Pixel Size	pixelSizeInput	Size of the image input pixels, in bits per pixel. (RO)	DFNC Invisible
<i>12 Bits/Pixel</i>	<i>Bpp12</i>	<i>Sensor input data path is 12 bits per pixel.</i>	

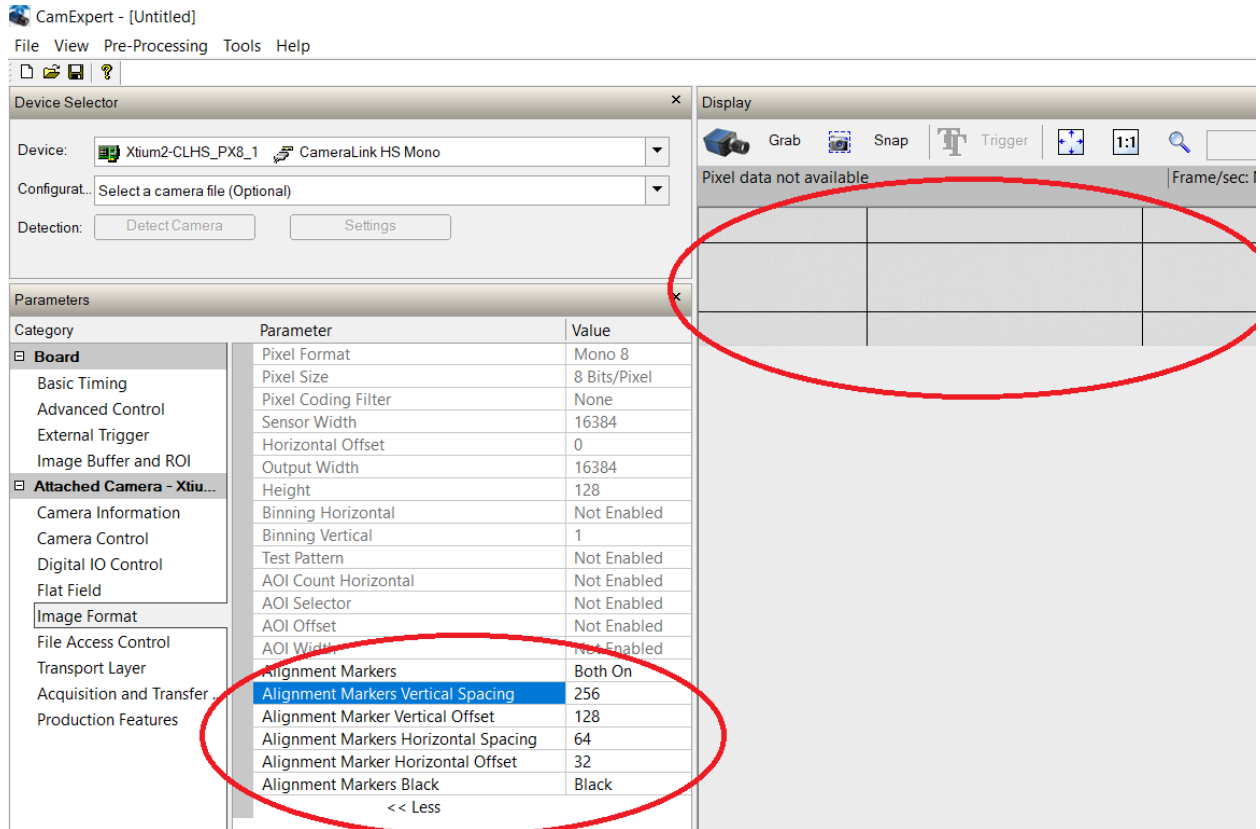



Figure 25: Alignment Markers

Use alignment markers to assist in aligning the camera. Alignment markers can be enabled in the output.

File Access Control Category

The File Access control in CamExpert allows the user to quickly upload and download of various data files to/from the connected the camera. The supported data files for the camera include firmware updates and Flat Field coefficients.

 **Note:** The communication performance when reading and writing large files can be improved by stopping image acquisition during the transfer

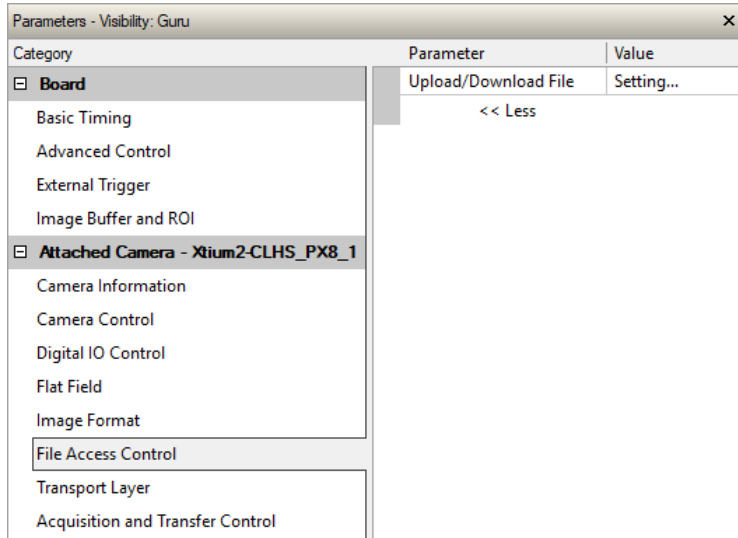

Figure 26: File Access Control Panel

File Access Control Feature Descriptions

Display Name	Feature	Description	View
File Selector	FileSelector	Selects the file to access. The files which are accessible are listed in the XML:	Beginner
All Firmware	Firmware1	Upload micro code, FPGA code & XML as a single file to the camera which will execute on the next camera reboot cycle.	
User Set	User_Set	Use UserSetSelector to specify which user set to access.	
Output LUT	Output_LUT	Use UserSetSelector to specify which LUT to access.	
User PRNU	User_PRNU	Use UserSetSelector to specify which user PRNU to access.	
User FPN	User_FPN	Use UserSetSelector to specify which user FPN to access.	
Current PRNU	Cur_PRNU	Accesses the PRNU coefficients that are currently being used by the camera (not necessarily saved).	
Camera_Data	CameraData	Download camera information and send for customer support.	
File Operation Selector	FileOperationSelector	Selects the operation for the selected file in the device. This operation is executed when the File Operation Execute feature is called.	Guru
Open	Open	Select the Open operation - executed by FileOperationExecute.	
Close	Close	Select the Close operation - executed by FileOperationExecute.	
Read	Read	Select the Read operation - executed by FileOperationExecute.	
Write	Write	Select the Write operation - executed by FileOperationExecute.	

Display Name	Feature	Description	View
File Operation Execute	FileOperationExecute	Executes the operation selected by File Operation Selector on the selected file.	Guru
File Open Mode	FileOpenMode	Selects the access mode used to open a file on the device. <i>Read</i> Select <i>READ</i> only open mode <i>Write</i> Select <i>WRITE</i> only open mode	Guru
File Access Buffer	FileAccessBuffer	Defines the intermediate access buffer that allows the exchange of data between the device file storage and the application.	Guru
File Access Offset	FileAccessOffset	Controls the mapping offset between the device file storage and the file access buffer.	Guru
File Access Length	FileAccessLength	Controls the mapping length between the device file storage and the file access buffer.	Guru
File Operation Status	FileOperationStatus	Displays the file operation execution status. (RO).	Guru
Success	Success	The last file operation has completed successfully.	
Invalid Parameter	InvalidParameter	An invalid parameter was passed to the last feature called.	
Write Protect	WriteProtect	Attempt to write to a read-only (factory) file.	
File Not Open	FileNotOpen	The file has not been opened yet.	
File Too Big	FileTooBig	The file is larger than expected.	
File Invalid	FileInvalid	The last file operation has completed unsuccessfully because the selected file is not present in this camera.	
File Operation Result	FileOperationResult	For Read or Write operations, the number of successfully read/written bytes is returned. (RO)	Guru
File Size	FileSize	Represents the size of the selected file in bytes.	Guru

File Access via the CamExpert Tool

1. Click on the "Setting..." button to show the File Access Control dialog box.



Figure 27: File Access Control Tool

2. From the Type drop menu, select the file type that will be uploaded to the camera or downloaded from the camera.
3. From the File Selector drop menu, select the file to be uploaded or downloaded.
4. To upload a file, click the Browse button to open a typical Windows Explorer window.
 - a. Select the specific file from the system drive or from a network location.
 - b. Click the Upload button to execute the file transfer to the camera.
5. Alternatively, click the Download button and then specify the location where the file should be stored.
6. Note that firmware changes require that the camera be powered down and then back up. Additionally, CamExpert should be shut down and restarted following a reset.
7. Caution: Do not interrupt the file transfer by powering down the camera or closing CamExpert.

CLHS File Transfer Protocol

If you are not using CamExpert to perform file transfers, pseudo-code for the CLHS File Transfer Protocol is as follows.

Download File from Camera

- Select the file by setting the FileSelector feature
- Set the FileOpenMode to Read
- Set the FileOperationSelector to Open
- Open the file by setting FileOperationExecute to 1
This is a read-write feature - poll it every 100 ms until it returns 0 to indicate it has completed
- Read FileOperationStatus to confirm that the file opened correctly
 - A return value of 0 is success. Error codes are listed in the XML.
- Read FileSize to get the number of bytes in the file
- From FileAccessBuffer.Length you will know that maximum number of bytes that can be read through FileAccessBuffer is 988.
- For Offset = 0 While ((Offset < FileSize) and (Status = 0)) Do
 - Set FileAccessOffset to Offset
 - Set FileAccessLength to min(FileSize - Offset, FileAccessBuffer.Length), the number of bytes to read
 - Set the FileOperationSelector to Read
 - Read the file by setting FileOperationExecute to 1 and poll until 0 and complete
 - Read FileOperationStatus to confirm the read worked
 - Read FileOperationResult to confirm the number of bytes read
 - Read the bytes from FileAccessBuffer
 - Write bytes read to host file.
- Next Offset = Offset + number of bytes read
- Set the FileOperationSelector to Close
- Close the file by setting FileOperationExecute to 1 and poll until 0 and complete
- Read FileOperationStatus to confirm the close worked

Upload File to Camera

- Select the file by setting the FileSelector feature
- Set the FileOpenMode to Write
- Set the FileOperationSelector to Open
- Open the file by setting FileOperationExecute to 1
This is a read-write feature - poll it every 100 ms until it returns 0 to indicate it has completed
- Read FileOperationStatus to confirm that the file opened correctly
A return value of 0 is success. Error codes are listed in the XML.
- Read FileSize to get the maximum number of bytes allowed in the file
 - Abort and jump to Close if this is less the file size on the host
- From FileAccessBuffer.Length you will know that maximum number of bytes that can be written through FileAccessBuffer is 988.
- For Offset = 0 While ((Offset < Host File Size) and (Status = 0)) Do
 - Set FileAccessOffset to Offset
 - Set FileAccessLength to min(Host File Size - Offset, FileAccessBuffer.Length), the number of bytes to write
 - Read next FileAccessLength bytes from host file.
 - Write the bytes to FileAccessBuffer
 - Set the FileOperationSelector to Write
 - Write to the file by setting FileOperationExecute to 1 and poll until 0 and complete
 - Read FileOperationStatus to confirm the write worked
 - Read FileOperationResult to confirm the number of bytes written
- Next Offset = Offset + number of bytes written
- Set the FileOperationSelector to Close
- Close the file by setting FileOperationExecute to 1 and poll until 0 and complete
- Read FileOperationStatus to confirm the close worked

Download a List of Camera Parameters

For diagnostic purposes you may want to download a list of all the parameters and values associated with the camera.

1. Go to File Access Control
2. Click on Settings
3. In the "Type" drop down box select "Miscellaneous."
4. In the "File selector" drop down box select "CameraData."
5. Hit "Download"
6. Save the text file and send the file to Teledyne DALSA customer support.

Transport Layer Control Category

The Transport Layer Control category, as shown by CamExpert, has parameters used to configure features related to GigE Vision specification and the Ethernet Connection.

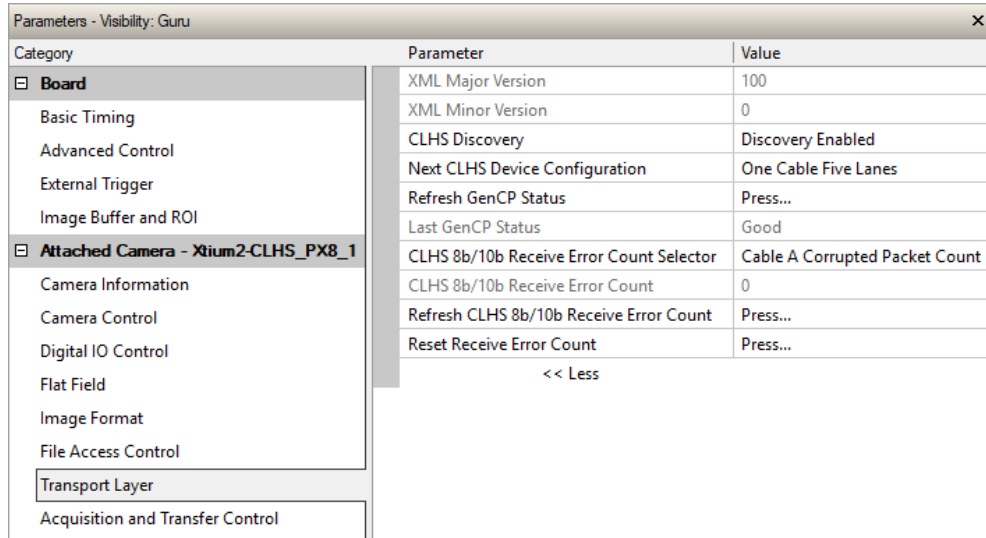

Figure 28: Transport Layer Panel

Transport Layer Feature Descriptions

Display Name	Feature	Description	View
XML Major Version	DeviceManifestXMLMajorVersion	Together with DeviceManifestXMLMinorVersion specifies the GenICam™ feature description XML file version (RO)	Beginner
XML Minor Version	DeviceManifestXMLMinorVersion	Together with DeviceManifestXMLMajorVersion specifies the GenICam™ feature description XML file version (RO)	Beginner
Next CLHS Device Configuration <i>One Cable Five Lanes</i>	clhsNextDeviceConfig <i>OneCableFiveLanes</i>	When the camera is next powered up, the specified CLHS lane configuration will be set for the camera. <i>CX4 configuration</i>	Guru DFNC
Refresh GenCP Status	refreshGenCPStatus	Press to update the GenCP Status.	Beginner DFNC
Last GenCP Status	genCPStatus	If a feature read or write returns that it fails, read this feature to get the actual reason for the failure Returns the last error. Reading this feature clears it. Sopera only.	Beginner DFNC
CLHS 8b/10b Receive Error Count Selector	clhsErrorCountSelector	Select the error to count	Guru DFNC
<i>Cable A Corrupted Packet Count</i>	<i>CorruptedPacketCntA</i>	<i>Count of corrupted packets on cable A.</i>	
<i>Cable A Corrected Packet Count</i>	<i>CorrectedPacketCntA</i>	<i>Count of corrected packets on cable A.</i>	
<i>Cable B Corrupted Packet Count</i>	<i>CorruptedPacketCntB</i>	<i>Count of corrupted packets on cable B.</i>	
<i>Cable B Corrected Packet Count</i>	<i>CorrectedPacketCntB</i>	<i>Count of corrected packets on cable B.</i>	

CLHS 8b/10b Receive Error Count	<code>clhsErrorCount</code>	CLHS 8b/10b Receive Error Count	Guru DFNC
Refresh CLHS 8b/10b Receive Error Count	<code>clhsErrorCountRefresh</code>	Refresh the selected <i>clhsErrorCount</i> value.	Guru DFNC
Reset Receive Error Count	<code>clhsErrorCountReset</code>	Reset the selected <i>clhsErrorCount</i> value to 0.	Guru DFNC

Acquisition and Transfer Control Category

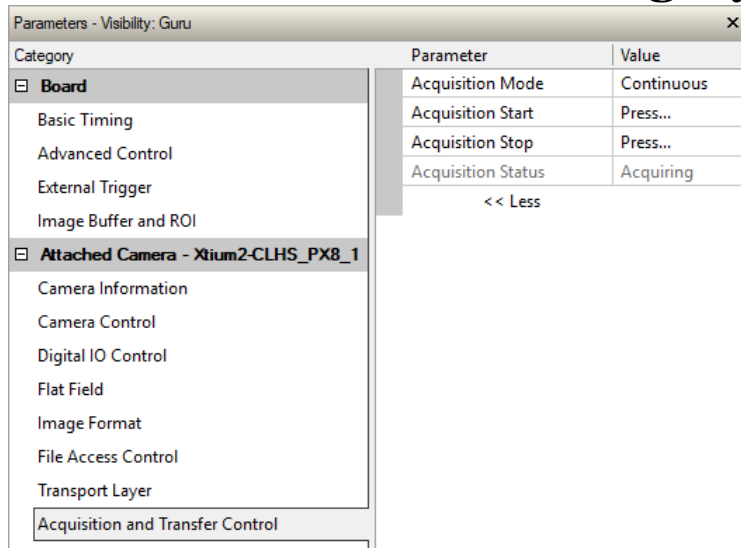

Figure 29: Acquisition & Transfer Control Panel

Acquisition and Transfer Control Feature Descriptions

Display Name	Feature	Description	View
Acquisition Mode	AcquisitionMode	The device acquisition mode defines the number of frames to capture during an acquisition and the way it stops	Beginner
<i>Continuous</i>	<i>Continuous</i>	<i>Only continuous mode is currently available.</i>	
Acquisition Start	AcquisitionStart	Commands the camera to start sending image data. (WO)	Beginner
Acquisition Stop	AcquisitionStop	Commands the camera to stop sending image data at the end of the current line (WO)	Beginner
Acquisition Status	AcquisitionStatus	Indicates whether the camera has been commanded to stop or to send image data.	Beginner

Appendix B: Trouble Shooting Guide

Diagnostic Tools

Camera Data File

The camera data file includes the operational configuration and status of the camera. This text file can be downloaded from the camera and forwarded to Teledyne DALSA Technical Customer support team to aid in diagnosis of any reported issues. See Saving & Restoring Camera Setup Configurations of the user manual for details on downloading the Camera Data file.

Voltage & Temperature Measurement

The camera can measure the input supply voltage at the power connector and the internal temperature. Both of these features are accessed using the Camera CamExpertGUI > Camera Information tab. Press the associated refresh button for a real-time measurement.

Test Patterns – What Can They Indicate?

The camera can generate fixed test patterns that may be used to determine the integrity of the CLHS communications beyond the Lock status. The test patterns give the user the ability to detect bit errors using an appropriate host application. This error detection would be difficult, if not impossible, using normal image data.



Note: Gray images are displayed so that any bit error will immediately be apparent as colored pixels in the image.

There are five test patterns that can be selected via the Cameras CamExpertGUI > Image Format tab. They have the following format when using 8-bit data:

- Each Tap Fixed
 - Starting at 64 increases in by 4 steps every 512 pixels ending in 188.
- Grey Horizontal Ramp
 - 2 horizontal ramps starting at 00H increases in by 01H every 32 pixels.
- Grey Vertical Ramp
 - Vertical ramp starting with 1st row 5, next row 12, and incrementing by 3 every line
- Grey Diagonal Ramp
 - Add horizontal and vertical ramps
- User Pattern
 - When selected, the camera will first output all pixels values to be half full scale. The user can then generate a custom test pattern by uploading PRNU coefficients that appropriately manipulate the half scale data to achieve the desired pattern. See section Setting Custom Flat Field Coefficients for details.

Built-In Self-Test Codes

The Built-In Self-test (BIST) codes are located in the Camera Information pane under Power-on Status. None of these should occur in a properly functioning camera except OVER_TEMPERATURE. OVER_TEMPERATURE occurs if the ambient temperature is too high, there is insufficient air circulation or heat sinking.

Table 17: BIST Codes

Bit Number	Name	Hex Position	Binary Translation
1	I2C	0x00000001	0000 0000 0000 0000 0000 0000 0000 0001
2	FPGA_NO_INIT	0x00000002	0000 0000 0000 0000 0000 0000 0000 0010
3	FPGA_NO_DONE	0x00000004	0000 0000 0000 0000 0000 0000 0000 0100
4	SENSOR_SPI	0x00000008	0000 0000 0000 0000 0000 0000 0000 1000
5	ECHO_BACK	0x00000010	0000 0000 0000 0000 0000 0000 0001 0000
6	FLASH_TIMEOUT	0x00000020	0000 0000 0000 0000 0000 0000 0010 0000
7	FLASH_ERROR	0x00000040	0000 0000 0000 0000 0000 0000 0100 0000
8	NO_FPGA_CODE	0x00000080	0000 0000 0000 0000 0000 0000 1000 0000
9	NO_COMMON_SETTINGS	0x00000100	0000 0000 0000 0000 0000 0001 0000 0000
10	NO_FACTORY_SETTINGS	0x00000200	0000 0000 0000 0000 0000 0010 0000 0000
11	OVER_TEMPERATURE	0x00000400	0000 0000 0000 0000 0000 0100 0000 0000
12	SENSOR_PATTERN	0x00000800	0000 0000 0000 0000 0000 1000 0000 0000
13	NO_USER_FPN	0x00001000	0000 0000 0000 0000 0001 0000 0000 0000
14	NO_USER_PRNU	0x00002000	0000 0000 0000 0000 0010 0000 0000 0000
15	CLHS_TXRDY_RETRY	0x00004000	0000 0000 0000 0000 0100 0000 0000 0000
16	(Reserved)	0x00008000	0000 0000 0000 0000 1000 0000 0000 0000
17	NO_USER_SETTINGS	0x00010000	0000 0000 0000 0001 0000 0000 0000 0000
18	NO_ADC_COEFFICIENTS	0x00020000	0000 0000 0000 0010 0000 0000 0000 0000
19	NO_SCRIPT	0x00040000	0000 0000 0000 0100 0000 0000 0000 0000
20	(Reserved)	0x00080000	0000 0000 0000 1000 0000 0000 0000 0000
21	(Reserved)	0x00100000	0000 0000 0001 0000 0000 0000 0000 0000
22	(Reserved)	0x00200000	0000 0000 0010 0000 0000 0000 0000 0000
23	NO_FACT_PRNU	0x00400000	0000 0000 0100 0000 0000 0000 0000 0000
24	NO_FATFS	0x00800000	0000 0000 1000 0000 0000 0000 0000 0000

Status LED

A single red / green LED is located on the back of the camera to indicate status.

Table 18: Status LED States

LED State	Description
Off	Camera not powered up or waiting for the software to start
Constant Red	The camera BIST status is not good. See BIST status for diagnosis.
Blinking Red	The camera has stopped output and has shut down some components due to an over temperature condition.
Blinking Orange	Powering Up. The microprocessor is loading code.
Blinking Green	Hardware is good, but the CLHS connection has not been established or has been broken.
Constant Green	The CLHS Link has been established and data transfer may begin

Resolving Camera Issues

Communications

No Camera Features when Starting CamExpert

If the camera's CamExpert GUI is opened and no features are listed, then the camera may be experiencing lane lock issues.

While using the frame grabber CamExpert GUI you should be able to see a row of status indicators below the image area that indicates the status of the CLHS communications. These indicators include seven lane lock status and a line valid (LVAL) status.

If the status for one or more lane locks is red, then there is likely an issue with the CLHS connectors at the camera and / or frame grabber. Ensure that the connectors are fully engaged and that the jack screws are tightened. Ensure that you are also using the recommended cables.

No LVAL

If the LVAL status is red and all lane locks are green, then there may be an issue with the camera receiving the encoder pulses.

1. From the Camera CamExpert > Digital I / O Control tab, select Internal Trigger Mode and set the CamExpert > Camera Control tab Acquisition Line Rate to the maximum that will be used.
2. The trigger signal from the frame grabber will not be used and the LVAL status should now be green. This will confirm the integrity of the image data portion of the CLHS cabling and connectors.
3. From the Camera CamExpert > Digital I / O Control tab, select External Trigger Mode.
4. From the Frame Grabber CamExpert > Advanced tab, select the Line Sync Source to be Internal Line Trigger and the Internal Line Trigger frequency to the maximum that will be used.
5. The trigger source is now being generated by the frame grabber and the LVAL status should be green. This will confirm the integrity of the General Purpose I / O portion of the CLHS cabling and connectors.
6. From the Frame Grabber CamExpert > Advanced tab, select the Line Sync Source to be External Line Trigger and select the Line Trigger Method to Method 2 under the same tab.
7. From the Frame Grabber CamExpert > External Trigger tab, select External Trigger to be enabled. If LVAL status turns red, check the following:
 - a. Is the transport system moving such that encoder pulses are being generated?
 - b. Has the encoder signal been connected to the correct pins of the I/O connector of the frame grabber? See the XTUM2-CLHS frame grabber user manual for details.
 - c. Do the encoder signal levels conform to the requirements outlined in the XTUM2-CLHS frame grabber user manual?

Image Quality Issues

Vertical Lines Appear in Image after Calibration

The purpose of flat field calibration is to compensate for the lens edge roll-off and imperfections in the illumination profiles by creating a uniform response. When performing a flat field calibration, the camera must be imaging a flat white target that is illuminated by the actual lighting used in the application. Though the camera compensates for illumination imperfection, it will also compensate for imperfections such as dust, scratches, paper grain, etc. in the white reference. Once the white reference is removed and the camera images the material to be inspected, any white reference imperfections will appear as vertical stripes in the image. If the white reference had imperfections that caused dark features, there will be a bright vertical line during normal imaging. Similarly, bright features will cause dark lines. It can be very difficult to achieve a perfectly uniform, defect-free white reference. The following two approaches can help in minimizing the effects of white reference defects:

1. Move the white reference closer to or further away from the object plane such that it is out of focus. This can be effective if the illumination profile changes minimally when relocating the white reference.
2. If the white reference must be located at the object plane, then move the white reference in the scan direction or sideways when flat field calibration is being performed. The camera averages several thousand lines when capturing calibration reference images so any small imperfections are averaged out.
3. Use the camera's flat field calibration filter feature, as detailed in the user manual Flat Field Calibration Filter section. This algorithm implements a low pass moving average that covers several adjacent pixels. This filter can help minimize the effects of minor imperfections in the white reference. Note: this filter is NOT USED in normal imaging.

Over Time, Pixels Developing Low Response

When flat field calibration is performed using a white reference, as per the guidelines in the user manual, all pixels should achieve the same response. However, over time dust in the lens extension tube may migrate to the sensor surface and reduce the response of some pixels.

If the dust particles are small, they may have only a minor effect on responsivity, but still create vertical dark lines that interfere with defect detection and that need to be corrected.

Because repeating the flat field calibration with a white reference may not be practical while the camera installed in the system, the camera has a feature where the flat field coefficients can be downloaded to the host PC and adjusted using a suitable application, such as Microsoft Excel. (See section Setting Custom Flat Field Coefficients for details.)

If the location of the pixel returning a low response can be identified from the image, then the correction coefficient of that pixel can be adjusted, saved as a new file, and then uploaded to the camera; thereby correcting the image without performing a flat field calibration.

See the user manual for details on downloading and uploading camera files using CamExpert.



Note: Dust accumulation on the lens will not cause vertical lines. However, a heavy accumulation of dust on the lens will eventually degrade the camera's responsivity and focus quality.

Smearred & Distorted Images

To achieve a well-defined image, the multiple lines are summed together and delayed in a manner that matches the motion of the image across the sensor.

This synchronization is achieved by sending an external synchronization (EXSYNC) signal to the camera, where one pulse is generated when the object moves by the size of one object pixel. See 'External Trigger Mode' in the user manual.

Any transport motion that is not correctly reflected in the EXSYNC pulses will cause image distortion in the scan direction. For standard line scan cameras, this type of image distortion may not greatly affect edge sharpness and small defect contrast; thereby having minimal impact on defect detection. However, TDI image quality is more sensitive to object motion synchronization errors.

The following subsections discuss causes of poor image quality resulting from the EXSYNC signal not accurately reflecting the object motion.

Continuously Smearred, Compressed or Stretched Images

When accurate synchronization is not achieved, the image appears smearred in the scan direction.

If the EXSYNC pulses are coming too fast, then the image will appear smearred and stretched in the machine direction. If the pulses are too slow, then the image will appear smearred and compressed.

Check the resolution of the encoder used to generate the EXSYNC pulses, along with the size of the rollers, pulleys, gearing, etc. to ensure that one pulse is generated for one pixel size of travel of the object.

It is also important that the direction of image travel across the sensor is matched to the camera's scan direction, as set by the user. See 'Scan Direction' in the user manual for more information.

If the scan direction is incorrect, then the image will have a significant smear and color artifacts in the scan direction. Changing the scan direction to the opposite direction should resolve this problem.

Refer to 'Camera Orientation' in the user manual to determine the correct direction orientation for the camera.



Note: The lens has a reversing effect on motion. That is, if an object passes the lens-outfitted camera from left to right, the image on the sensor will pass from right to left. The diagrams in the user manual take the lens effect into account.

Randomly Compressed Images

It is possible that when the scan speed nears the maximum allowed, based on the exposure time used, the image will be randomly compressed and possibly smeared for short periods in the scan direction.

This is indicative of the inspection systems transport mechanism dynamics causing momentary over-speed conditions. The camera can tolerate very short durations of over-speed, but if it lasts too long, then the camera can only maintain its maximum line rate, and some EXSYNC pulses will be ignored, resulting in the occasional compressed image.

The loss EXSYNC due to over-speed may also cause horizontal color artifacts.

Over-speeding may be due to inertia and / or backlash in the mechanical drive mechanism, causing variations around the target speed.

The greater the speed variation, the lower the target speed needs to be to avoid over-speed conditions. If the speed variation can be reduced by eliminating the backlash in the transport mechanism and / or optimizing the motor controller characteristics, then a higher target speed will be achievable.

Distorted Image when Slowing Down Changing Direction

The camera must align the rows in a fashion that accurately follows the object motion.

When the scan direction changes, then the process must reverse to match the reversed image motion across the sensor.

Only when all rows being accumulated have received the same image will the output be correct. Prior to this some lines have been exposed to one direction and other lines exposed to the opposite direction in the accumulated output.

Power Supply Issues

For safe and reliable operation, the camera input supply must be +12 V to +24 V DC.

The power supply to the camera should be suitably current limited, as per the applied input voltage.

Assume a worst case power consumption of +24 W and a 150% current rating for the breaker or fuse.



Note: The camera will not start to draw current until the input supply is above approximately 10.5 V and 200 msec has elapsed. If the power supply stabilizes in less than 200 msec, then inrush current will not exceed normal operating current.

It is important to consider how much voltage loss occurs in the power supply cabling to the camera, particularly if the power cable is long and the supply is operating at +12 V where the current draw is highest.

Reading the input supply voltage as measured by the camera will give an indication of the supply drop being experienced.

The camera tolerates "hot" unplugging and plugging.

The camera has been designed to protect against accidental application of an incorrect input supply, up to reasonable limits.

With the following input power issues, the status LED will be OFF:

- The camera will protect against the application of voltages above approximately +28 V. If the overvoltage protection threshold is exceeded, then power is turned off to the camera's internal circuitry. The power supply must be recycled to recover camera operation. The input protection circuitry is rated up to an absolute maximum of +30 V. Beyond this voltage, the camera may be damaged.
- The camera will also protect against the accidental application of a reverse input supply up to a maximum of -30 V. Beyond this voltage, the camera may be damaged.

Causes for Overheating & Power Shut Down

For reliable operation, the camera's face plate temperature should be kept below +65 °C and the internal temperature kept below +70 °C.

Many applications, such as in clean rooms, cannot tolerate the use of forced air cooling (fans) and therefore must rely on convection.

The camera's body has been designed with integrated heat fins to assist with convection cooling. The fins are sufficient to keep the camera at an acceptable temperature if convection flow is unimpeded.

The camera also benefits from conducting heat away from the body via the face plate into the lens extension tubes and camera mount. It is therefore important not to restrict convection airflow around the camera body, especially the fins and the lens assembly and camera mount. Lowering the ambient temperature will equally lower the camera's temperature.

If the camera's internal temperature exceeds +80 °C, then the camera will partially shut down to protect itself against damage.

Commands can still be sent to the camera to read the temperature, but the image sensor will not be operational and LVAL in response to line triggers will not be generated.

Additionally, the camera's power will reduce to approximately 70% of normal operation. If the camera's temperature continues to rise, at +90 °C the camera will further reduce its power to approximately 30% of normal operation and any communication with the camera will not be possible.

The only means to recover from a thermal shutdown is to turn the camera's power off. Once the camera has cooled down, the camera data can be restored by reapplying power to the camera.

Declaration of Conformity



EC & FCC DECLARATION OF CONFORMITY

We:
 Teledyne DALSA Inc., a business unit of Teledyne Digital Imaging, Inc.
 605 McMurray Road,
 Waterloo, Ontario, Canada,
 N2V 2E9

Declare under sole legal responsibility that the following products conform to the protection requirements of council directive 2014/30/EU on the approximation of the laws of member states relating to electromagnetic compatibility and are CE-marked accordingly:

HL-HM-32K15S-00-R

The products to which this declaration relates are in conformity with the following relevant harmonized standards, the reference numbers of which have been published in the Official Journal of the European Communities:

EN55032 (2015)	Electromagnetic compatibility of multimedia equipment — Emission requirements
EN55011 (2015) with A1(2016)	Industrial, scientific and medical equipment — Radio-frequency disturbance characteristics — Limits and methods of measurement
EN 61326-1 (2013)	Electrical equipment for measurement, control and laboratory use — EMC requirements — Part 1: General requirements
EN 55024 (2010)	Information technology equipment — Immunity characteristics — Limits and methods of measurement
EN 55035 (2016)	Electromagnetic compatibility of multimedia equipment – Immunity requirements

Further declare under our sole legal responsibility that the product listed also conforms to the following international standards:

CFR 47	Part 15 (2008), subpart B, for a class A product. Limits for digital devices
ICES-003	Information Technology Equipment (ITE) — Limits and Methods of Measurement
CISPR 11(2015) with A1 (2016)	Industrial, scientific and medical equipment - Radio-frequency disturbance characteristics - Limits and methods of measurement
CISPR 32 (2015)	Electromagnetic compatibility of multimedia equipment - Emission requirements
CISPR 35 (2016)	Electromagnetic compatibility of multimedia equipment - Immunity requirements

Note: this product is intended to be a component of a larger industrial system. It is not intended for use in a residential system.

Waterloo, Canada
 Location

2018-11-20
 Date

Cheewee Tng, P. Eng.
 Director, Quality Assurance

THIS IS AN UNCONTROLLED COPY OF A CONTROLLED DOCUMENT PRINTED 11/20/2019 8:24 AM
 The information contained herein is proprietary to TELEDYNE DALSA and is to be used solely for the purpose for which it is supplied. It shall not be disclosed in whole or in part, to any other party, without the express permission in writing by TELEDYNE DALSA.

Document Revision History

Table 19: Document Revision History

Revision	Description	Date
00	Initial release.	November 20, 2019



TELEDYNE DALSA
Everywhereyoulook™

Contact Information

Sales Information

Visit our web site:	http://www.teledynedalsa.com/en/products/imaging/
Email:	mailto:info@teledynedalsa.com

Canadian Sales	
Teledyne DALSA — Head office 605 McMurray Road Waterloo, Ontario, Canada, N2V 2E9 Tel: 519 886 6000 Fax: 519 886 8023	Teledyne DALSA — Montreal office 880 Rue McCaffrey St. Laurent, Quebec, Canada, H4T 2C7 Tel: (514) 333-1301 Fax: (514) 333-1388
USA Sales	European Sales
Teledyne DALSA — Billerica office 700 Technology Park Drive Billerica, Ma. 01821 Tel: (978) 670-2000 Fax: (978) 670-2010	Teledyne DALSA GMBH Lise-Meitner-Str. 7 82152 Krailling (Munich), Germany Tel: +49 - 89 89545730
Asian Sales	
Teledyne DALSA Asia Pacific Ikebukuro East 13F 3-4-3 Higashi Ikebukuro, Toshima-ku, Tokyo, Japan Tel: +81 3 5960 6353 Fax: +81 3 5960 6354	Shanghai Industrial Investment Building Room G, 20F, 18 North Cao Xi Road, Shanghai, China 200030 Tel: +86-21-64279081 Fax: +86-21-64699430

Technical Support

Submit any support question or request via our web site:

Technical support form via our web page:
Support requests for imaging product installations,
Support requests for imaging applications

Camera support information

Product literature and driver updates

<http://www.teledynedalsa.com/mv/support>