

대면적·협소공간 검사를 위한 CIS 카메라 솔루션

· Application 맞춤 CIS 카메라
+ 조명 솔루션



바이렉스 김승엽 대표

010 - 9084 - 2927 | virex.co.kr | ts@virex.co.kr



코엑스 B홀, B710 바이렉스

Table of Contents

목차.

01

라인스캔 카메라 컨셉 및 한계점

03

CiS카메라 제품 소개

05

2.5D Photometric Stereo
CIS 소개

06

Application#2
: Wafer 검사 솔루션

02

CIS 카메라 컨셉소개

04

Color CIS 소개

06

Application#1
: PCB 검사 솔루션

“

Smaller System,
Faster Integration,
Greater Flexibility

”



01

기존 라인스캔 카메라 컨셉 및 한계점

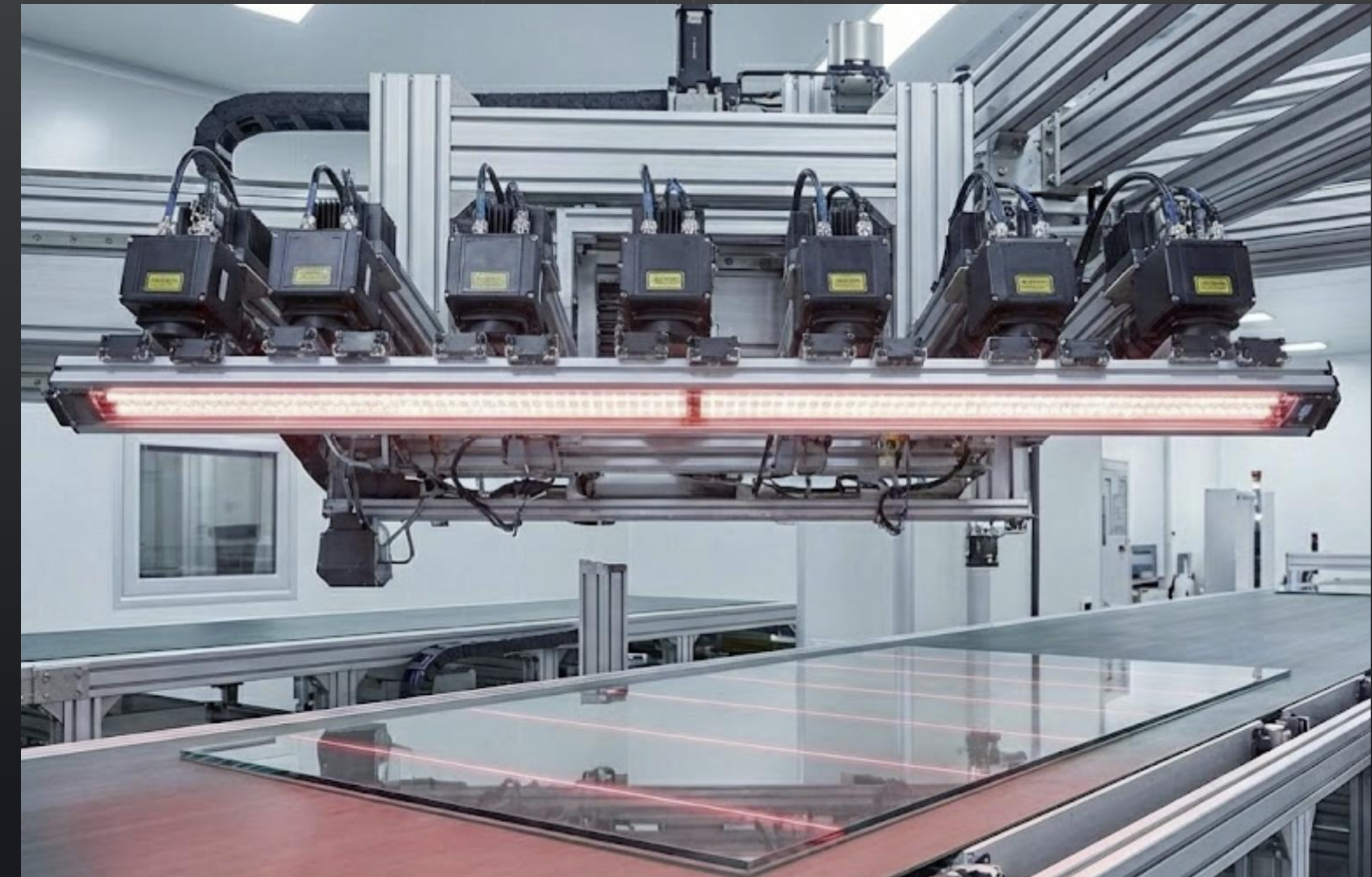

라인스캔 카메라 컨셉

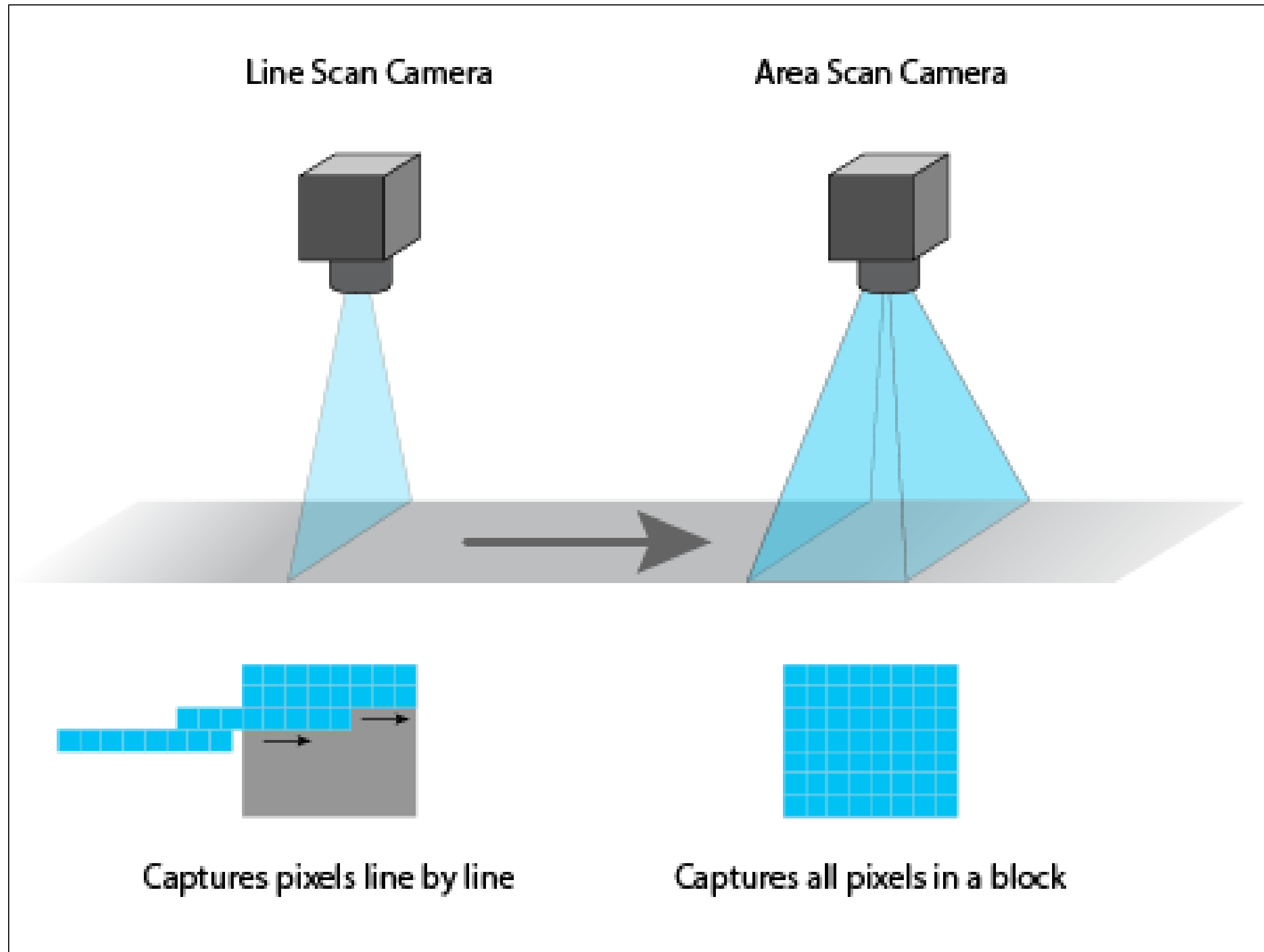

| 구분 | Line Scan 방식 | Area Scan 방식 |
|----------|--------------------------------|-----------------------------|
| 이미지 획득 | 1차원 라인-> 2차원 이미지를 만듦 | 한 번의 촬영으로 2차원 이미지를 얻음 |
| 적합한 대상 | 고속으로 움직이는 물체, 연속적인 웹(필름, 종이 등) | 멈춰 있거나, 순간적으로 정지시킬 수 있는 물체 |
| 설치난이도 | 높음 (정렬·조명 복잡) | 낮음 |
| 비용/구조 | 고가 / 고속 장비 중심 | 저비용 / 범용 시스템 |
| 조명 | 밝고 균일한 연속 조명 필수 | 일반적인 조명 |
| 해상도 | 세로 해상도의 제약 x | 세로 해상도의 제약 0 |
| 대표 적용 분야 | FPD, 필름, 배터리, 웹 검사 | 부품검사, 로봇비전, 3D측정, 일반 산업용 검사 |

<Line Scan vs Area Scan Image Acquisition concept>

라인스캔 카메라 컨셉

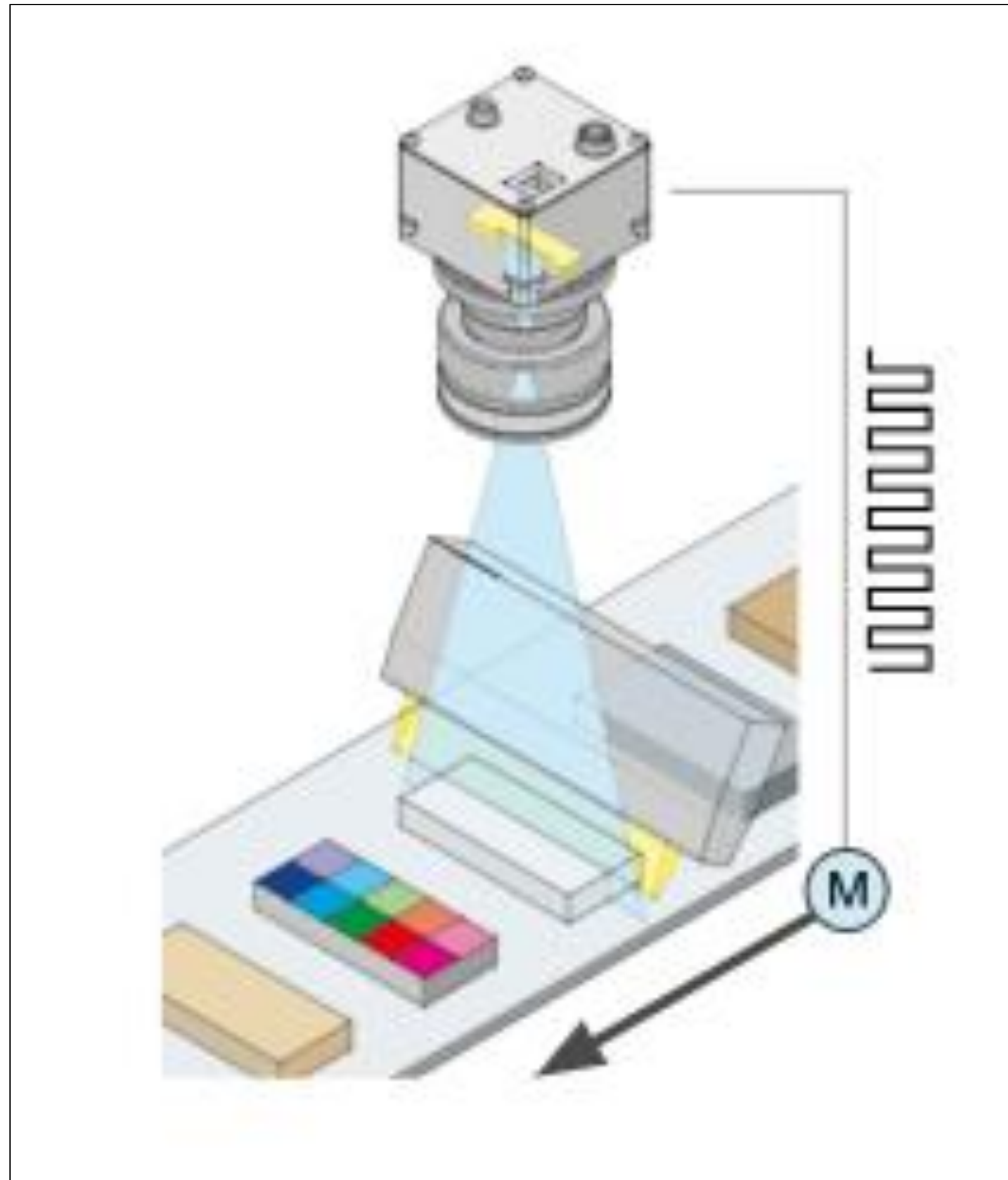

라인스캔 작동에 필요한 구성요소

| | |
|-------------------|------------------|
| 카메라 | 렌즈 + 경통 + 광학필터 |
| 외부조명 | 조명컨트롤러 |
| 프레임그래버 | 산업용PC |
| 각종 데이터, 전원, IO케이블 | 엔코더시그널 or 트리거분배기 |
| 기구 정밀 세팅 작업 | |

대면적 라인스캔 카메라의 한계점

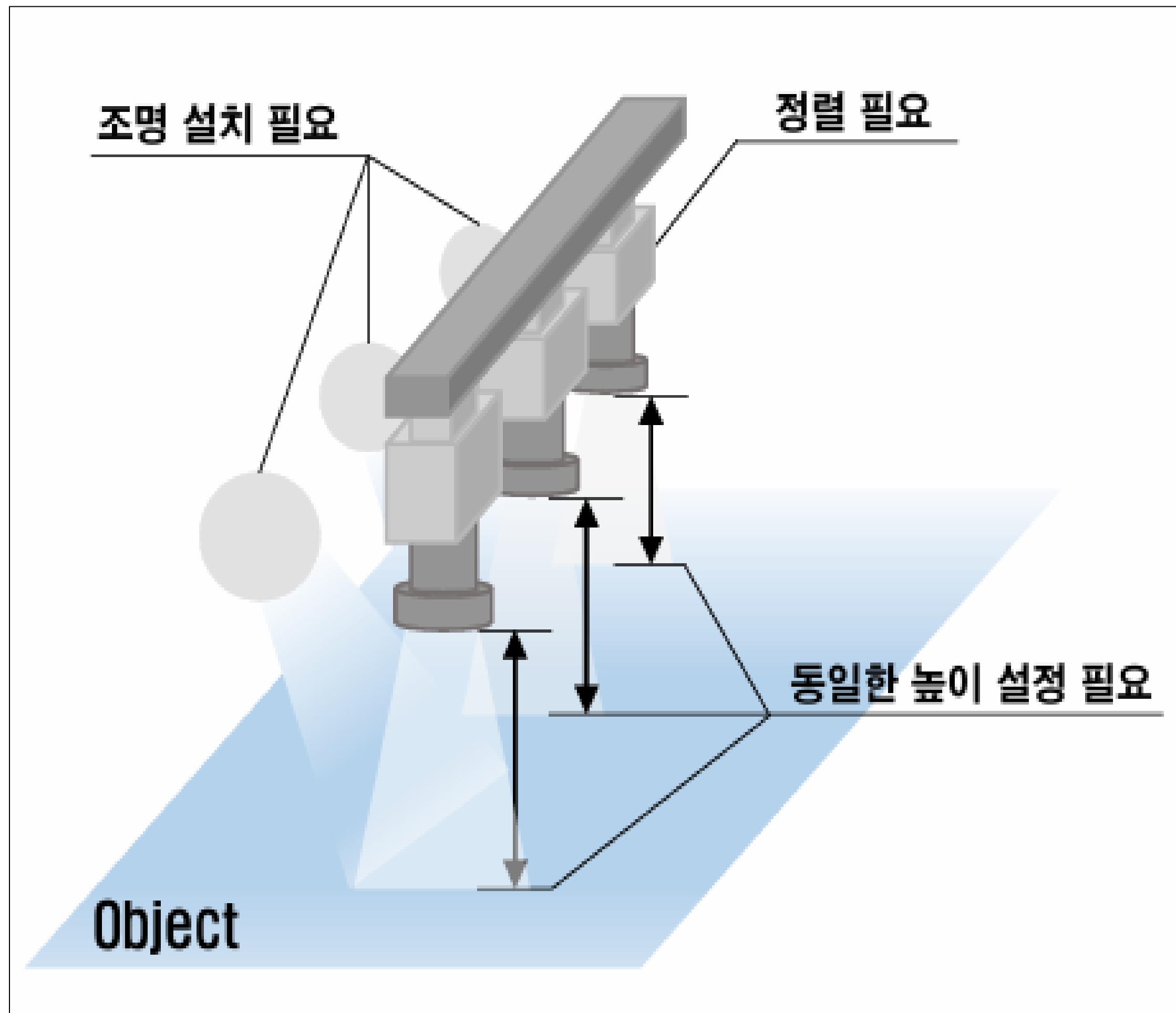

1. 넓은 설치공간(Z축방향)
2. 카메라 간 **오버랩 구간 이미지 정합** 필요
3. **왜곡된 이미지 정합**의 어려움
4. 기구적으로 **진동에 취약**해 영상왜곡을 초래
5. 조명이 멀리 있어서 전체 이미지 영역에서 광이 불균일하게 들어감
 - ➔ 보이지 않는 **작은 결함을 찾아내기 어려움**
6. 이미지 전영역에 대한 **Uniformity 떨어짐**
7. 기구 얼라인 **작업 소요시간 증가**

대면적 라인스캔 카메라의 한계점

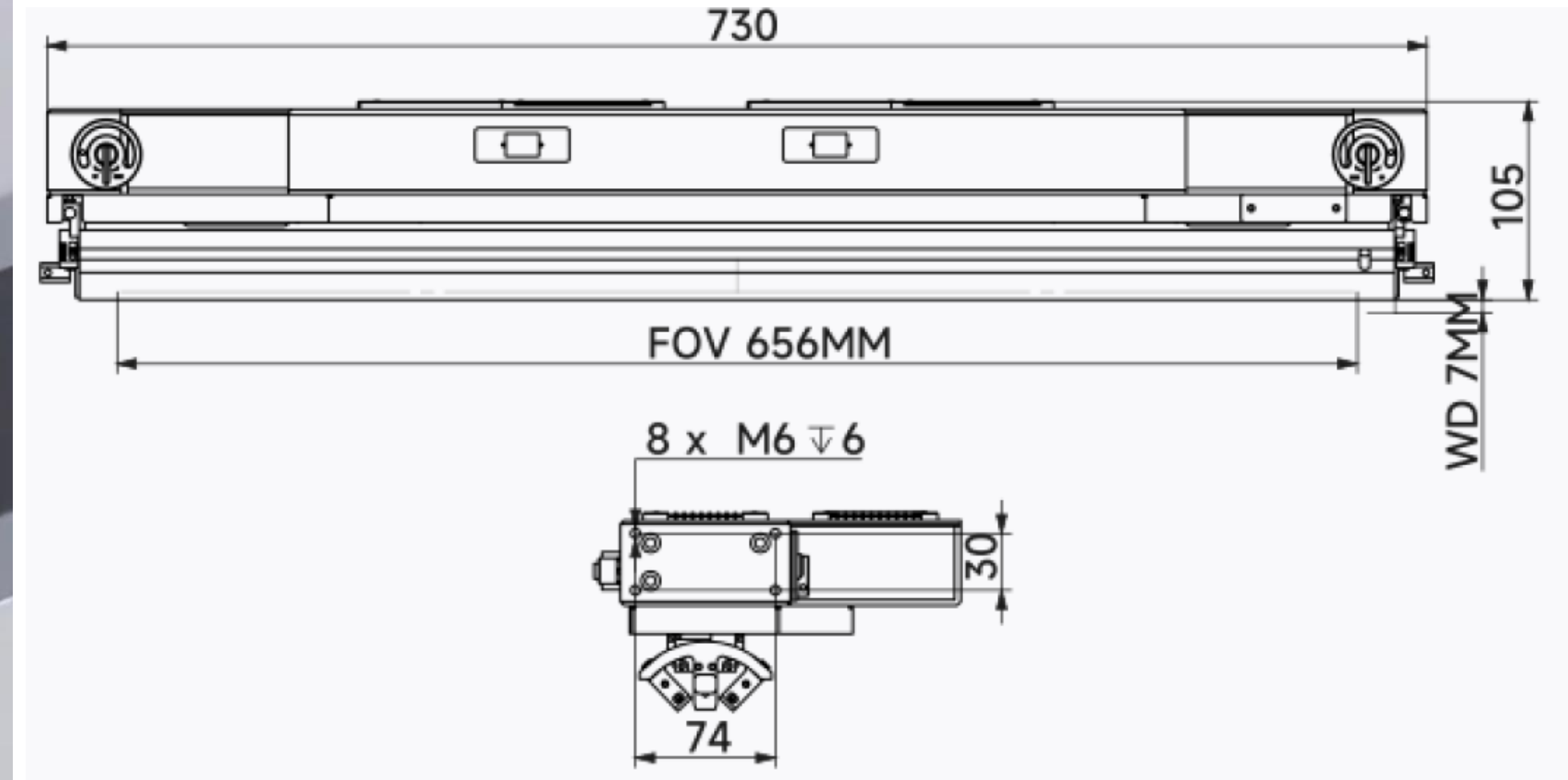
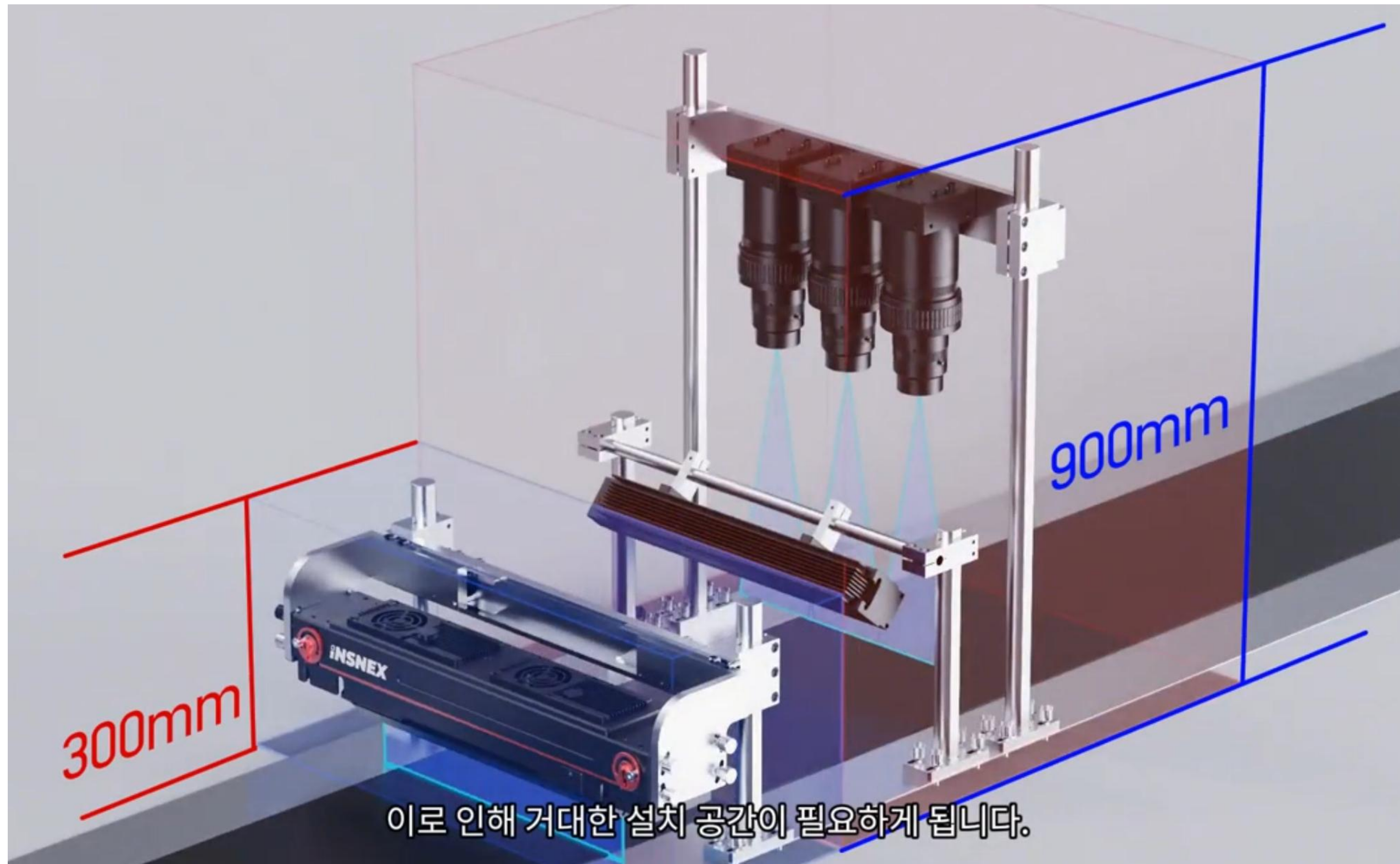

02

CIS 카메라 컨셉 소개 (Contact Image Sensor)

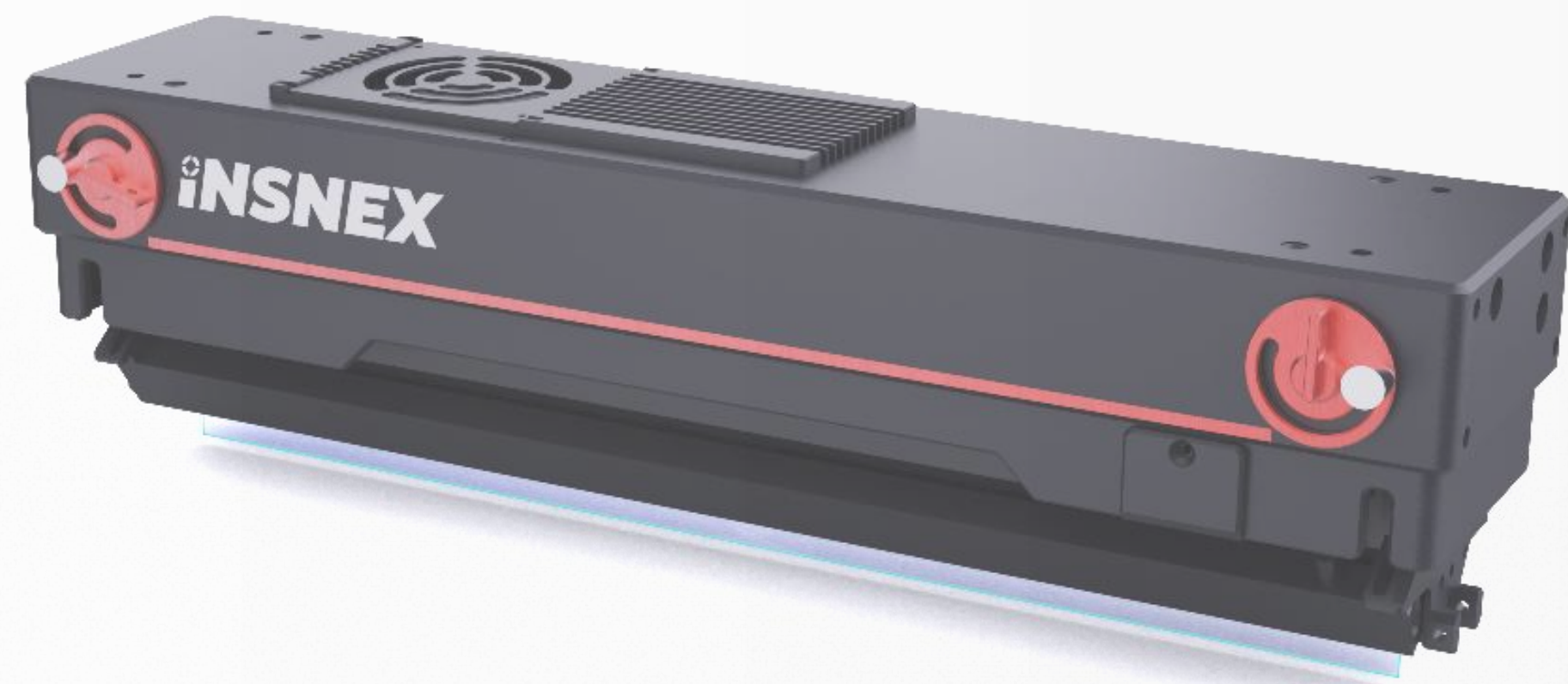

CIS 카메라 구조

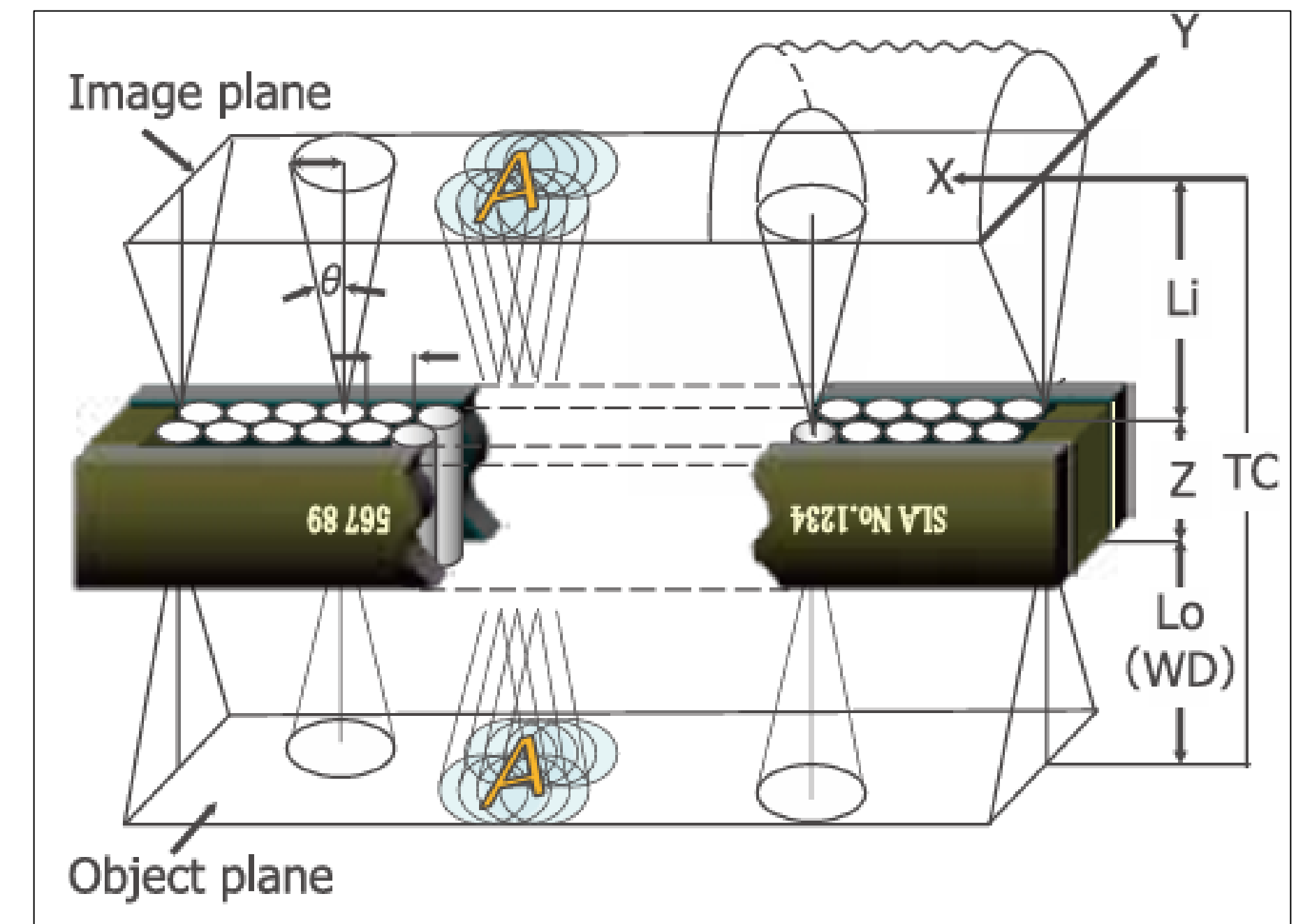
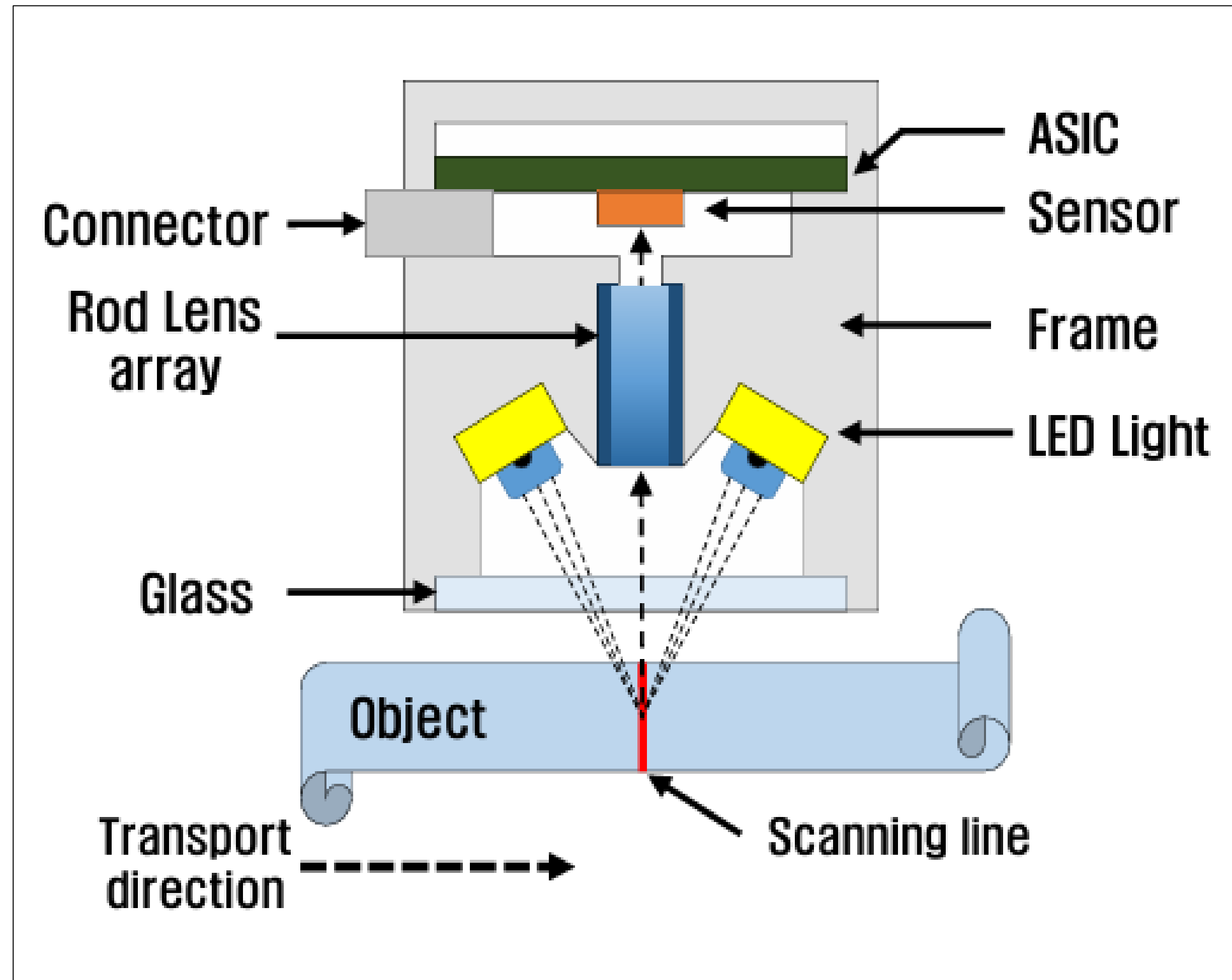

Rod Lens Array = SLA Lens

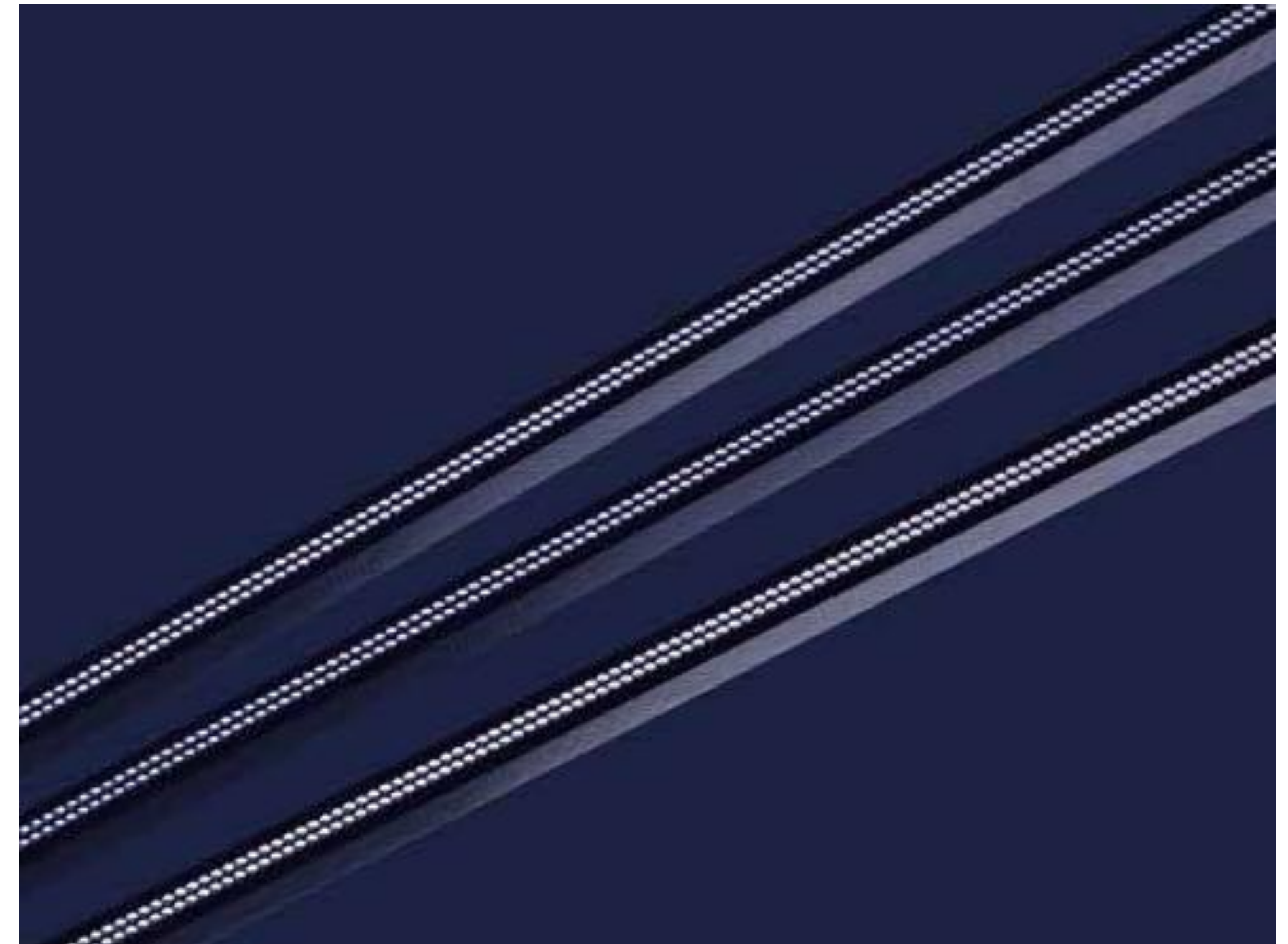
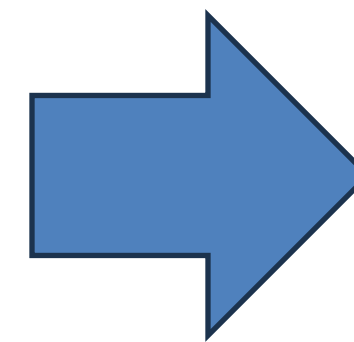

<Rod Lens>

<Rod Lens Array = SLA Lens>

**SLA: Selfoc Lens Array

Rod Lens vs 일반렌즈

| 구분 | Rod 렌즈 Array(SLA 렌즈) | 일반 렌즈(Glass Lens) |
|---------|-------------------------|-------------------|
| 초점형성 방식 | 내부 굴절률 분포로 초점 형성 | 곡면 형상으로 초점 형성 |
| 광학 왜곡 | 거의 없음 | 렌즈 중심부/가장자리 왜곡 존재 |
| 초점 거리 | 짧음 (수 mm) | 길음 (수십~수백 mm) |
| 조정 필요성 | 없음 (고정 초점) | 고정초점 or 포커스 조정 필요 |
| 크기 / 두께 | 매우 작음 (Compact) | 상대적으로 큼 |
| 조립 정렬 | 불필요 | 정밀 정렬 필요 |
| 대표 응용 | CIS, 스캐너, OCR, 소형 비전 모듈 | 카메라, 현미경, 프로젝터 |

CIS카메라 강점 (vs 라인스캔 카메라)

| 구분 | CIS 카메라 | 라인스캔 카메라 |
|-------------|------------------------------------|---------------------------------|
| 광학구성 | 렌즈+조명+센서 일체형 (*외부조명 사용 가능) | 렌즈+조명+센서 분리형 |
| 설치공간 | 협소공간 설치 가능 기존 검사장비/공정장비에에 탑재 가능 | 넓은 설치 공간 필요 |
| 기구정렬 / 유지보수 | 간단한 정렬, 유지보수 용이 | 정렬 복잡, 세밀한 조정 필요 유지보수 어려움 |
| 검사폭 확장성 | 모듈 병렬 확장으로 대면적 대응 | 렌즈 한계 및 영상 합성 어려움 검사폭 확장 제한적 |
| 시스템 크기 | 매우 컴팩트, 장비 소형화 용이 | 크고 복잡 |
| 영상품질 | 광학 왜곡 ≒0%, 균일한 이미지 | 광학 왜곡 및 이미지 정합 오차 발생 가능 |
| 해상도 | 300(84um)~7,200(3.5um)dpi | 다양(렌즈/센서에 의존) |

CIS강점#1: 협소한 공간 CIS 설치 사례

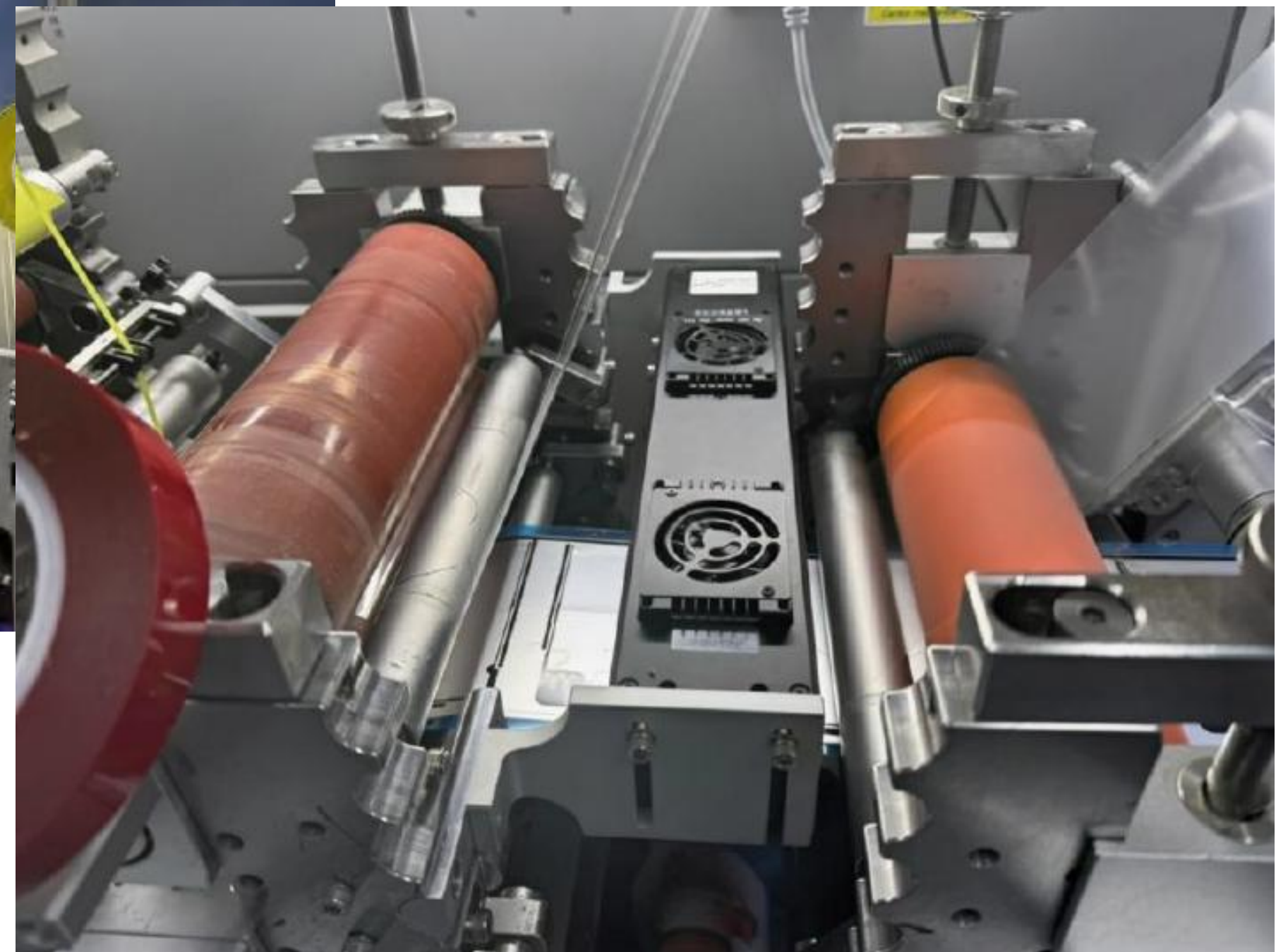
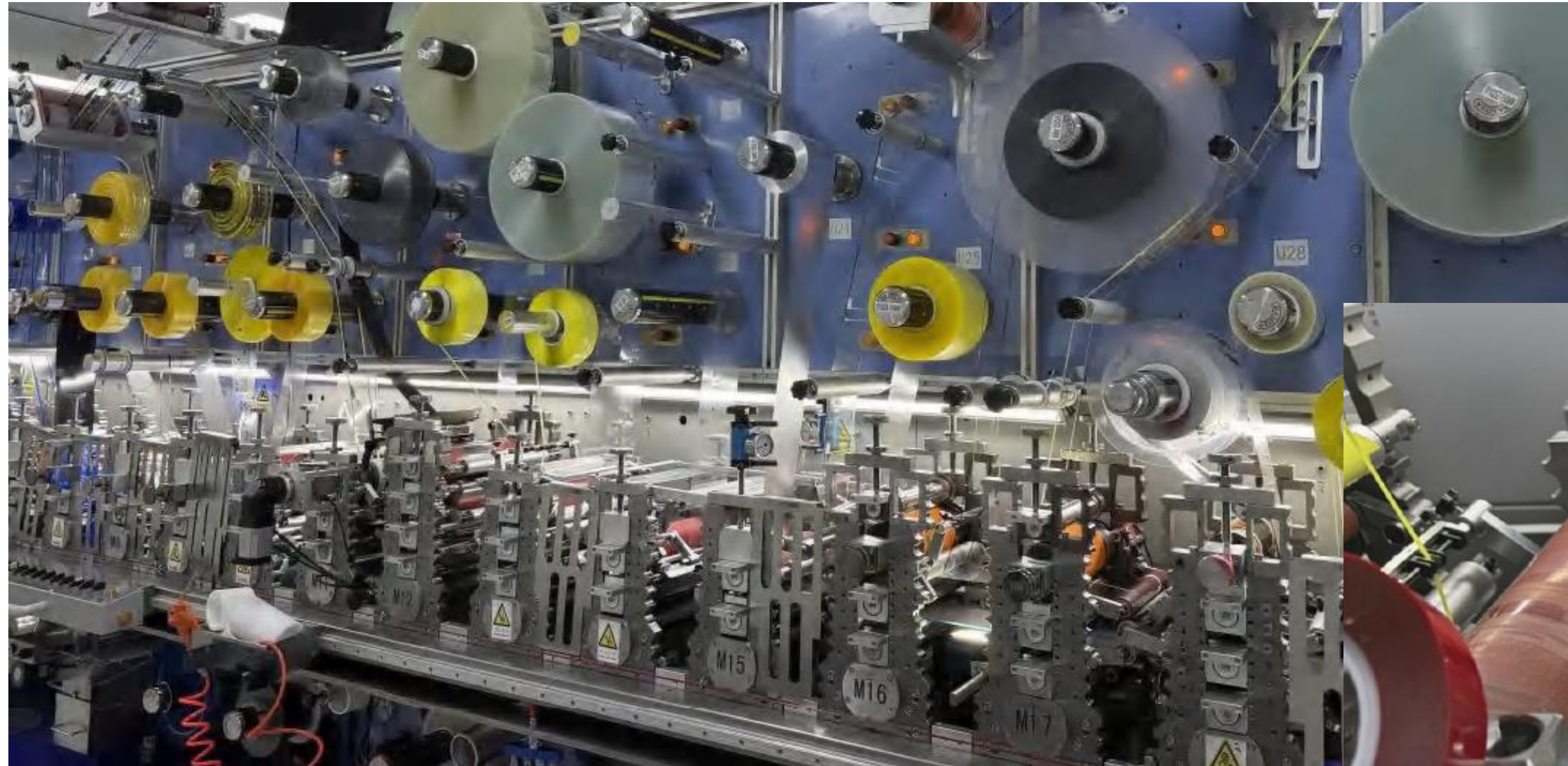

<Circular Cutter Machine>

CIS강점#1: 협소한 공간 CIS 설치 사례

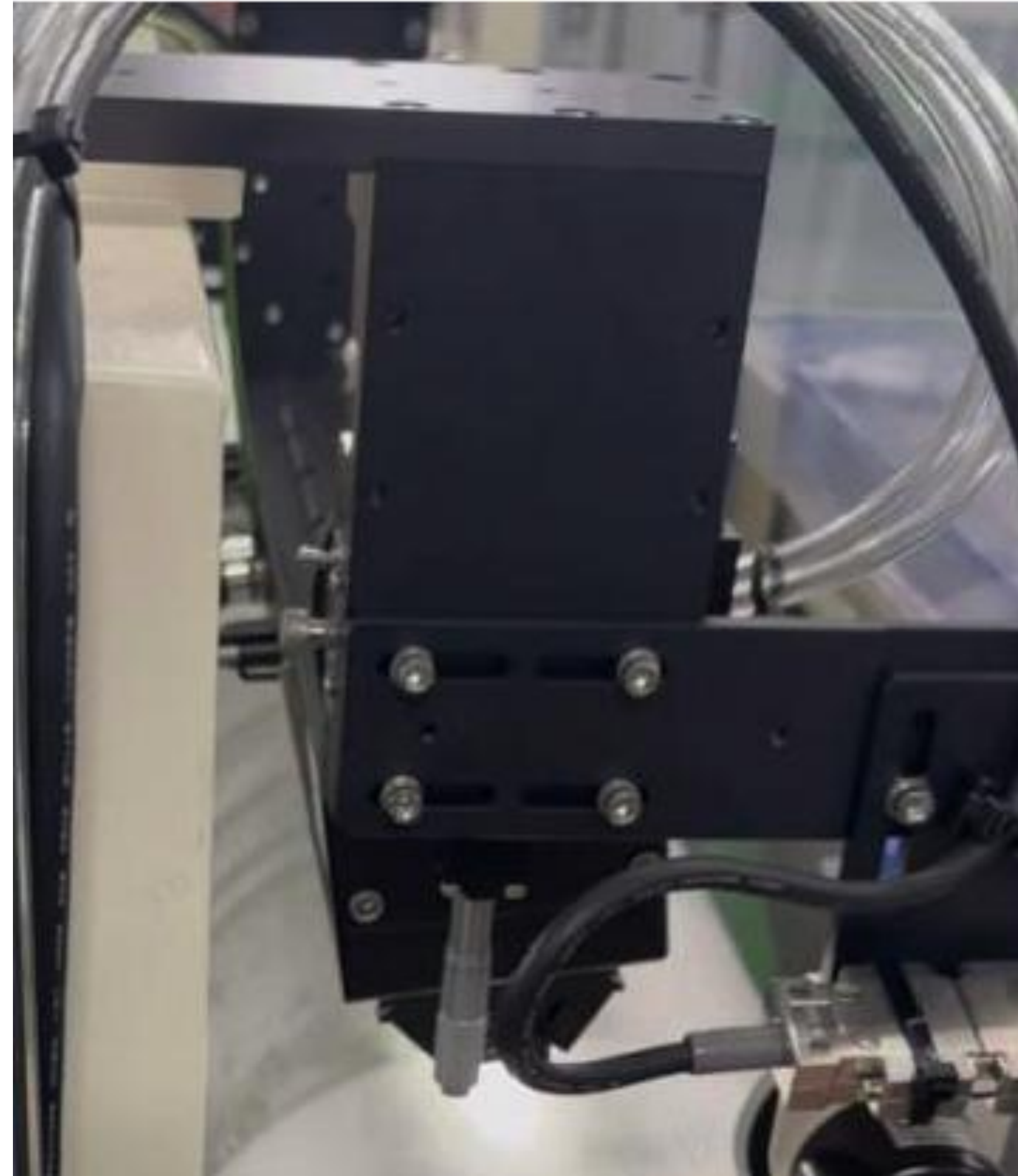

<원형커팅머신 CIS카메라 설치된 측면 사진>

CIS강점#1: 협소한 공간 CIS 설치 사례(공정수율개선)



CIS강점#1: 협소한 공간 CIS 설치 사례(장비사이즈 축소)

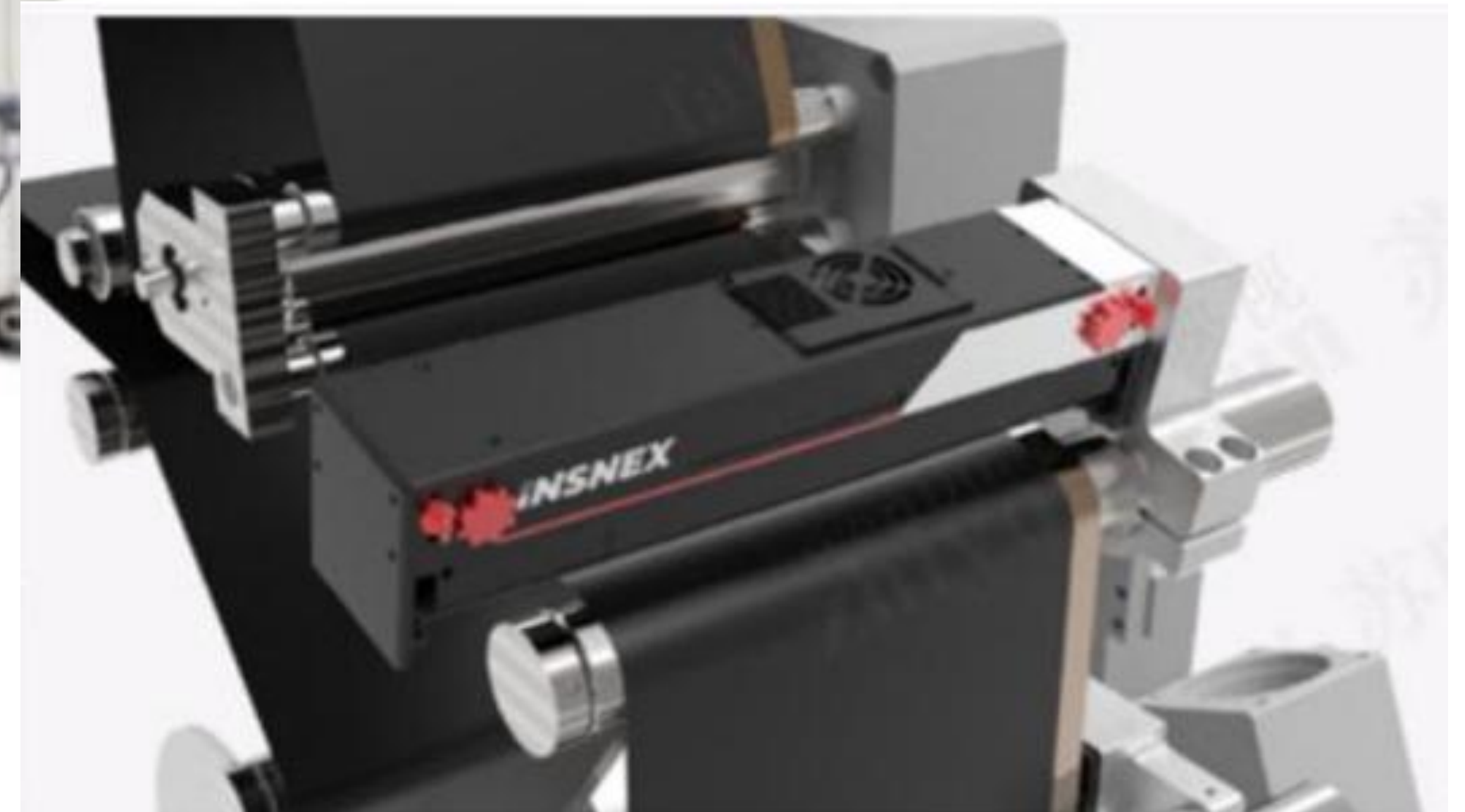

CIS강점#2: 광학 왜곡 $\approx 0\%$

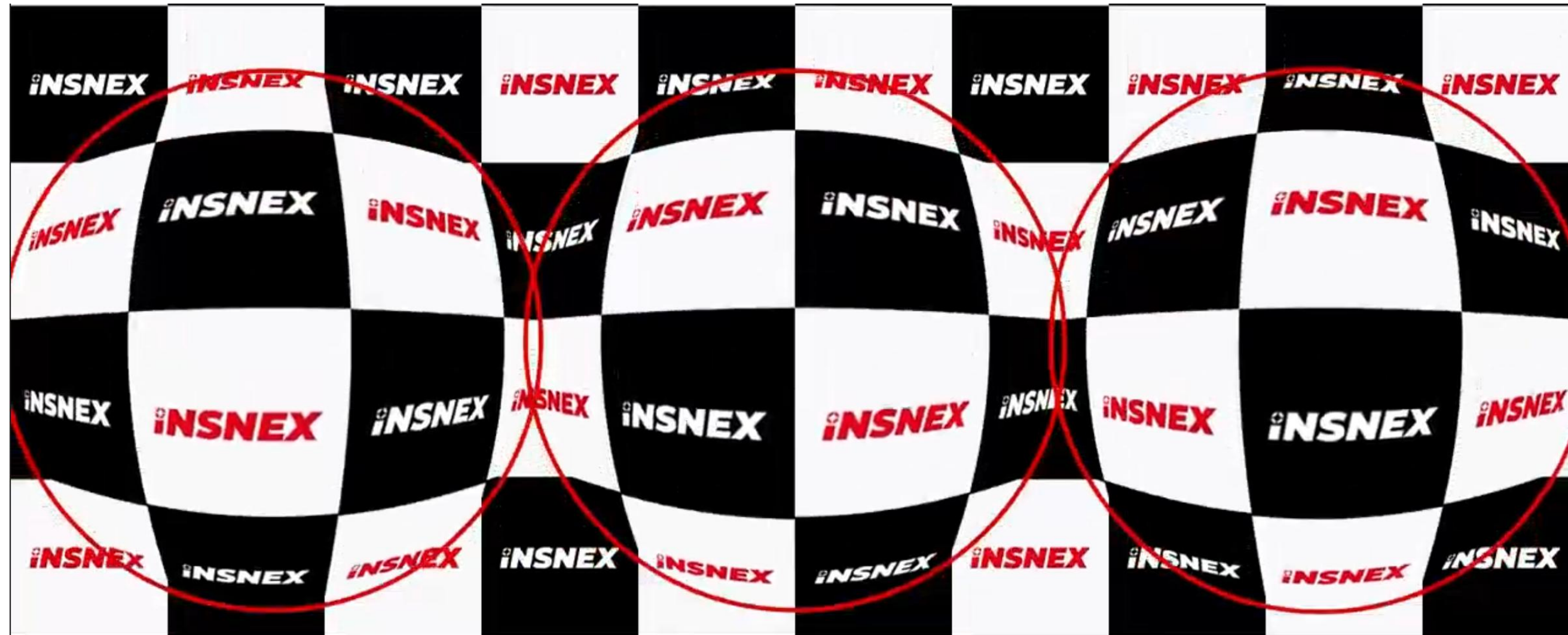

<3대의 라인스캔 카메라 이미지>



<1대 CIS 카메라 이미지>



CIS강점#2: 광학 왜곡 $\approx 0\%$

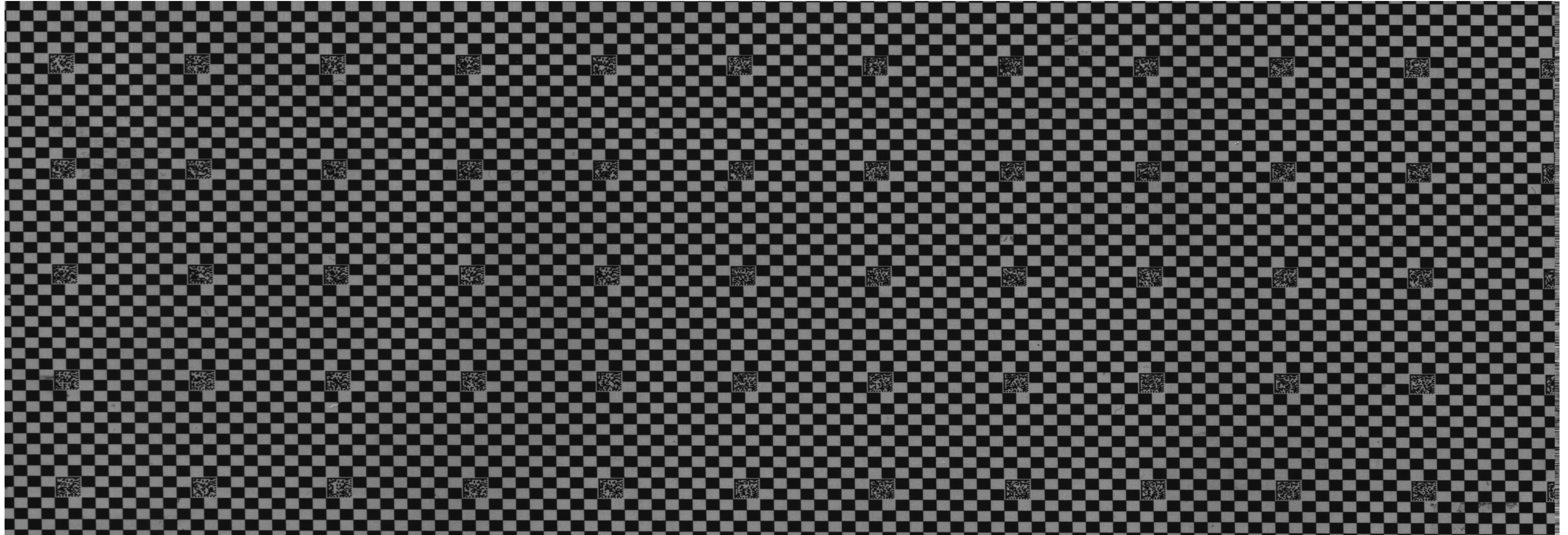

03

CIS 카메라 제품소개 (Contact Image Sensor)



CIS카메라 Line-up

| 제품군 | WD | Resolution | Scan Width Range | Scan Speed Range | 2.5D 유무 |
|--------|---------|----------------------|------------------|-------------------|---------|
| CHVS | 15~50mm | 300/600/1200 DPI | 190~1550 mm | 36/66/110/150 kHz | X |
| LXM | 7~30mm | 900/1800/3600 DPI | 50~1476 mm | 40/80/120/160 kHz | X |
| LX2.5D | 15~30mm | 600/900/1800 DPI | 311~1550 mm | 94 kHz | O |

| DPI | 7,200 | 4,800 | 3,600 | 2,400 | 1,800 | 1,200 | 900 | 600 | 300 |
|--------------------------------|-------|-------|-------|-------|-------|-------|-----|-----|-----|
| Pixel Resolution [um/pixel] | 3.5 | 5.25 | 7 | 10.5 | 14 | 21 | 28 | 42 | 84 |



CIS Core Technology#1: Seamless CIS Sensor

전통CIS센서 vs CMOS CIS센서

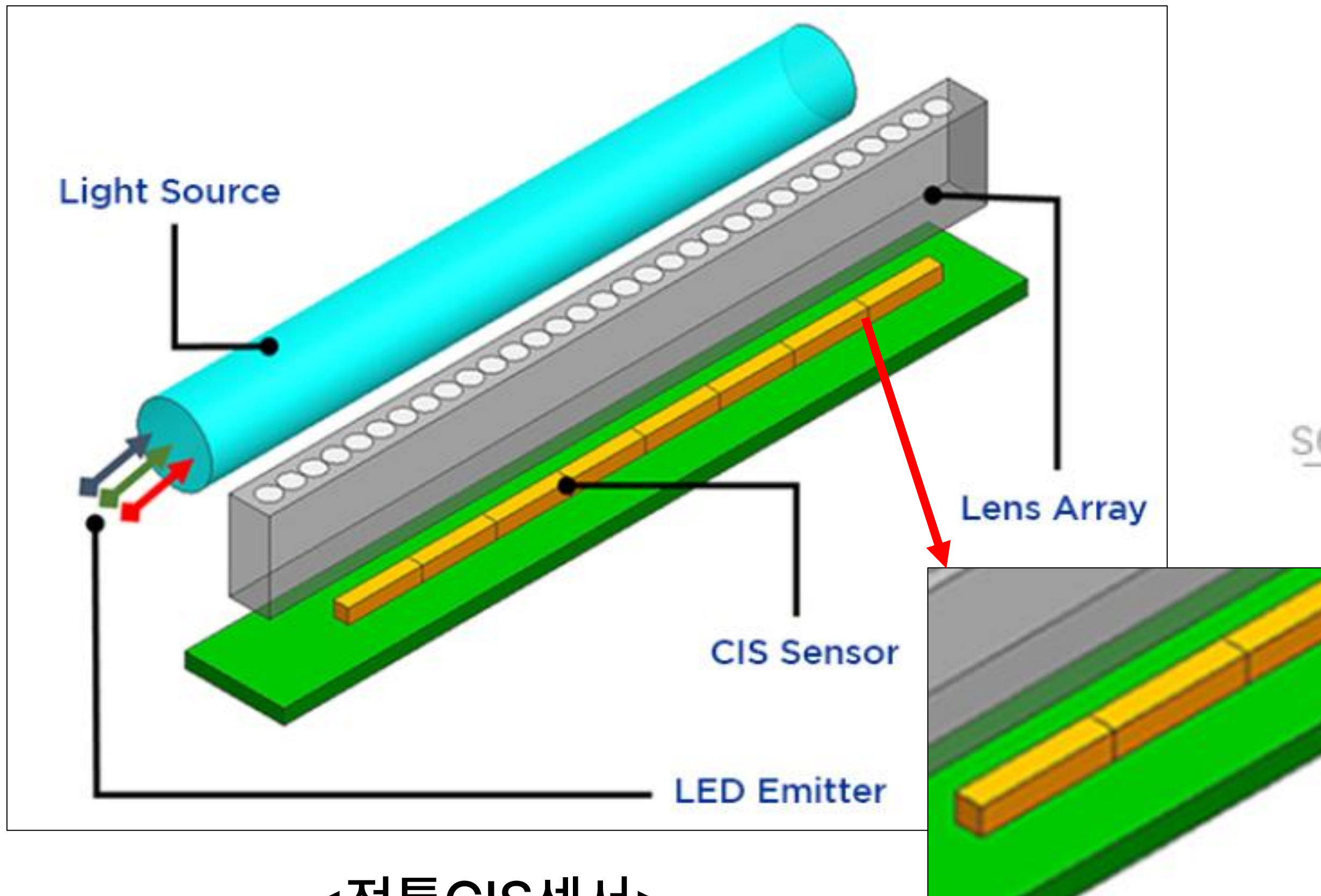

<전통CIS센서>

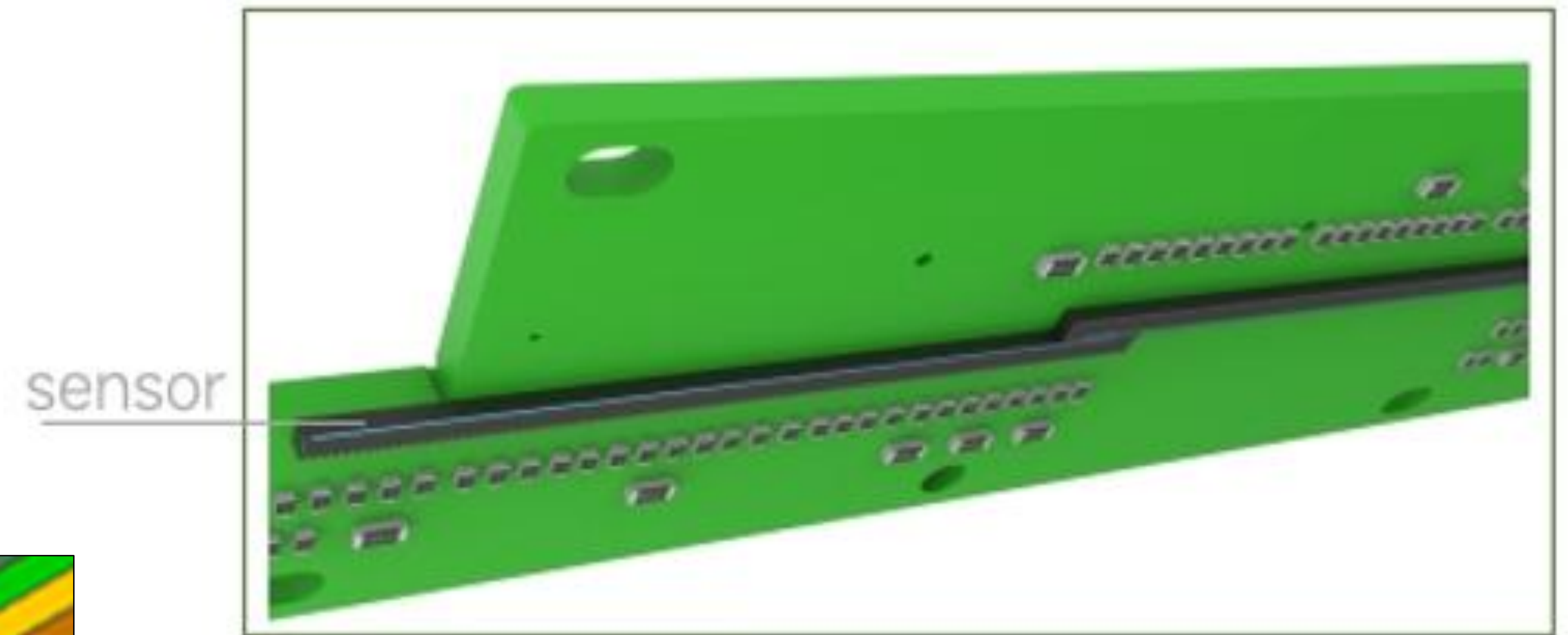

<라인스캔 CMOS기반 CIS 센서>

CIS Core Technology#1: Seamless CIS Sensor

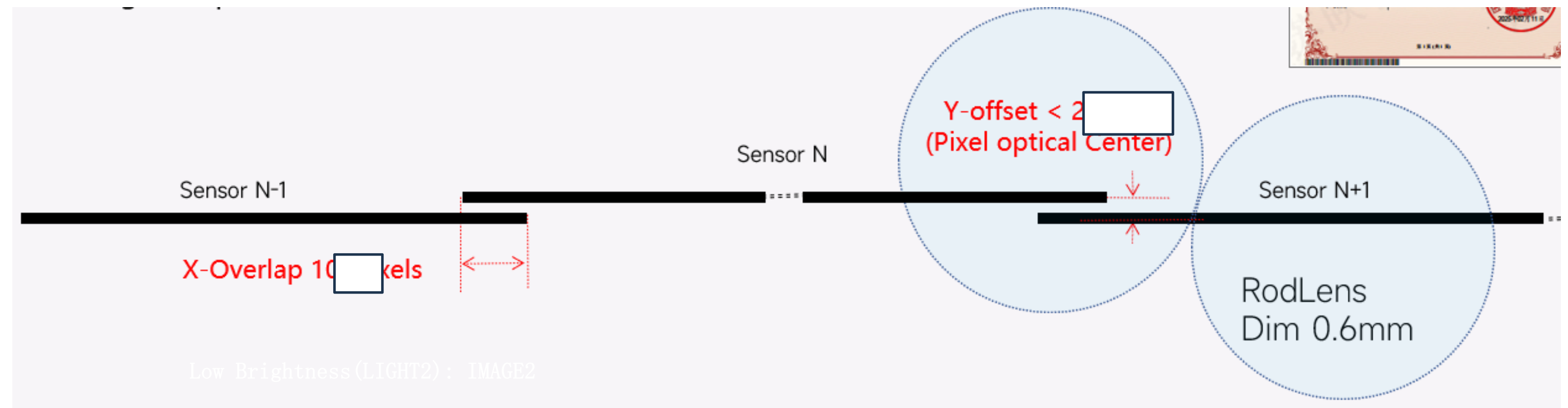
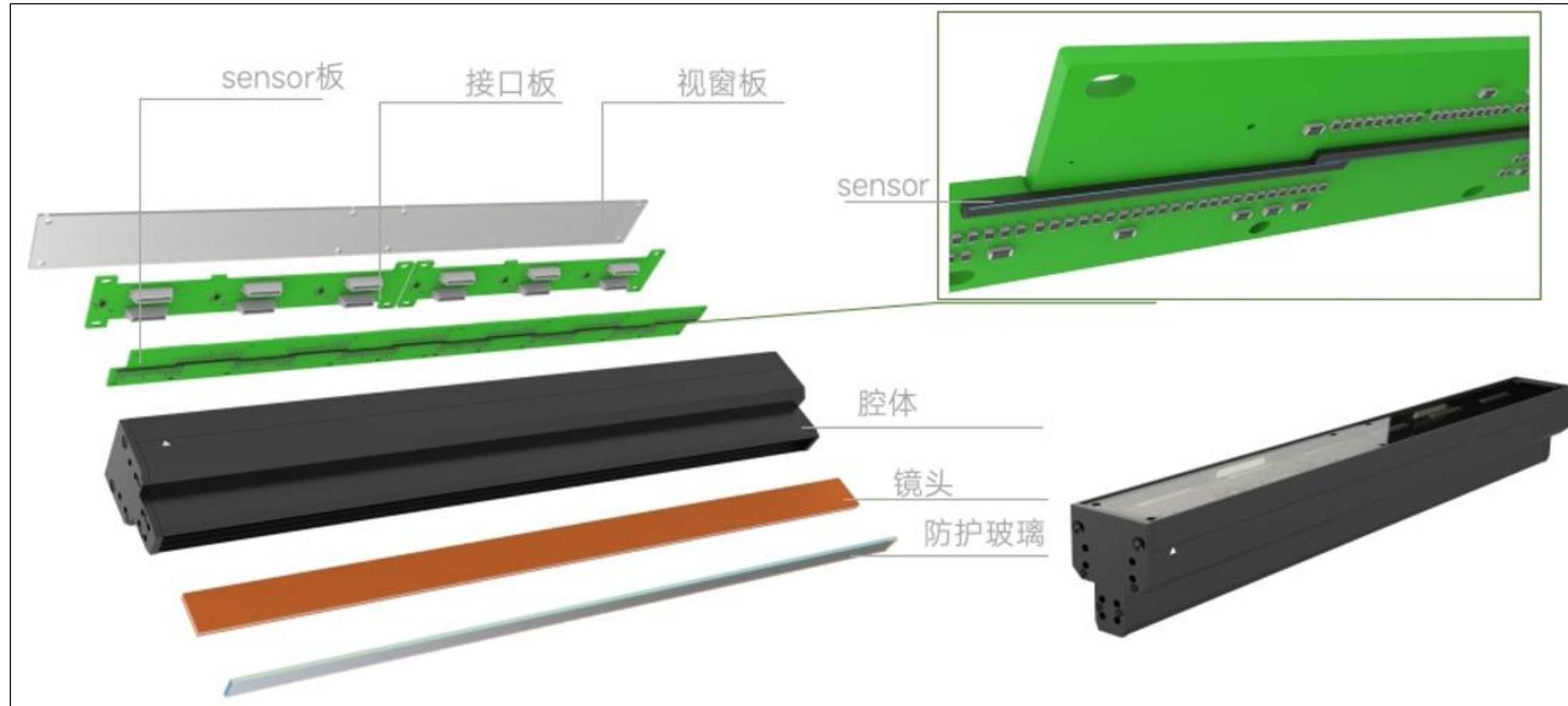

CIS Core Technology#2: Image Calibration

White Target 촬영 이미지

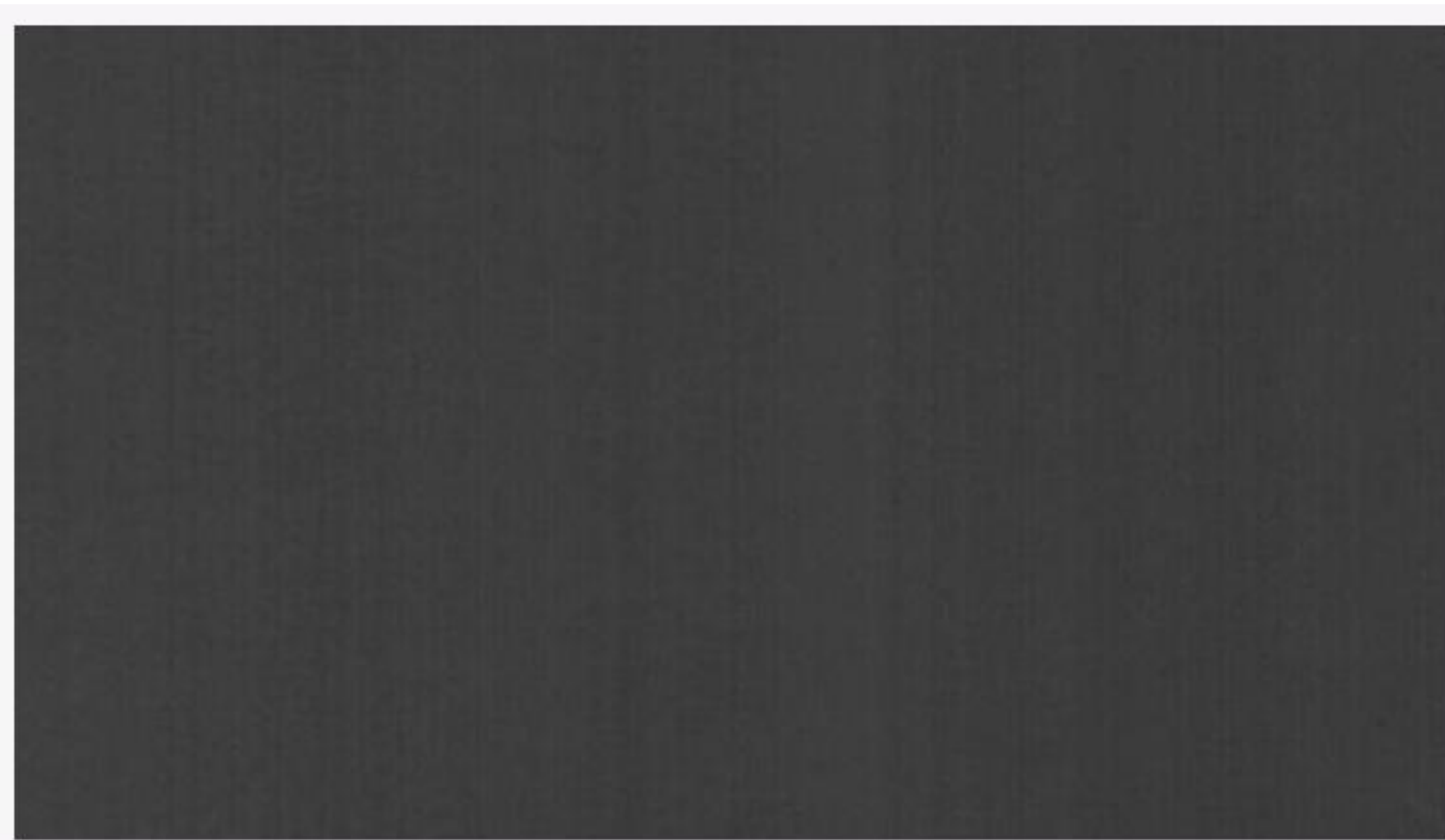

<전통 CIS센서 실제 촬영 이미지 / A社>

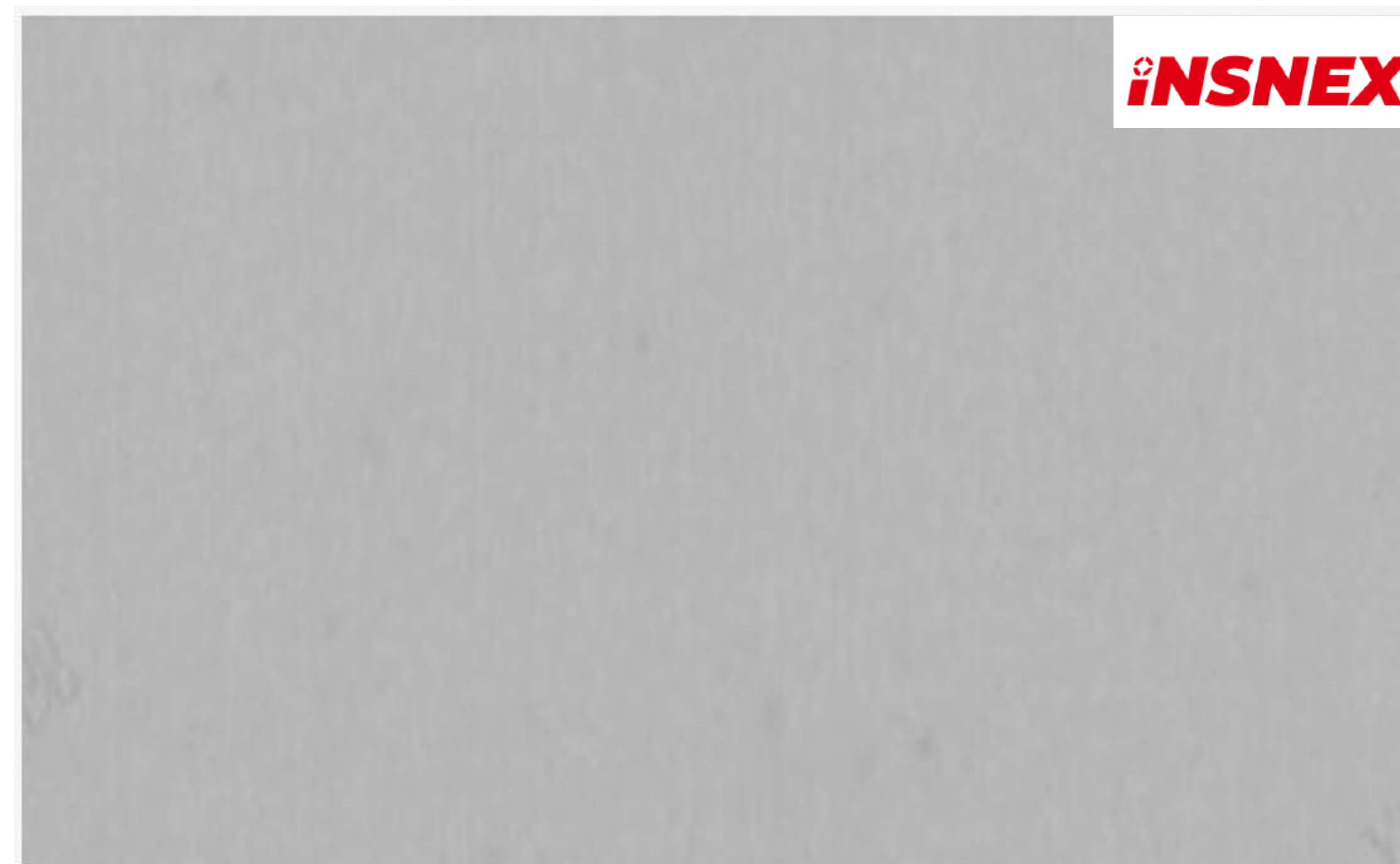

< 전통 CIS센서 실제 촬영 이미지 / 인스넥스社 >

CIS Core Technology#2: Image Calibration

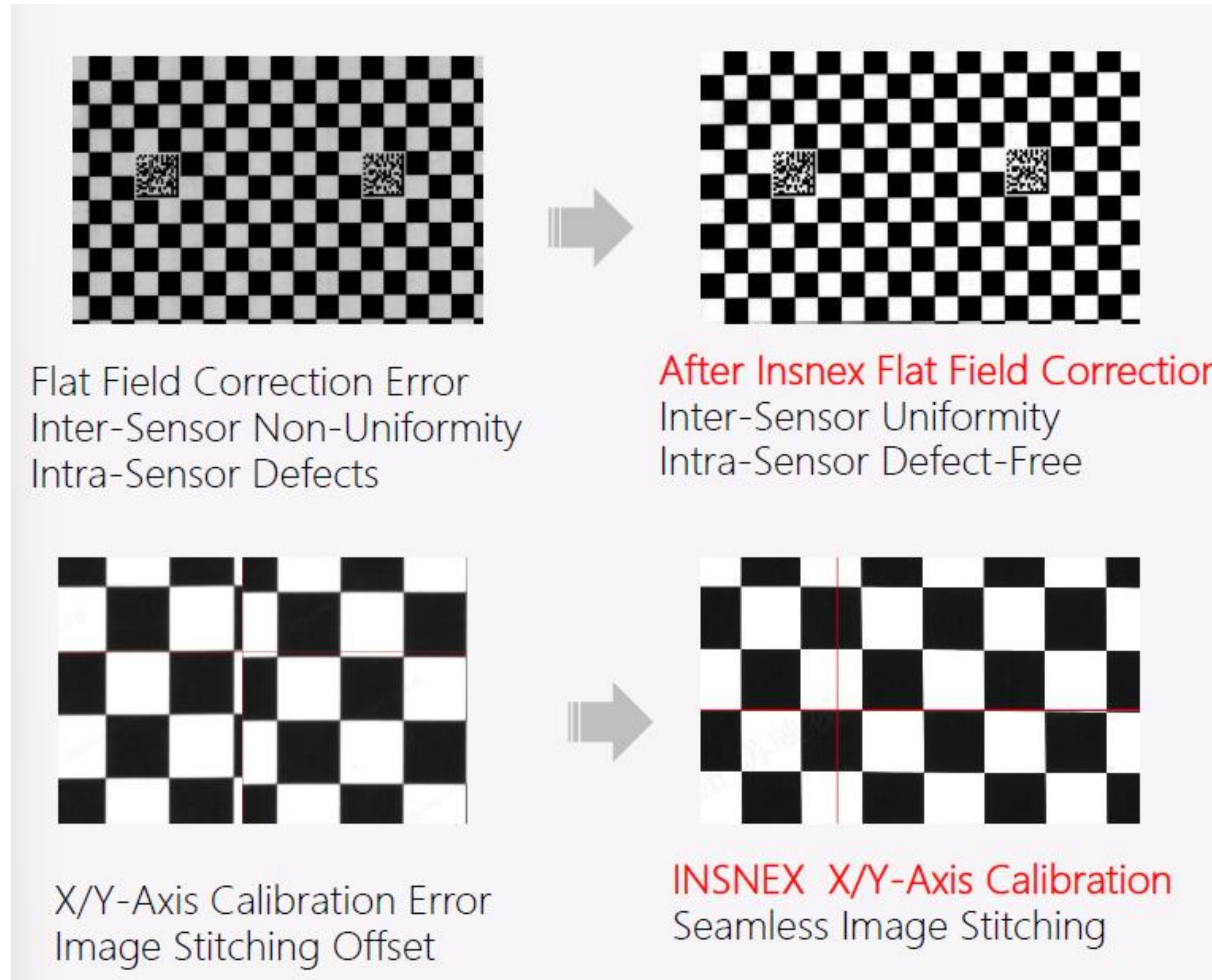

3,600dpi CIS Camera

(세계최초 7um/px 분해능 CIS카메라)

3,600dpi 카메라 사양

Model: LineX CIS Max Pro

Pixel Resolution: 7um/px

FOV: 50~1,476mm

WD: 7~15mm

Interface: 10GigE or 40GigE

Line Rate: 40~150kHz

Chromatic: Mono or Color

Light: internal or external light



04

Color CIS 소개

우수한 컬러 재현성을 자랑하는 Color CIS

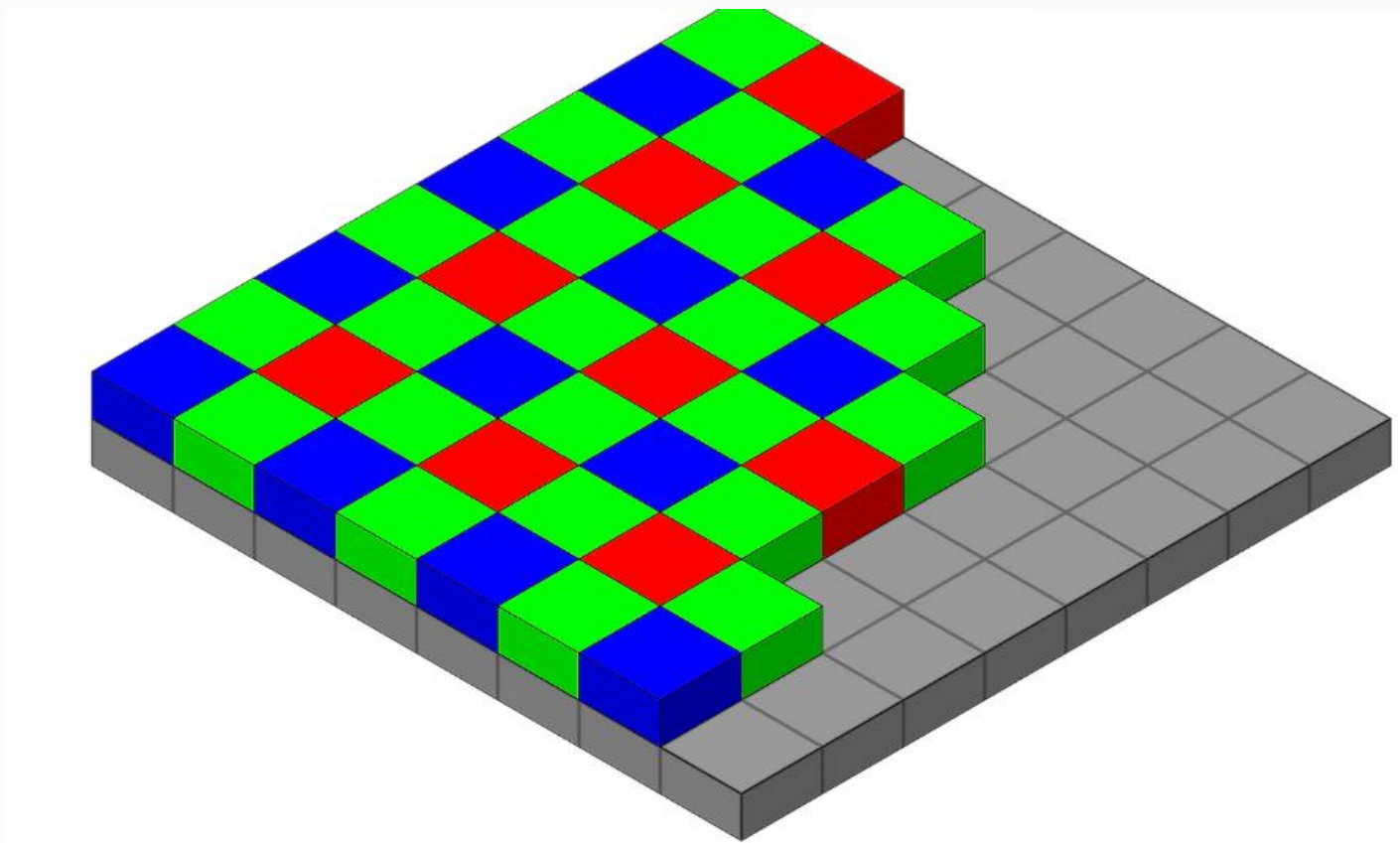

CIS Color vs 3CMOS급 Color Line Scan

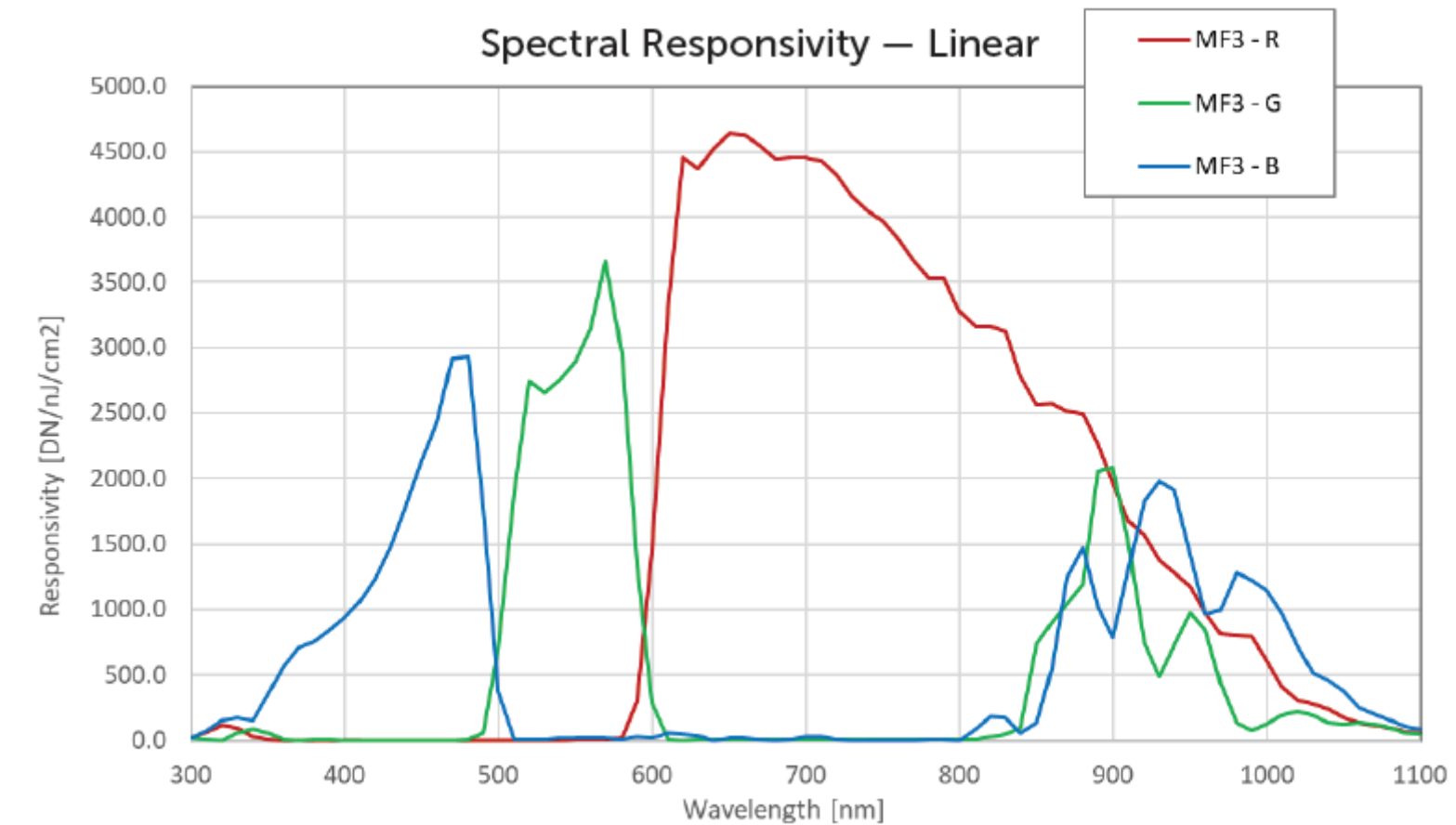
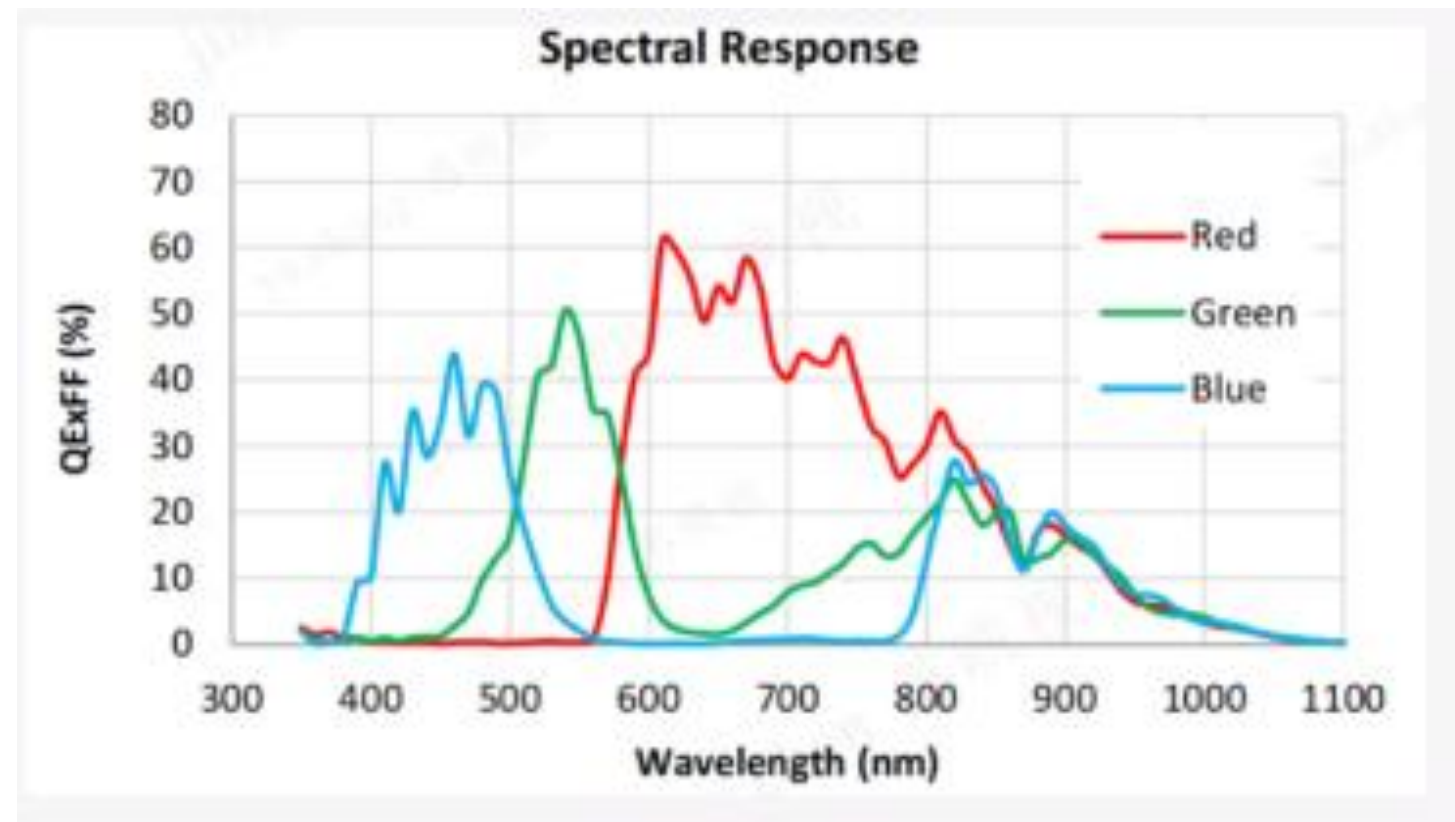

EMVA1288 Release 3.1 compliant - 8nm bandwidth, 10nm steps, Savitzky-Golay filtering: 3rd order, 5-point



<1,800dpi CIS Color 카메라>

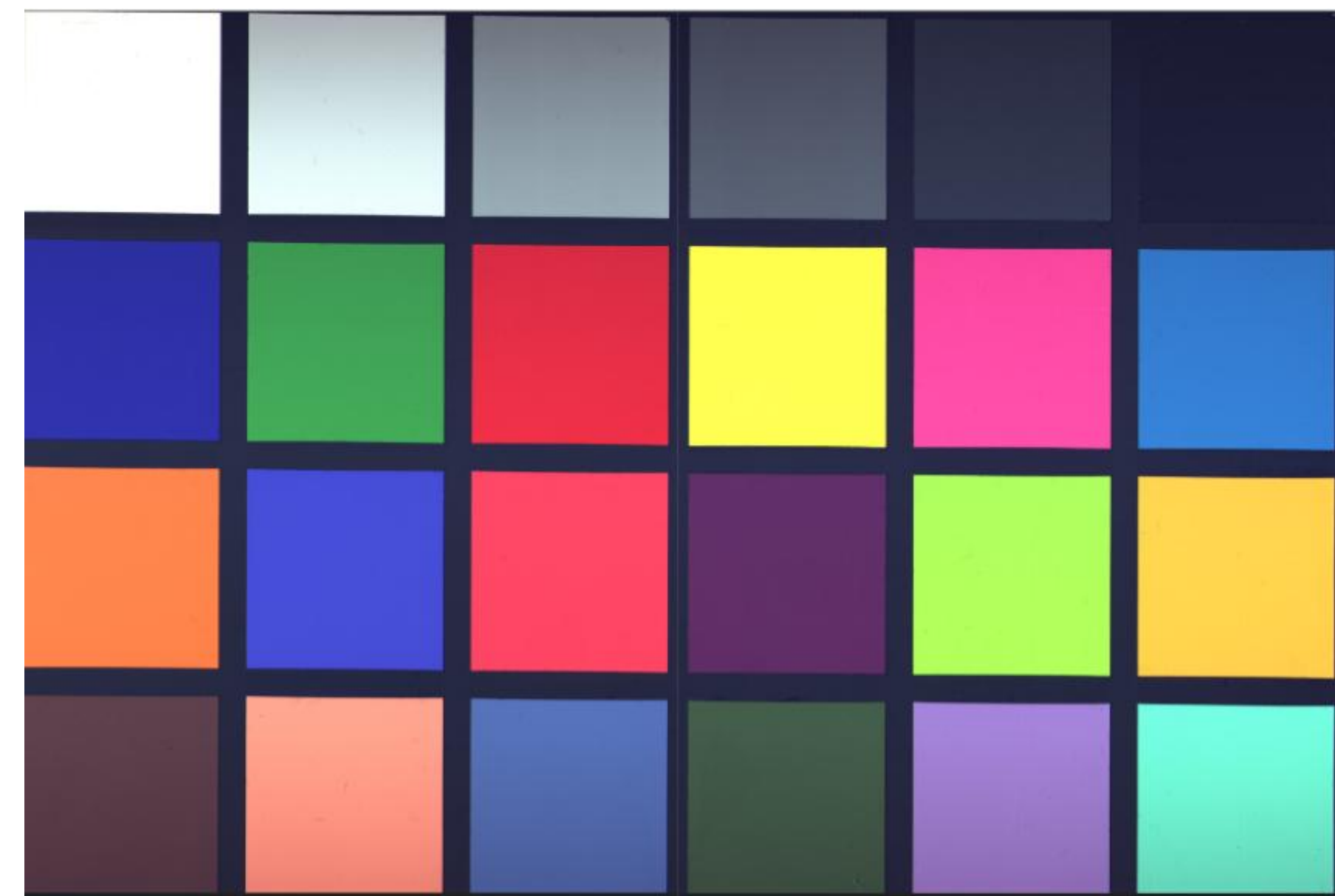

<3CMOS급의 Line Scan 카메라>

CIS Color vs 3CMOS Color Line Scan

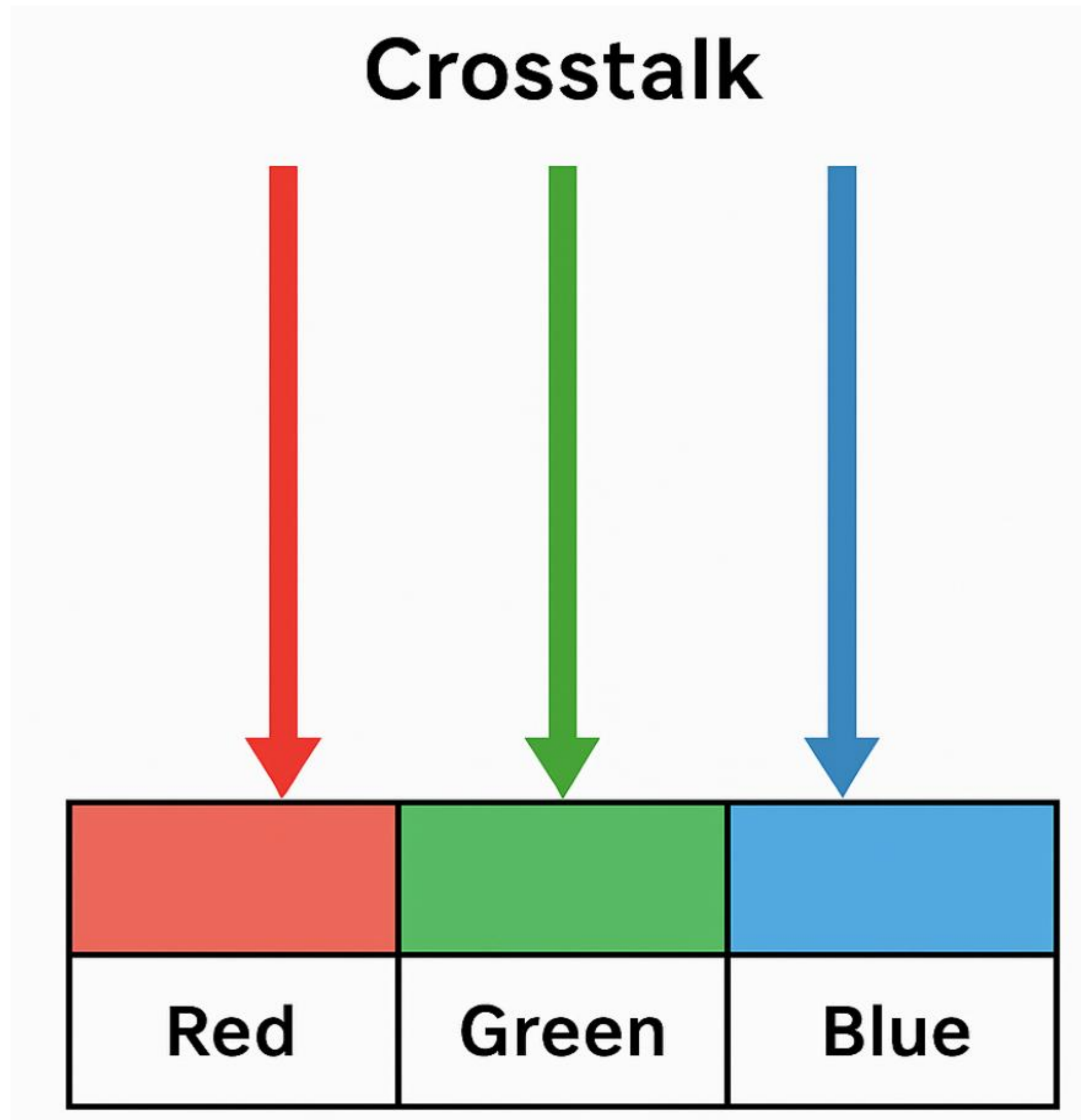

<Color CIS 카메라>

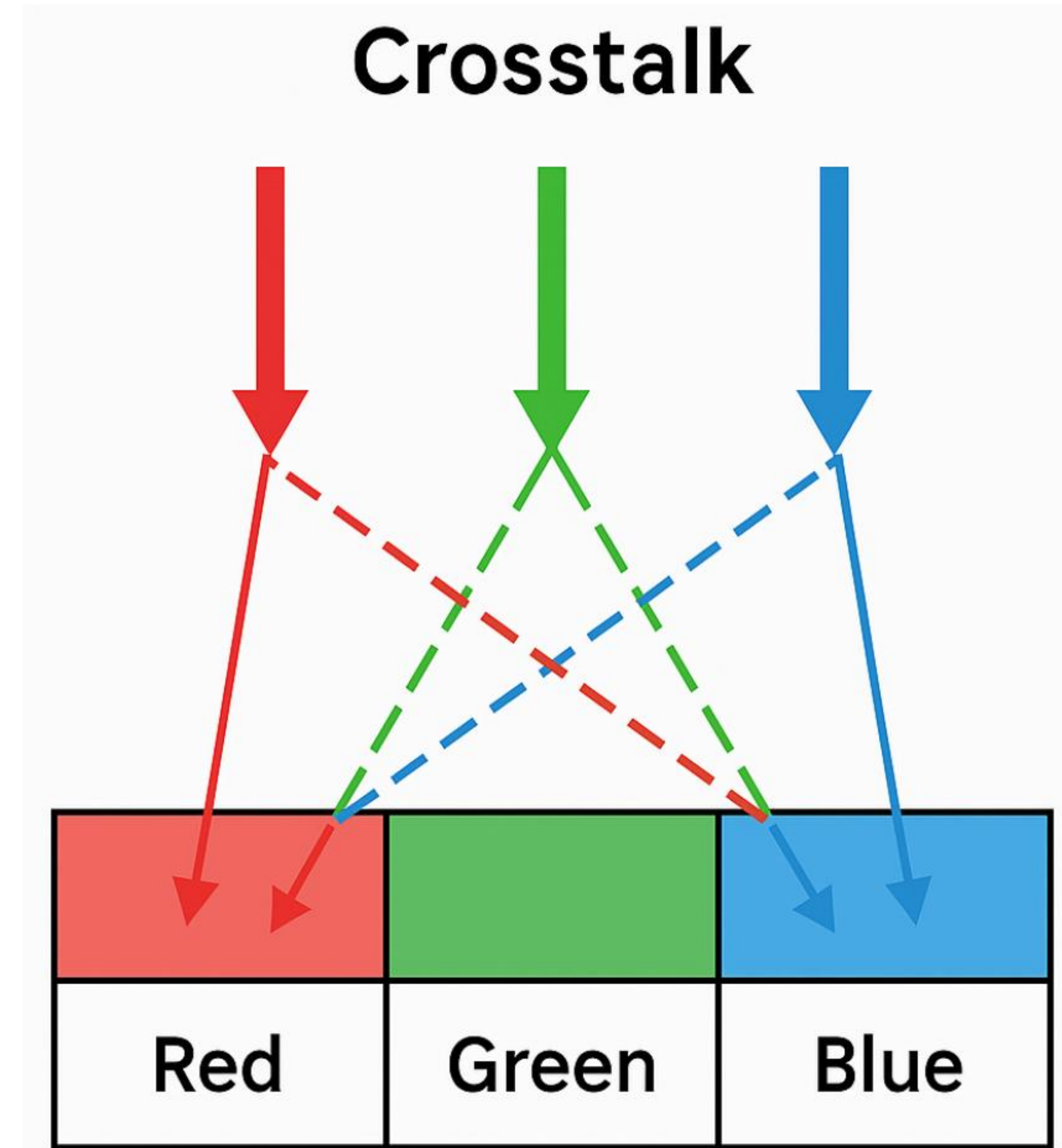

<일반CMOS 컬러라인스캔>

Color CIS카메라 Line-up

| 제품군 | WD | Resolution | Scan Width Range | Scan Speed Range | 2.5D 유무 |
|------|---------|----------------------|------------------|------------------|---------|
| CHVS | 15~50mm | 300/600 DPI | 69~1,453 mm | 66/110 KHz | X |
| LXM | 7~30mm | 900/1800/3600 DPI | 165~1,453 mm | 50 / 80 KHz | X |

**40GigE Color CIS 고속 모델 출시예정

05

2.5D Photometric Stereo CIS 소개



2.5D Photometric CIS 특징

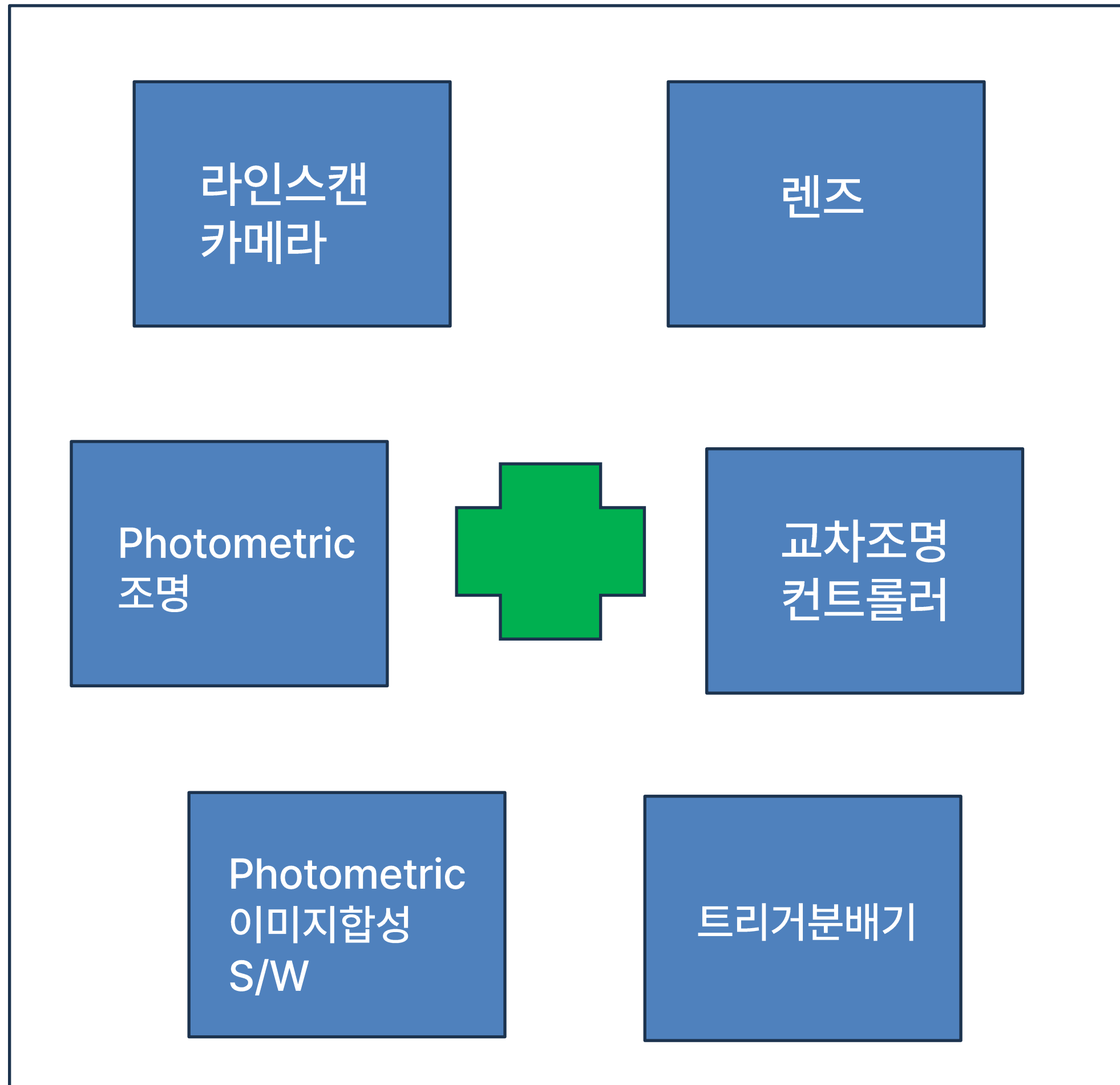

<2.5D Line Scan 구성품>

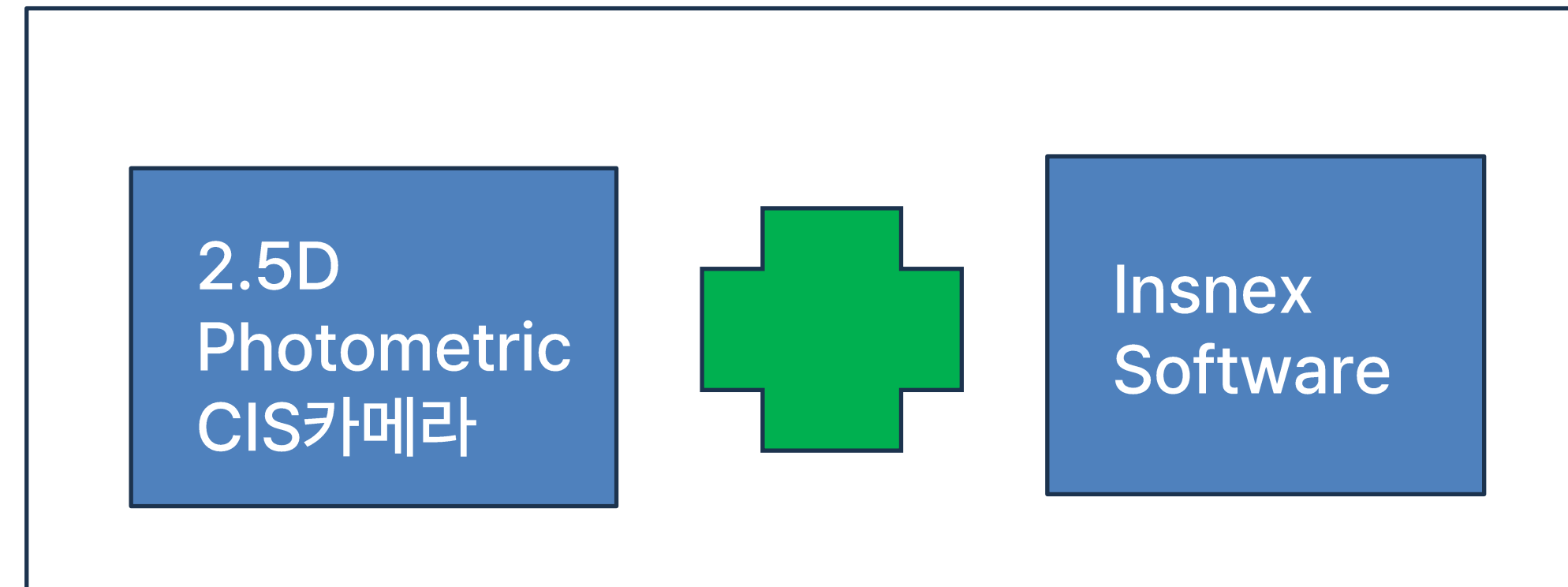
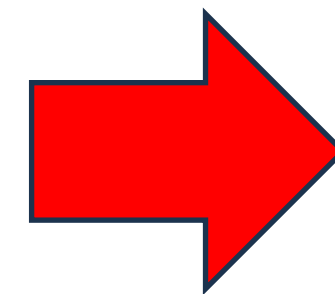

<2.5D Photometric CIS 구성품>

2.5D Photometric CIS 특징

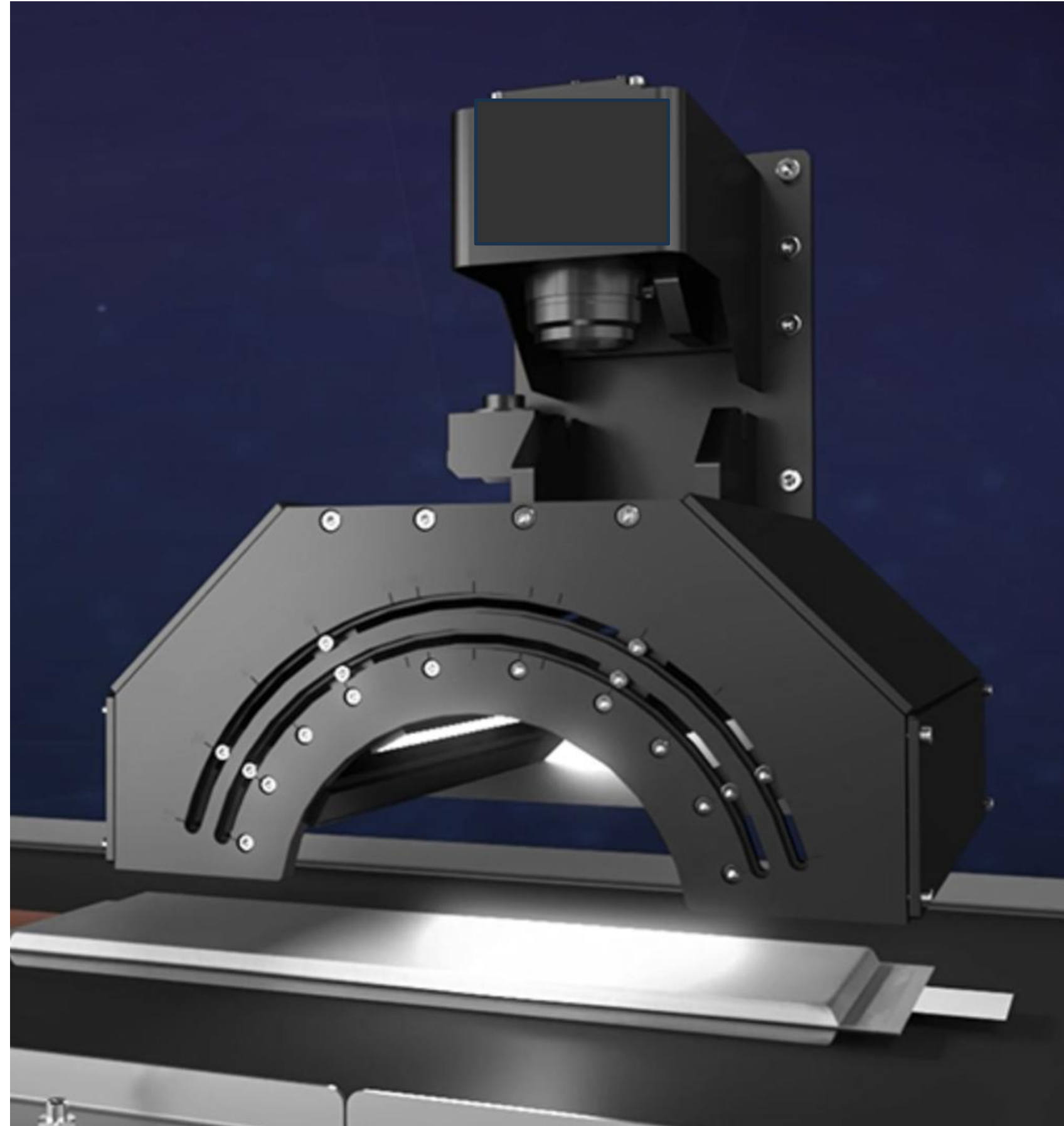

<Line Scan 2.5D Photometric>

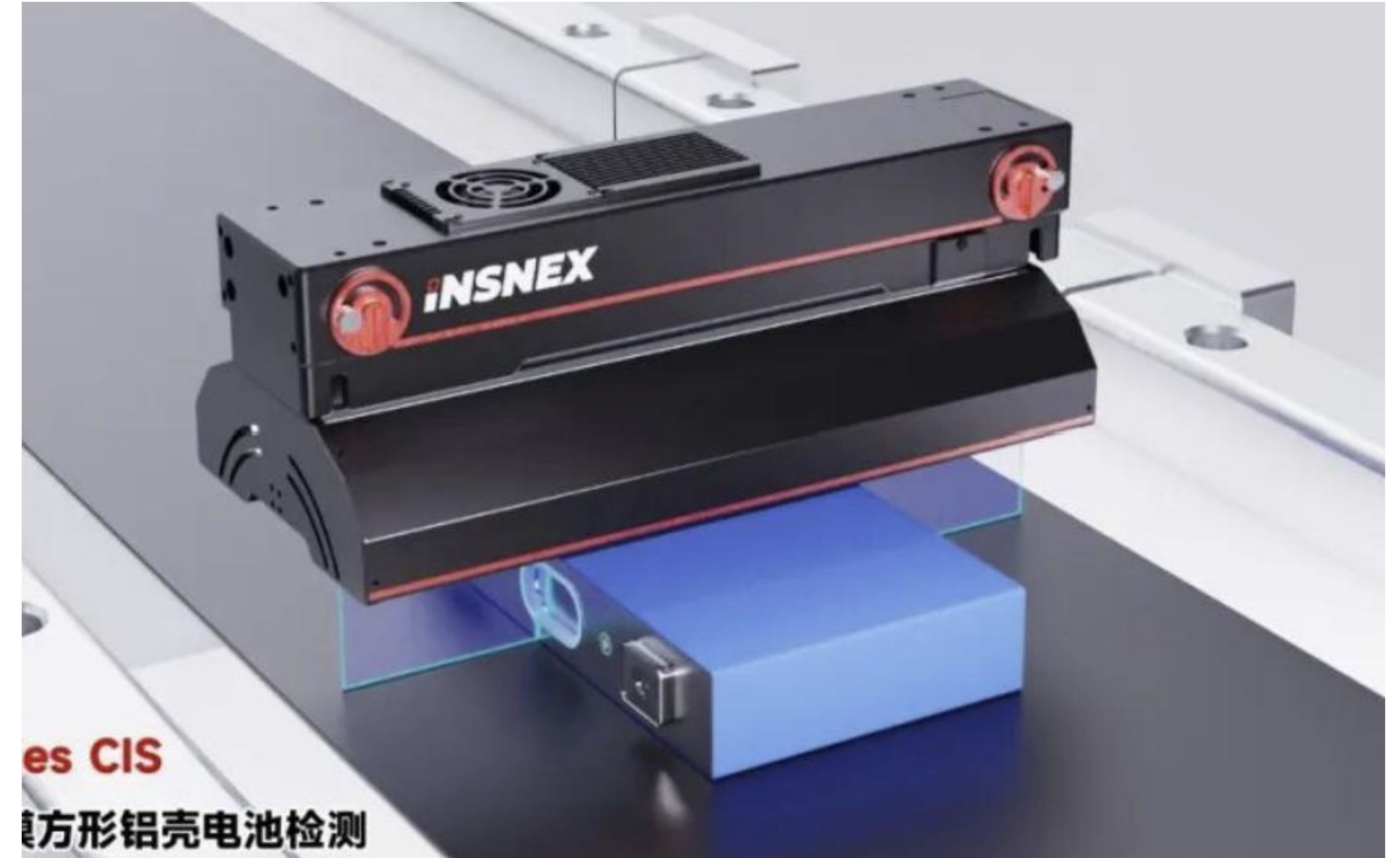
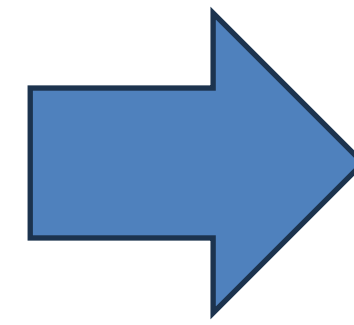

<2.5D Photometric CIS>

2.5D Photometric CIS 특징

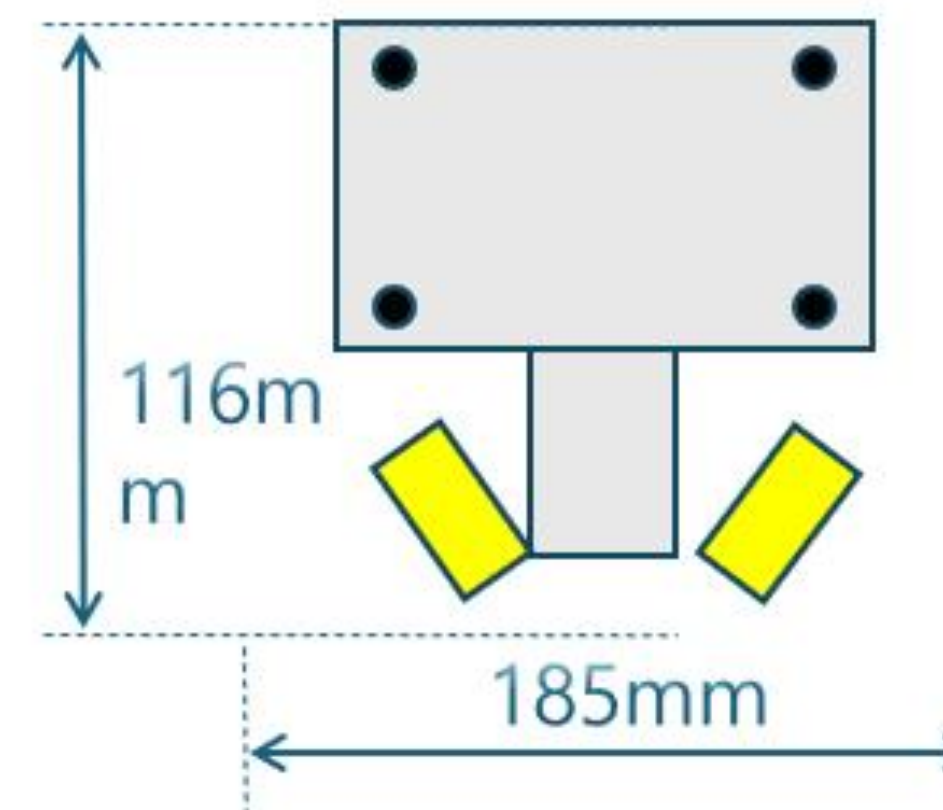
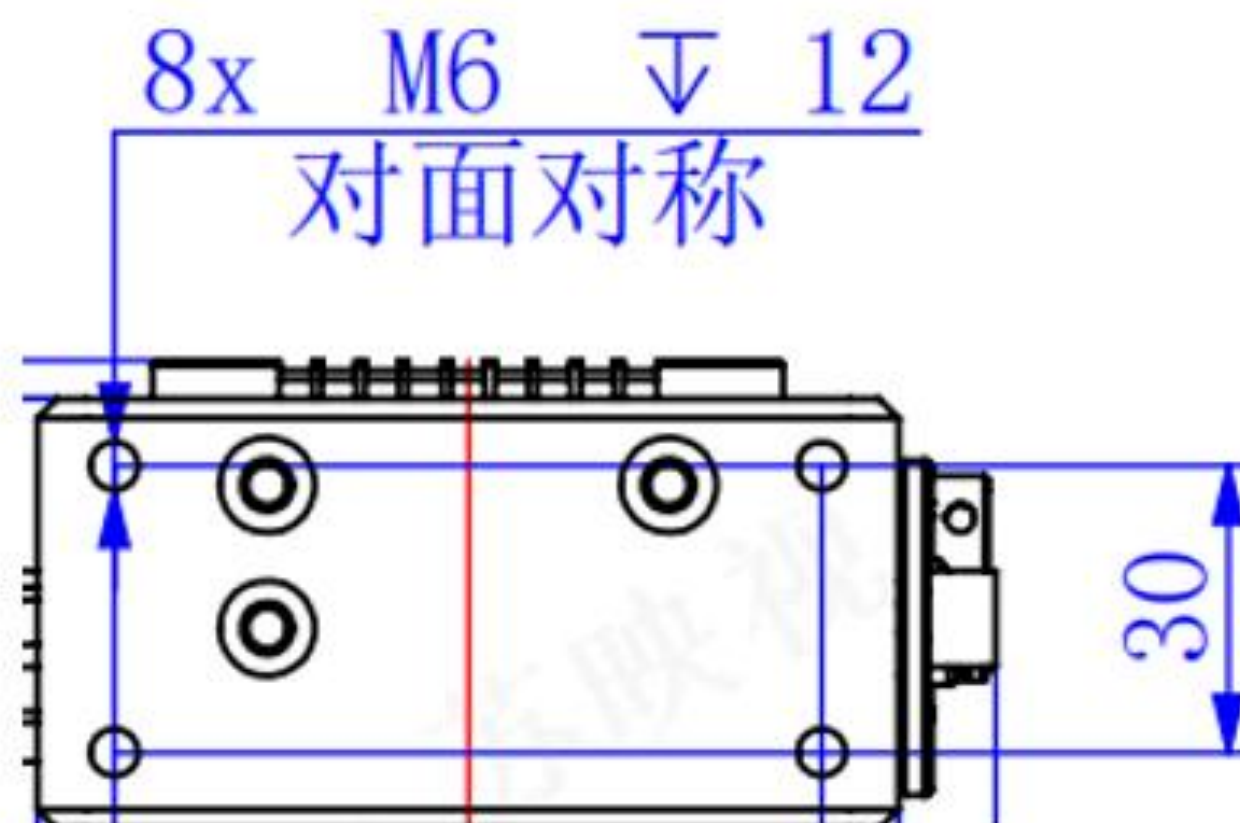
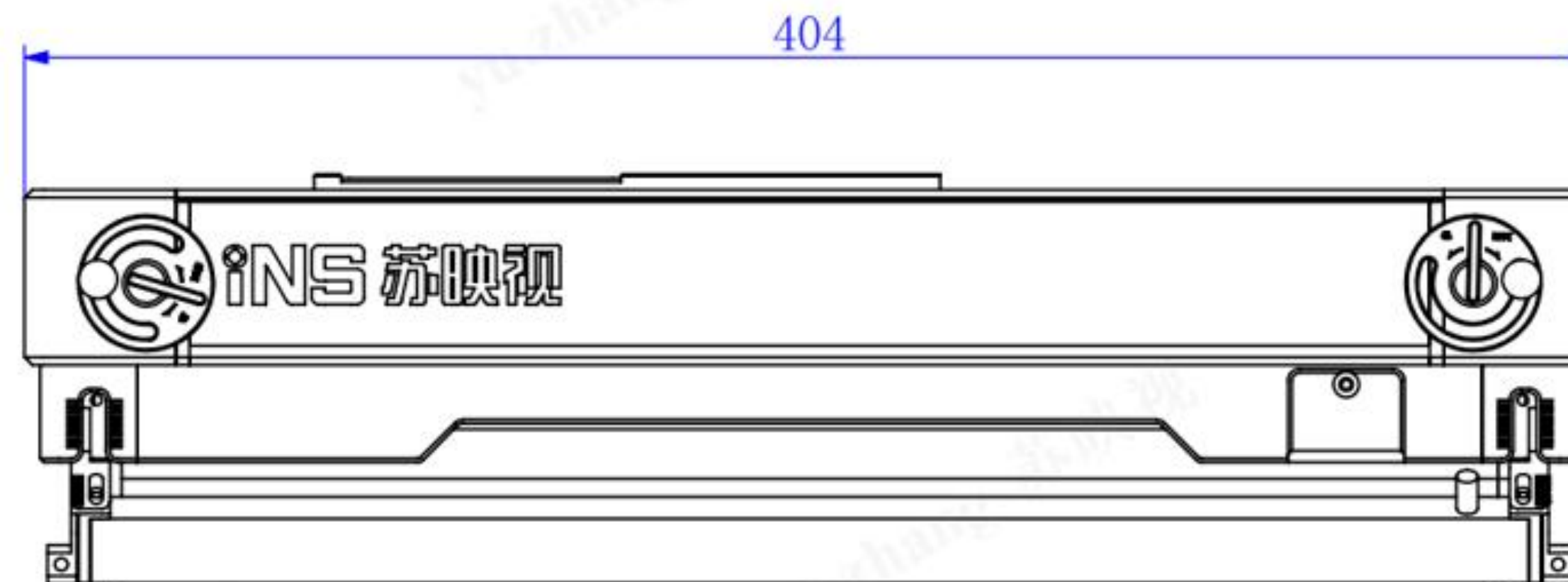
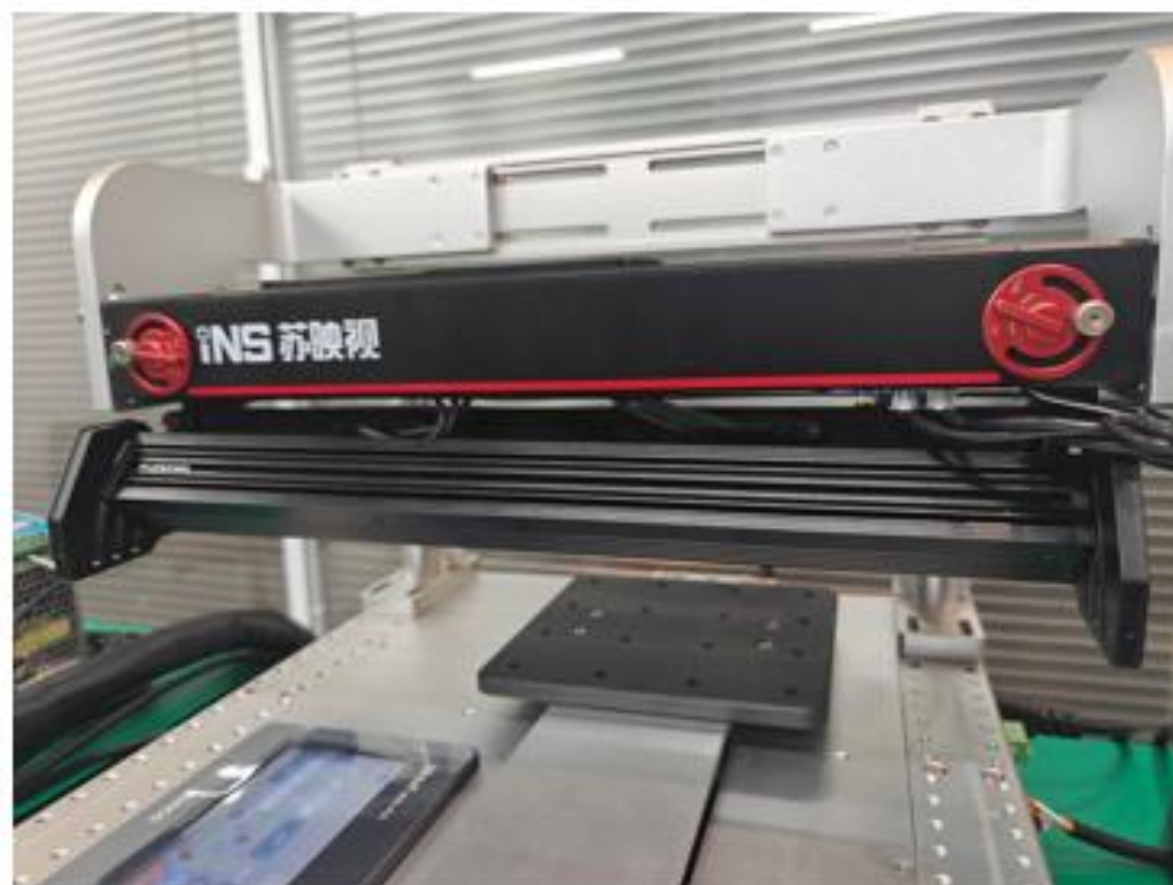

2.5D Photometric CIS 특징

| CIS 모델 | INS-LXM-328-10GM-18L |
|--------|----------------------|
| FOV | 328mm |
| DPI | 1800DPI |
| 해상도 | 14um |
| 스캔 속도 | 40kHz |
| 조명 수량 | 4CH or 5CH |

<조명각도>

- 1.45도
- 2.135도
- 3.225도
- 4.315도

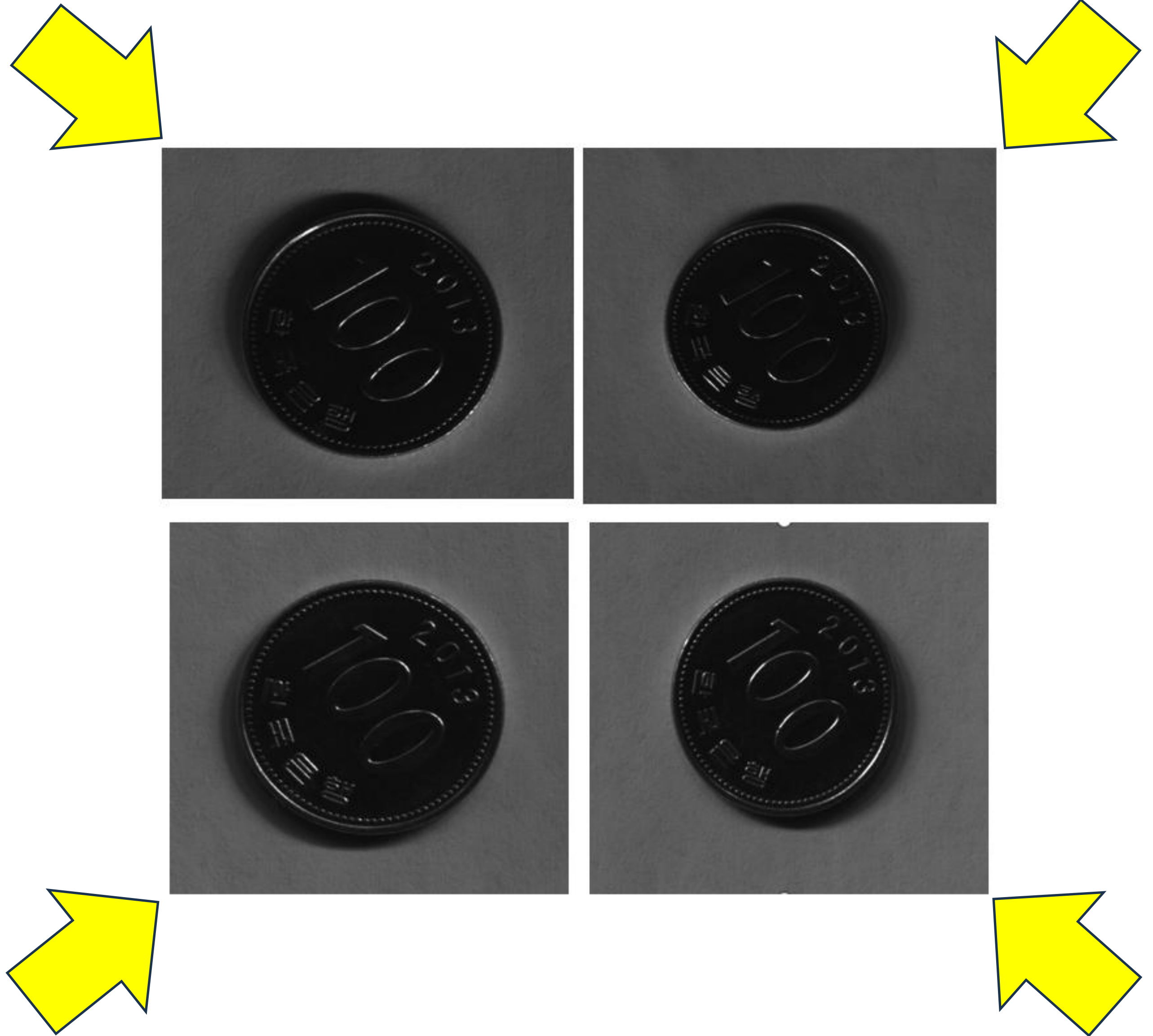

2.5D Photometric CIS 이미지 샘플



<테스트 조건>

- 노출시간: 12us
- 시스템속도: 20kHz
- 대응속도: 280mm/s (1,800dpi)
- 대응속도: 560mm/s (900dpi)

<테스트샘플: 배터리 파우치 셀>

2.5D Photometric CIS 이미지 샘플

파우치 셀 샘플 테스트 (에이지 스크래치)

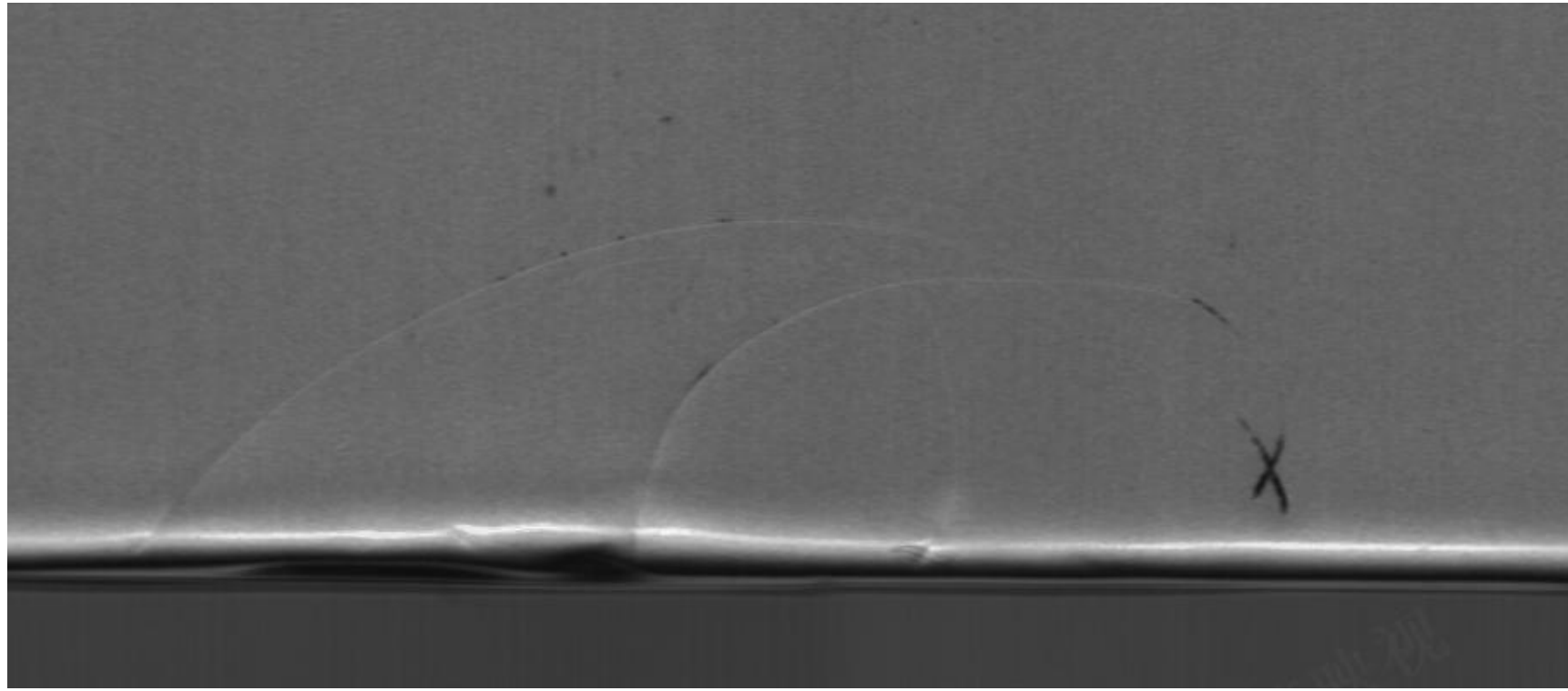

- Albedo -

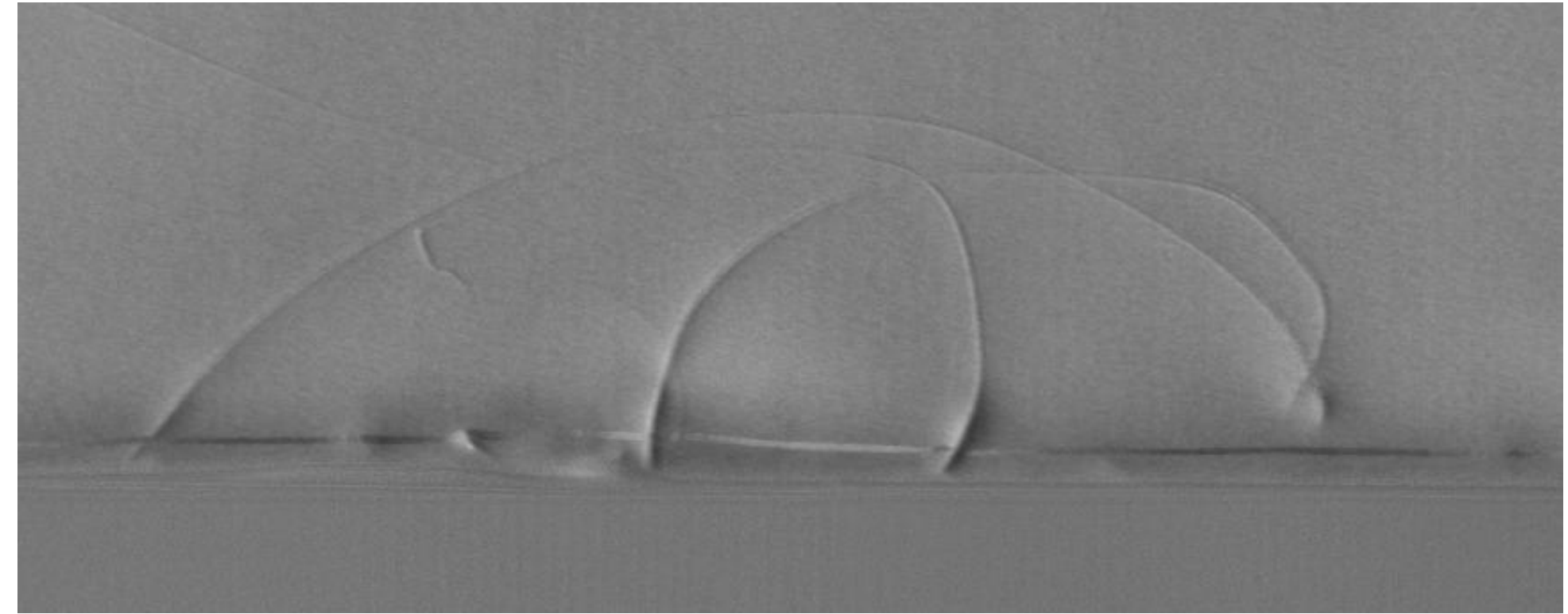

- Gradient1 -

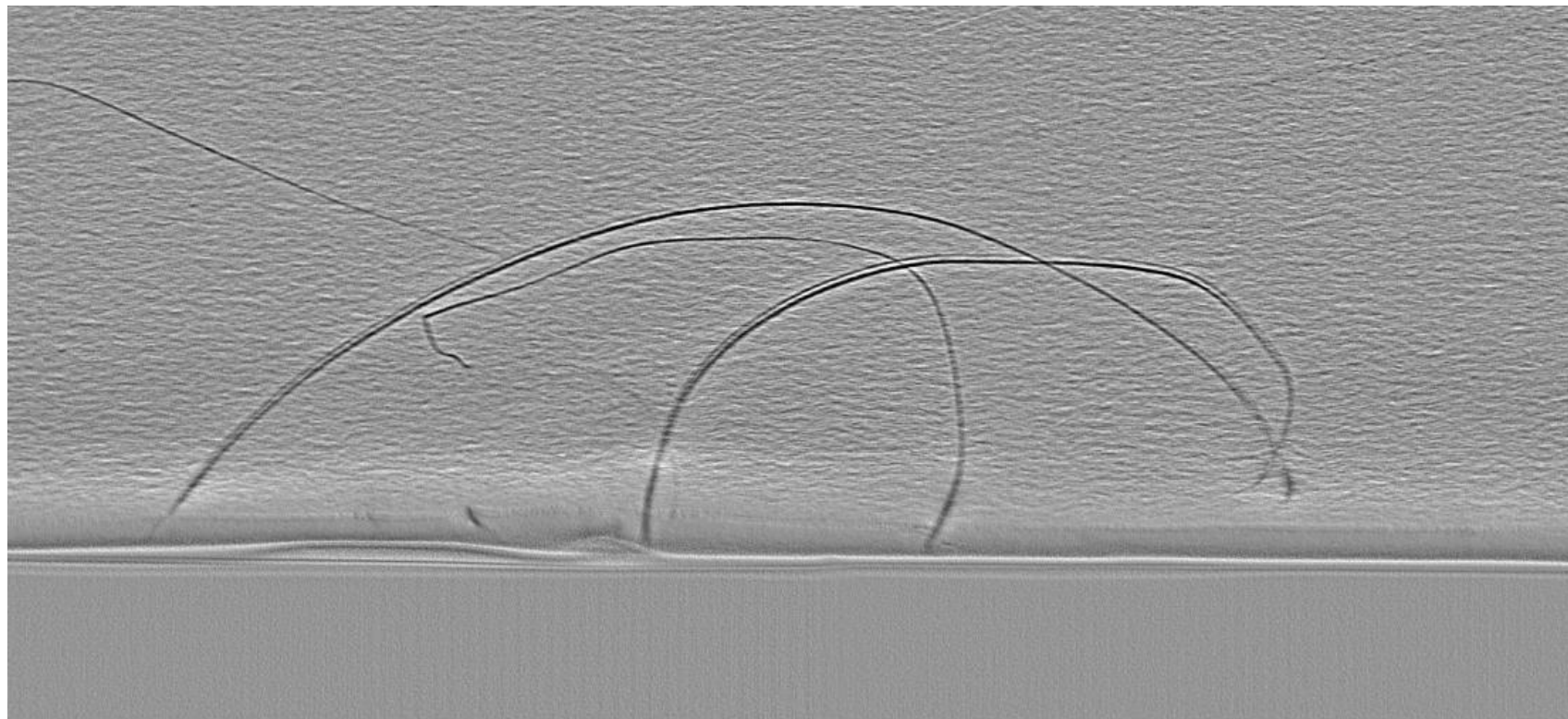

- Derivatemap -

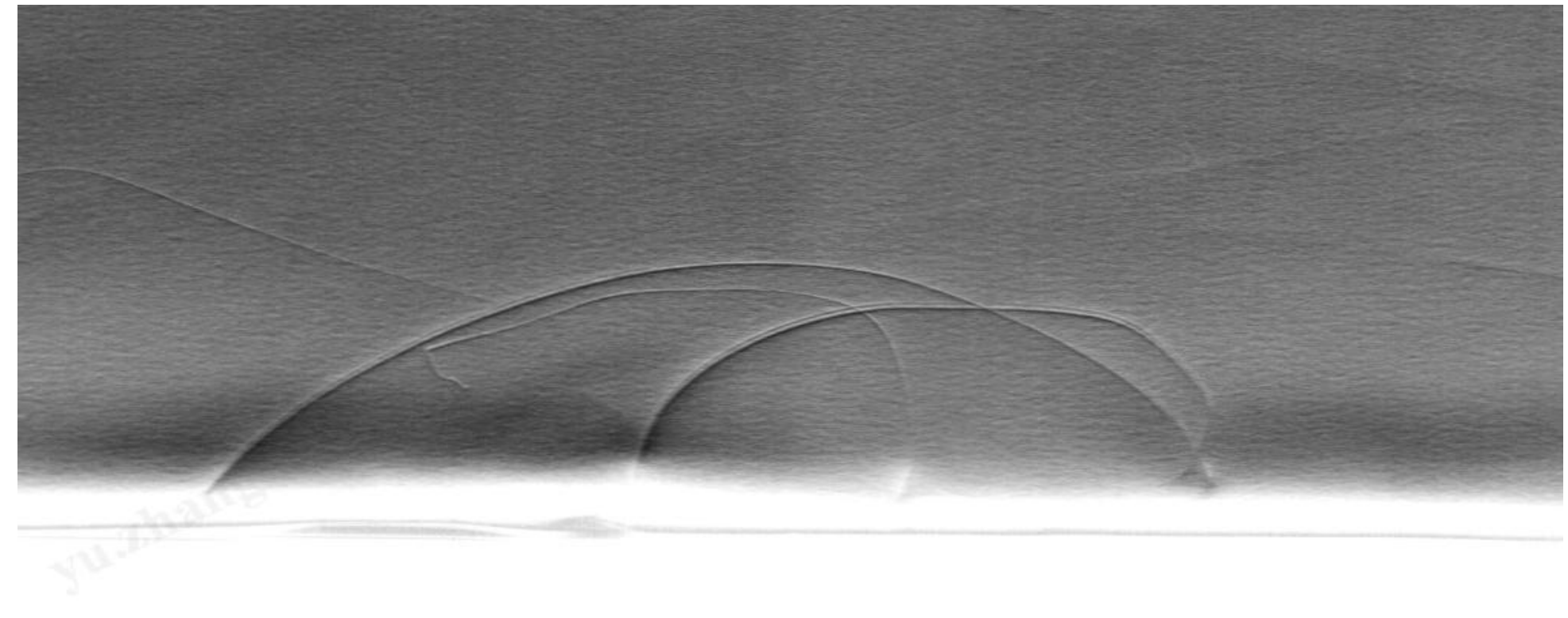

- Gradient2 -

2.5D Photometric CIS 이미지 샘플

파우치 셀 샘플 테스트 (에이지 찍힘)

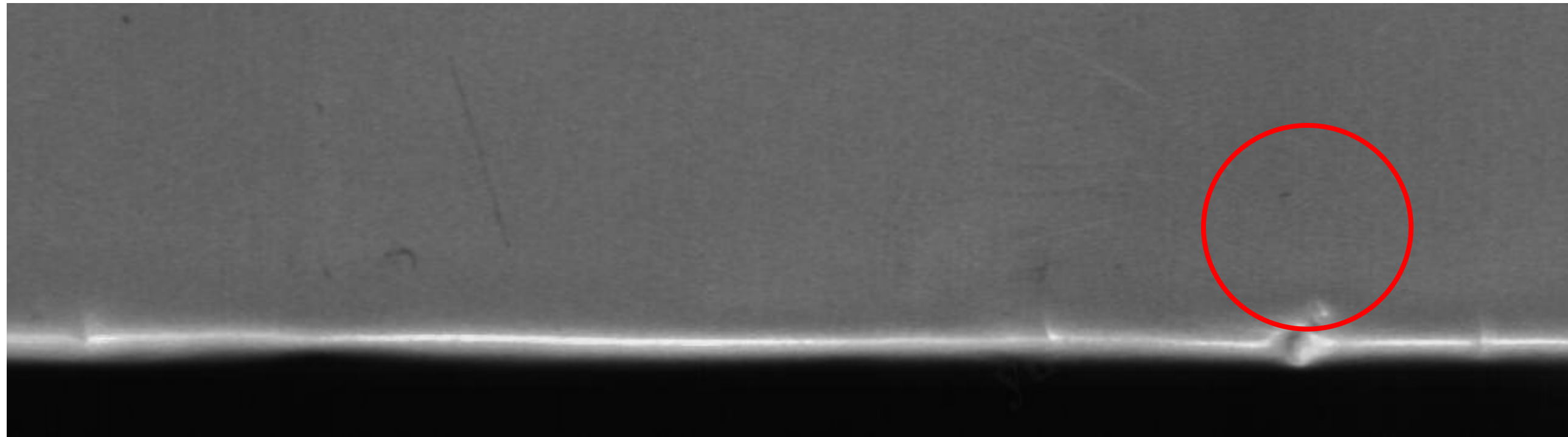

- Albedo -

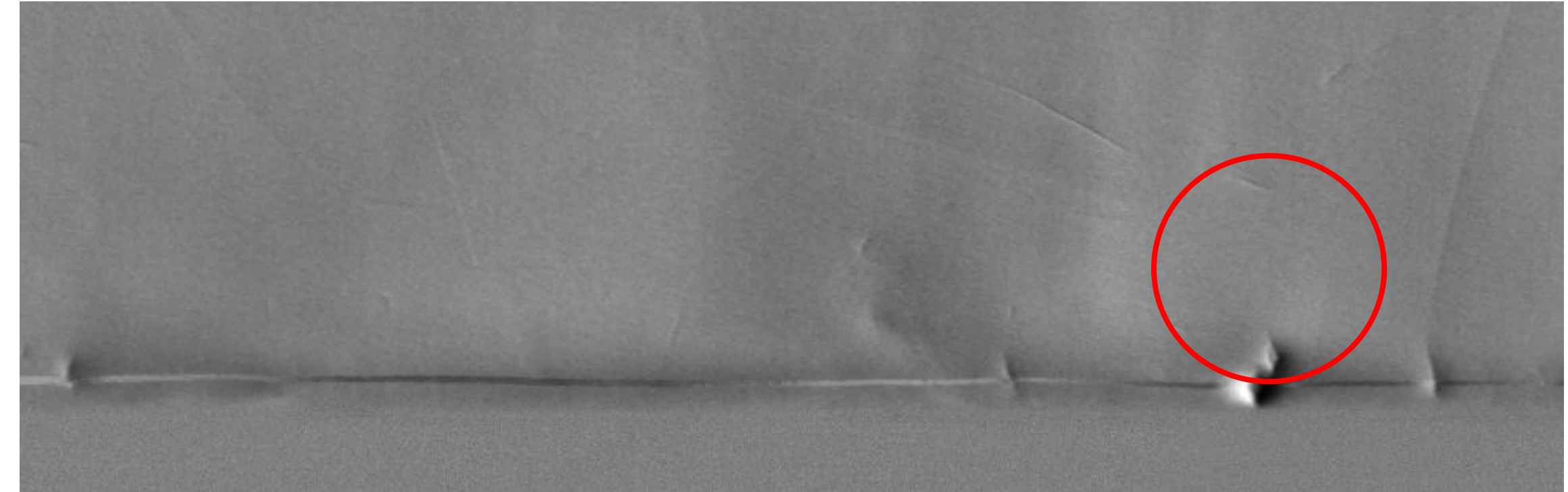

- Gradient1 -

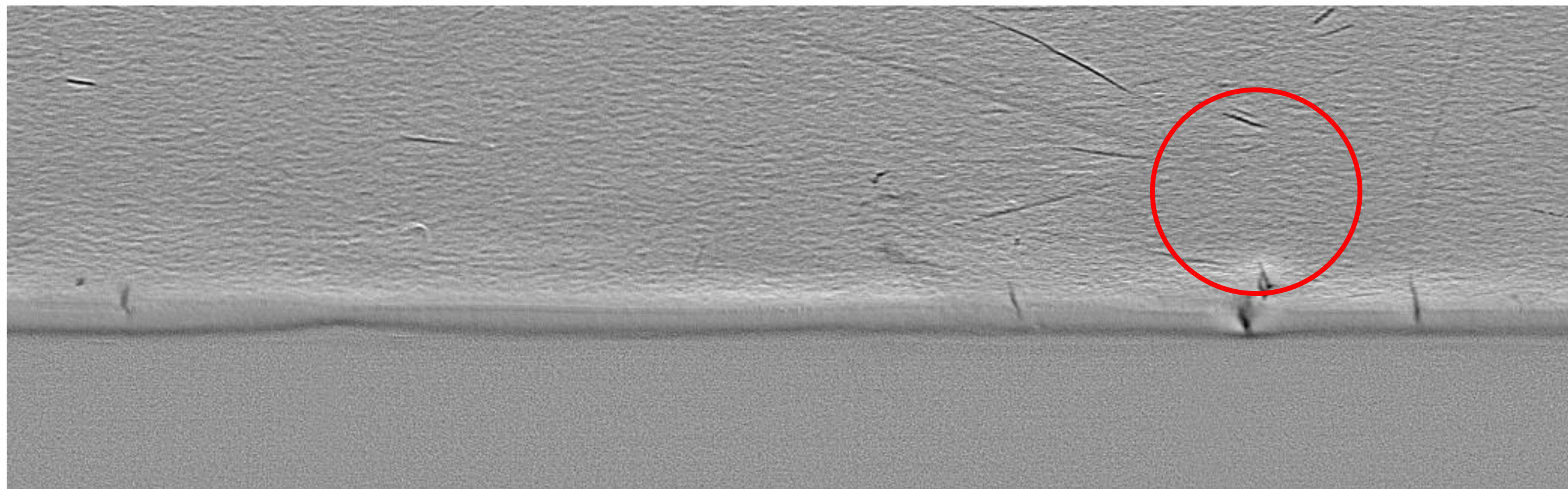

- Derivatemap -

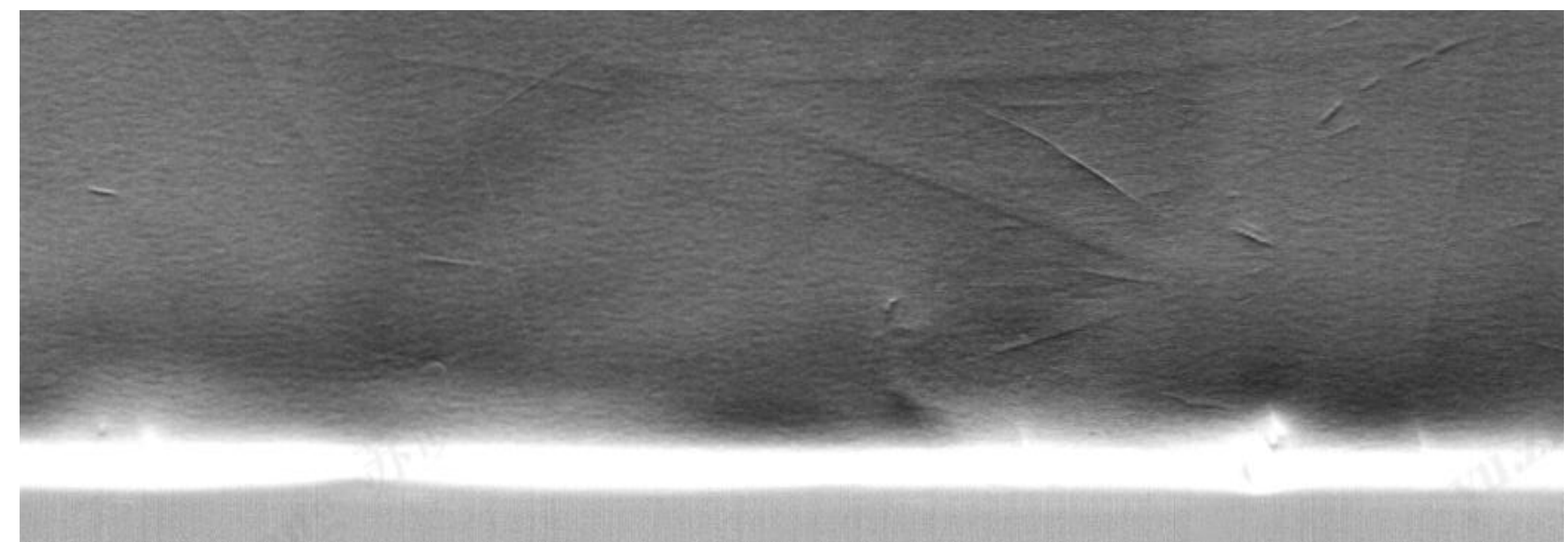

- Gradient2 -

2.5D Photometric CIS 이미지 샘플

파우치 셀 샘플 테스트 (크기별 **찍힘**)



- Albedo -

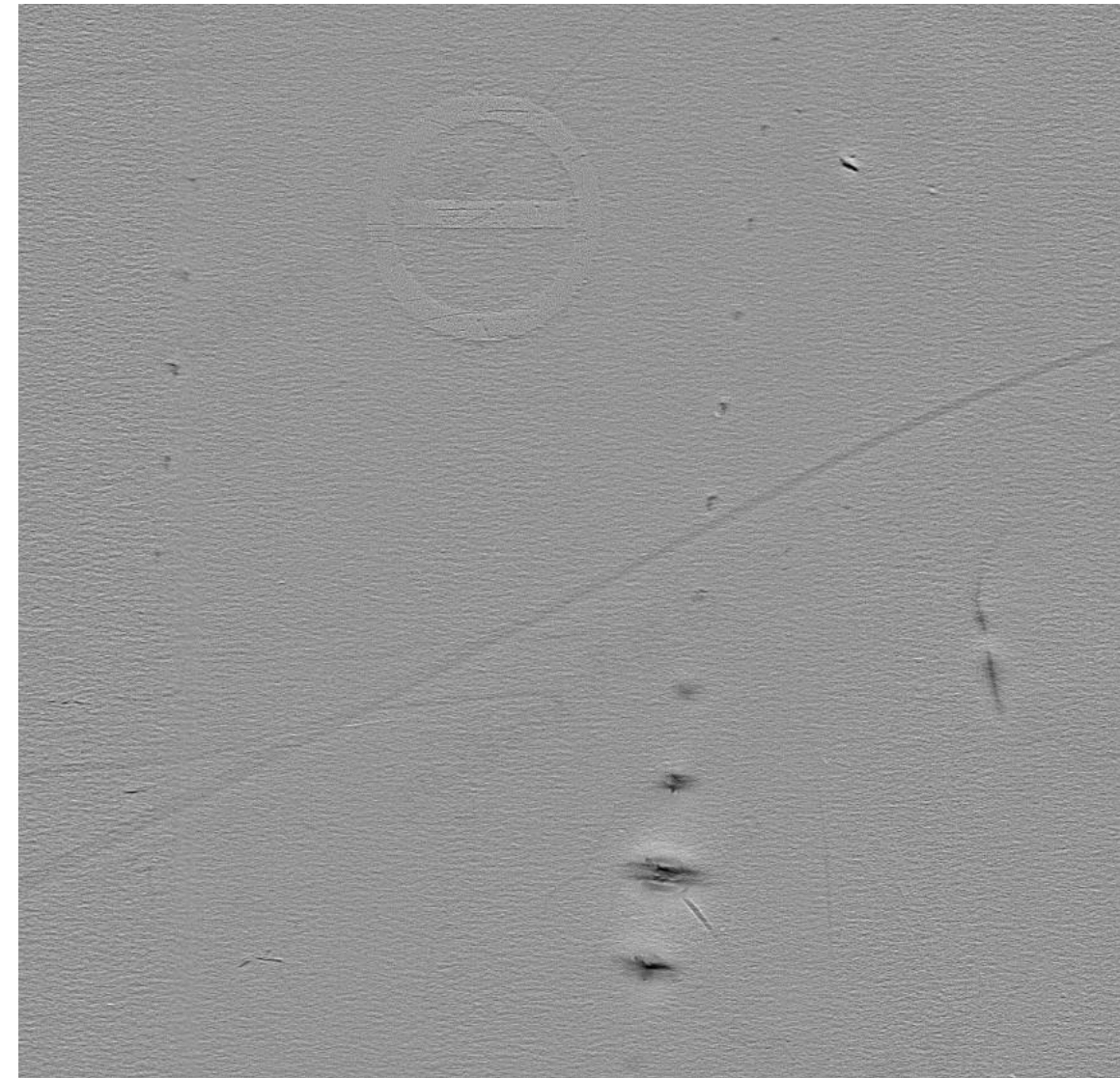

- Derivatemap -

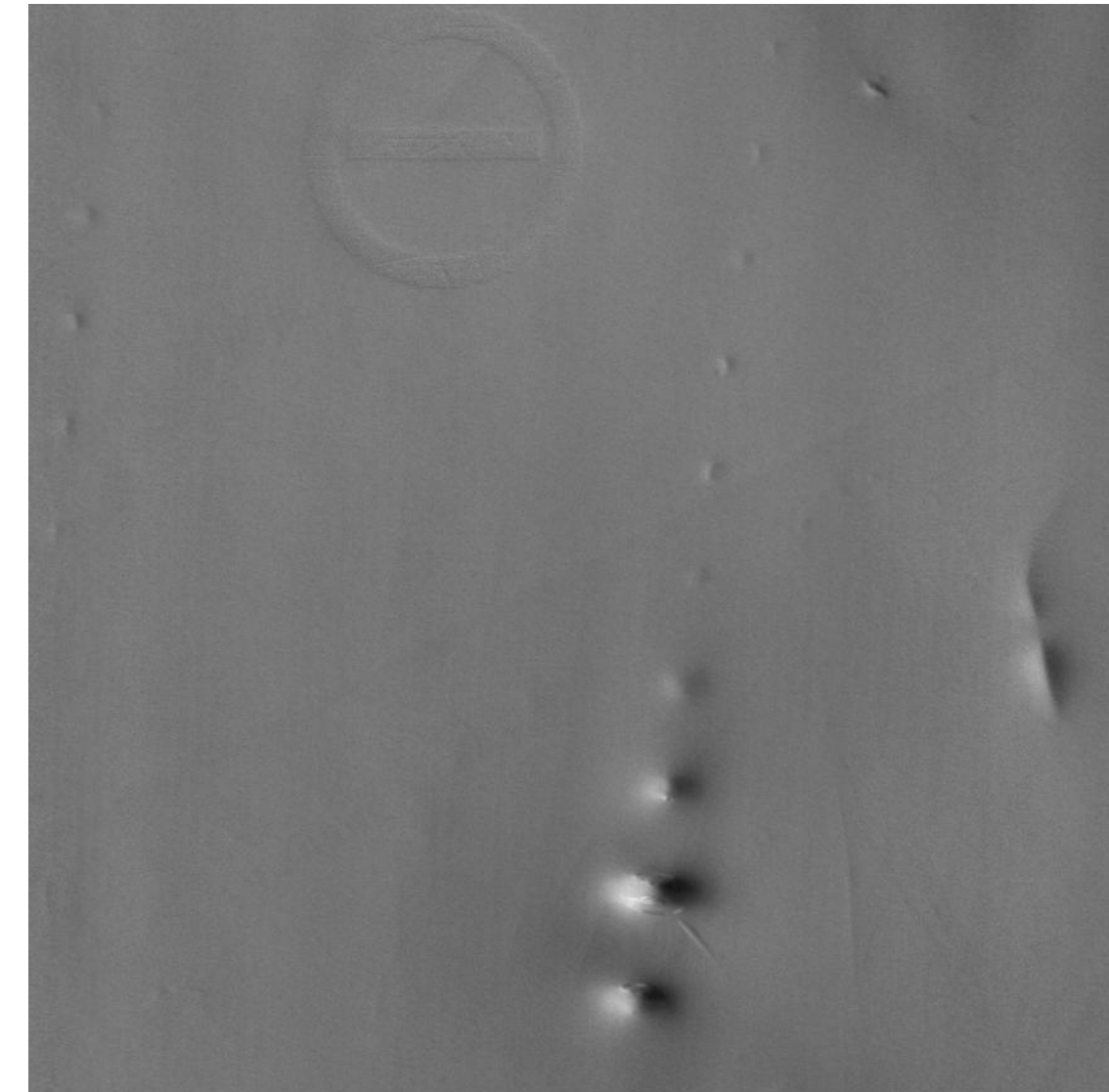

- Gradient1 -

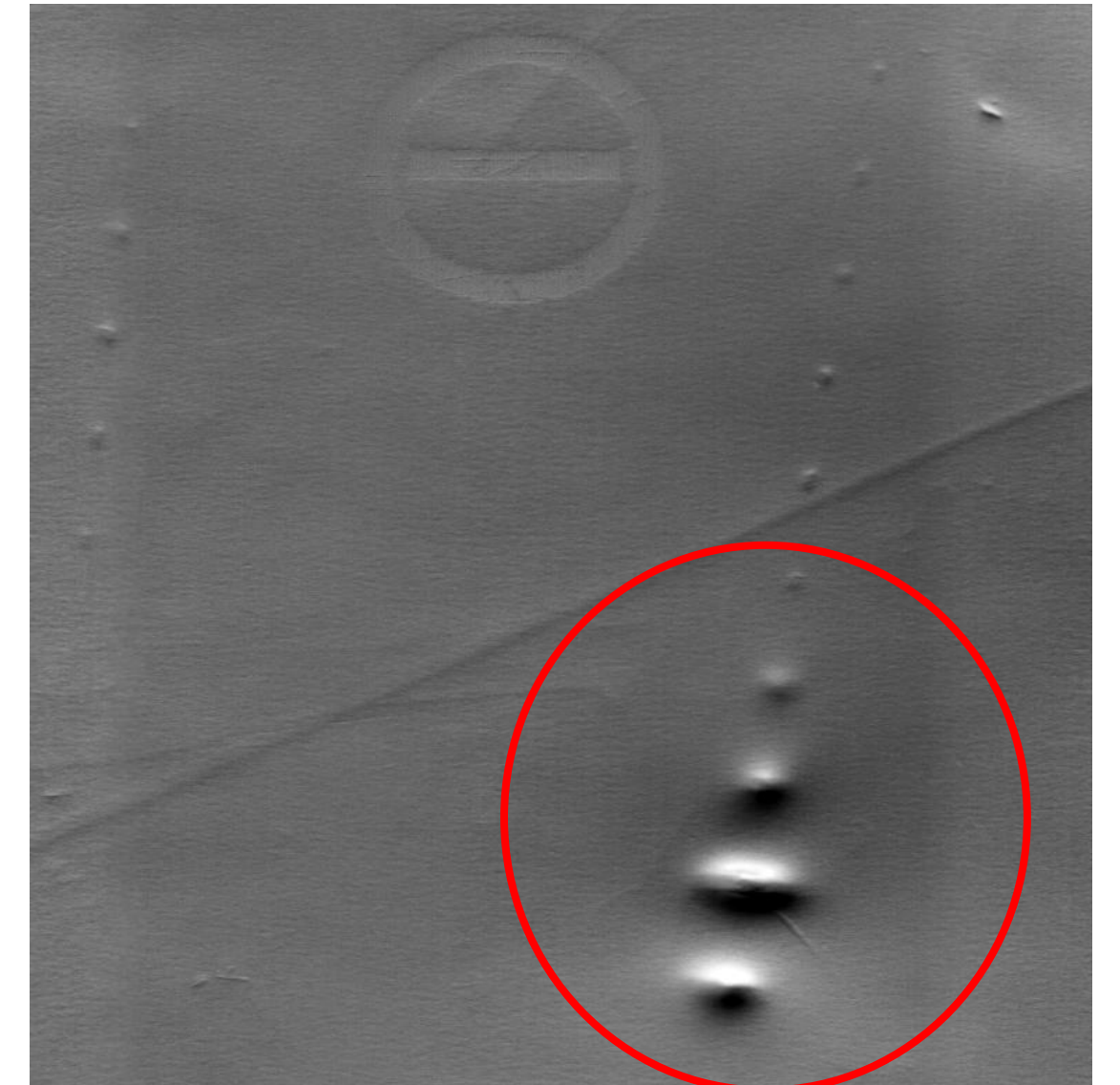

- Gradient2 -

06

Application #1 : PCB Inspection

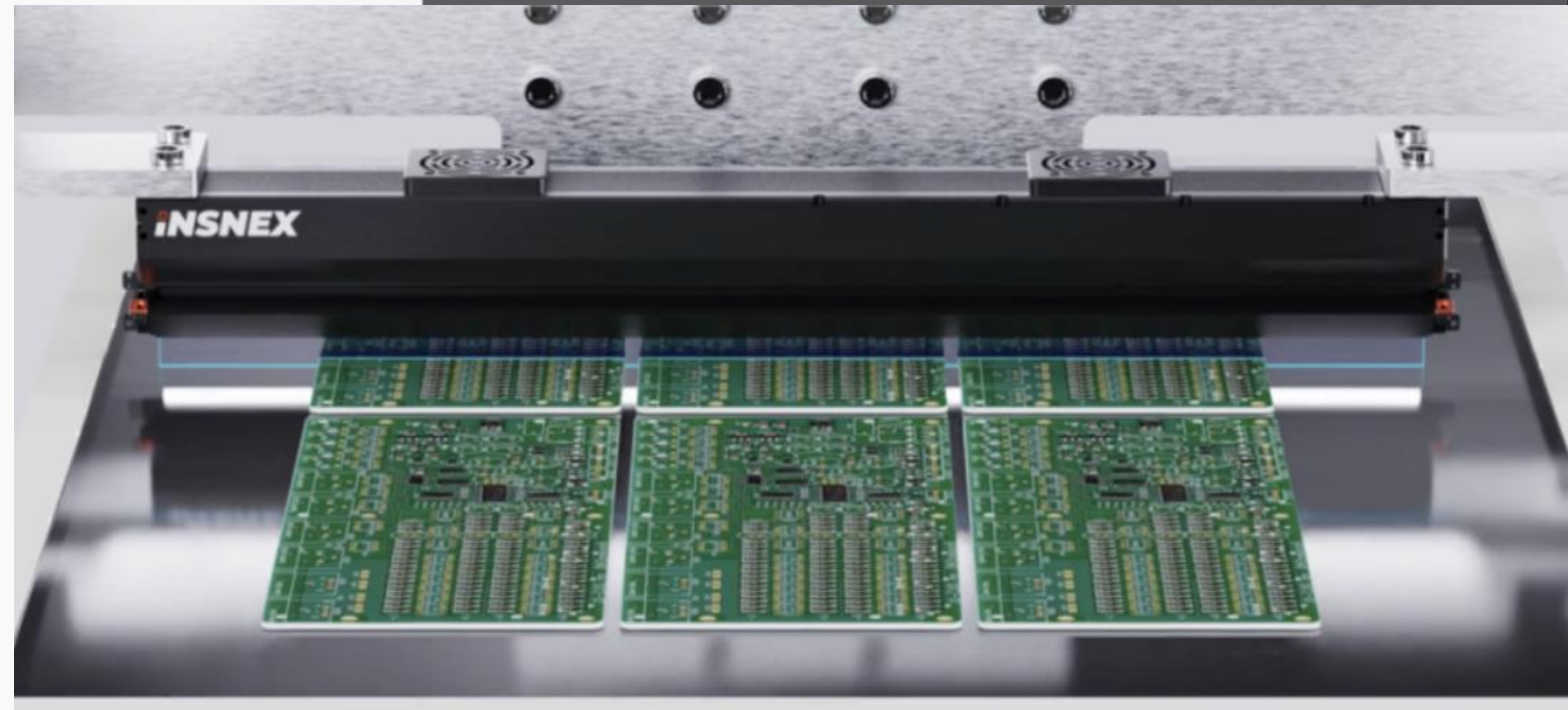

PCB 전용 CIS 광학 솔루션 (PCB용 동축조명)



CIS

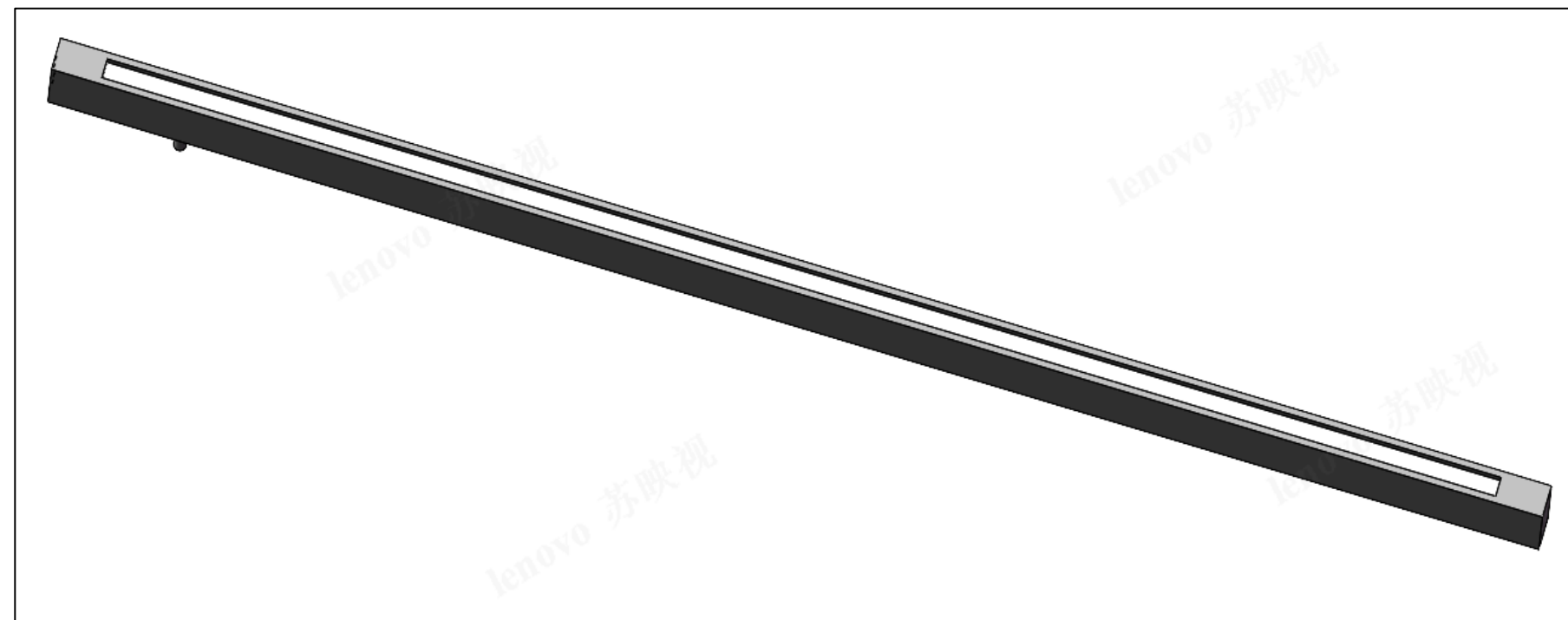
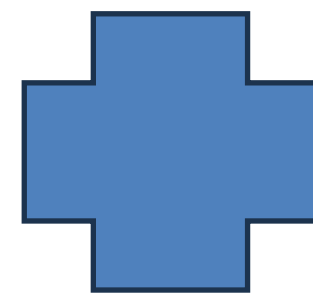

Light



<PCB 전용 동축 CIS 조명>

PCB 전용 CIS 광학 솔루션 (PCB 이미지 비교)

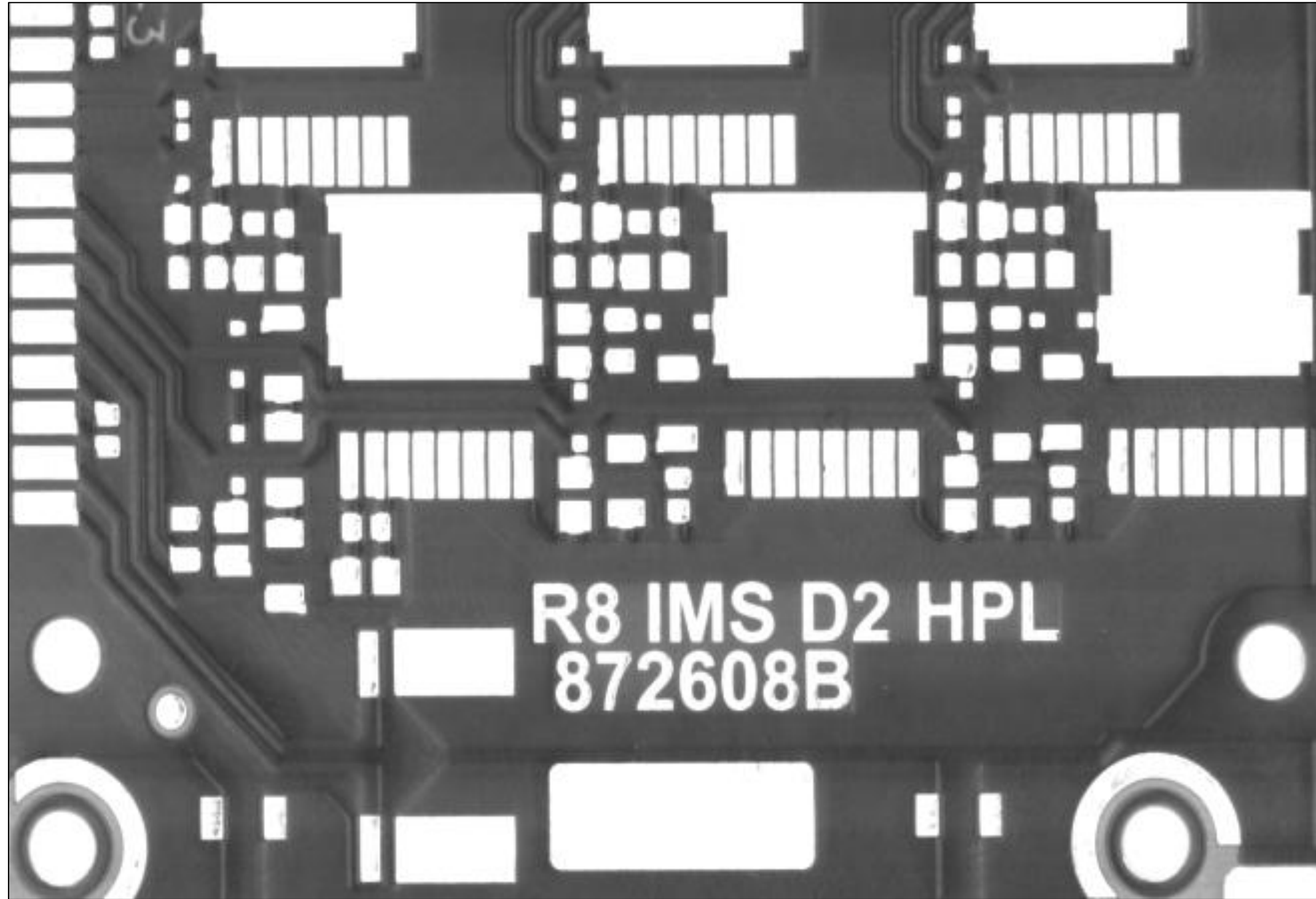

< PCB 전용 동축조명 사용시 >

- 선명한 문자 가독성 확보
- 금속부의 밝은 이미지 구현
- 금속부 코팅층의 뚜렷한 명암 대비

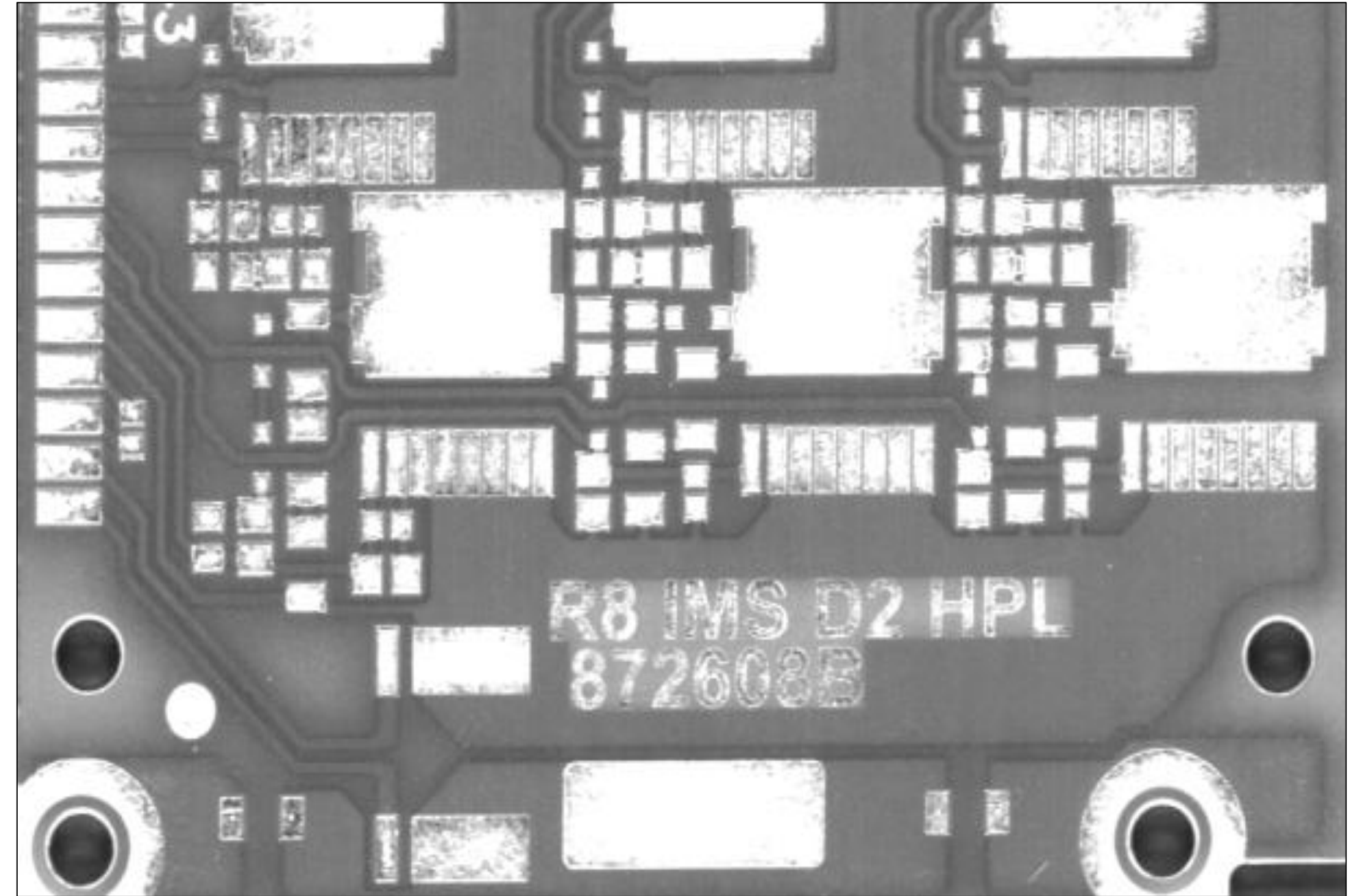

< 일반 CIS 동축조명 사용시 >

| 촬영조건 | |
|--------|-----------------------------------|
| CIS | 3,600DPI(7um), Mono, 656mm, 40kHz |
| Lights | PCB Coaxial Light for CIS |

PCB 전용 CIS 광학 솔루션 (PCB 샘플이미지)

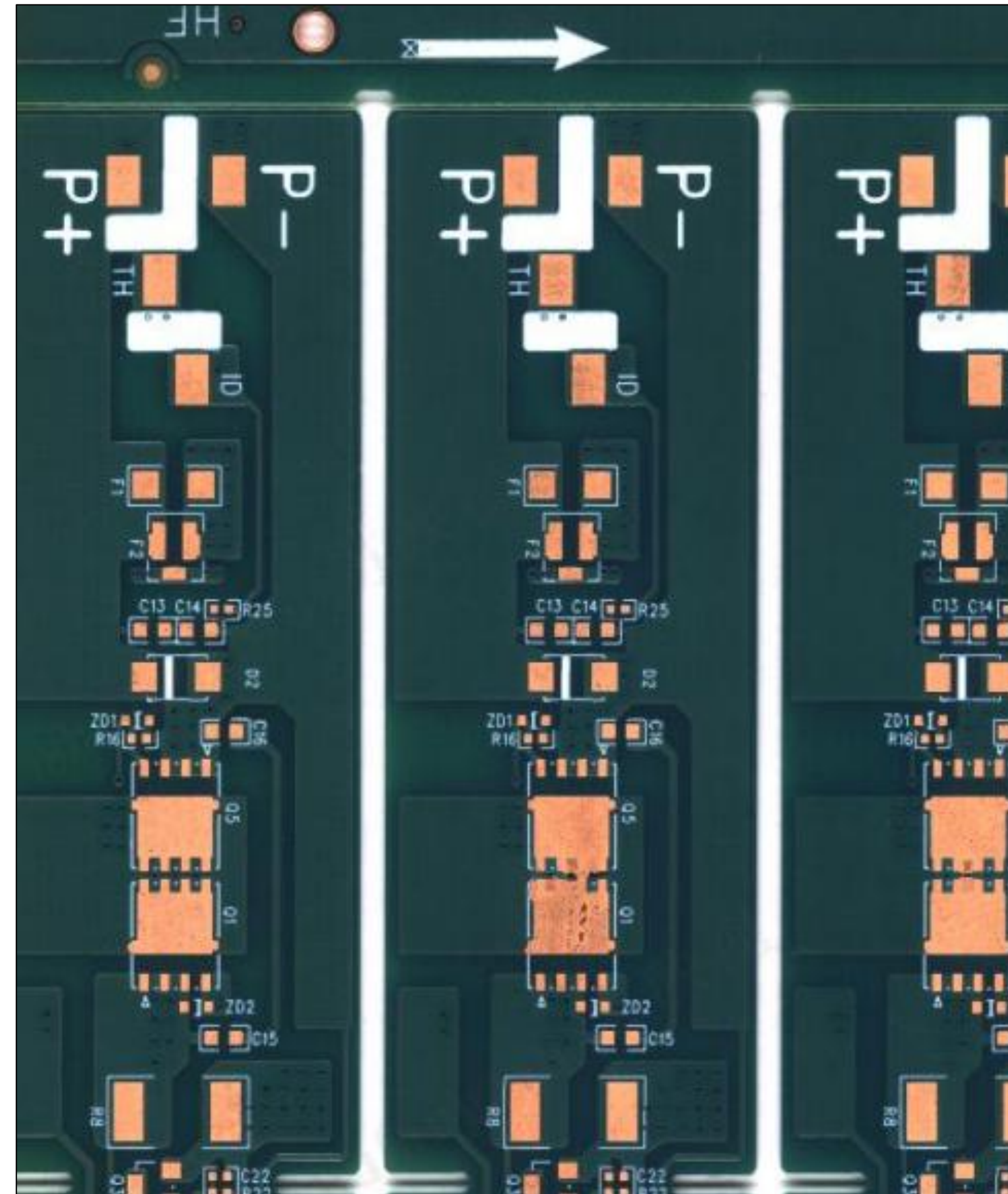
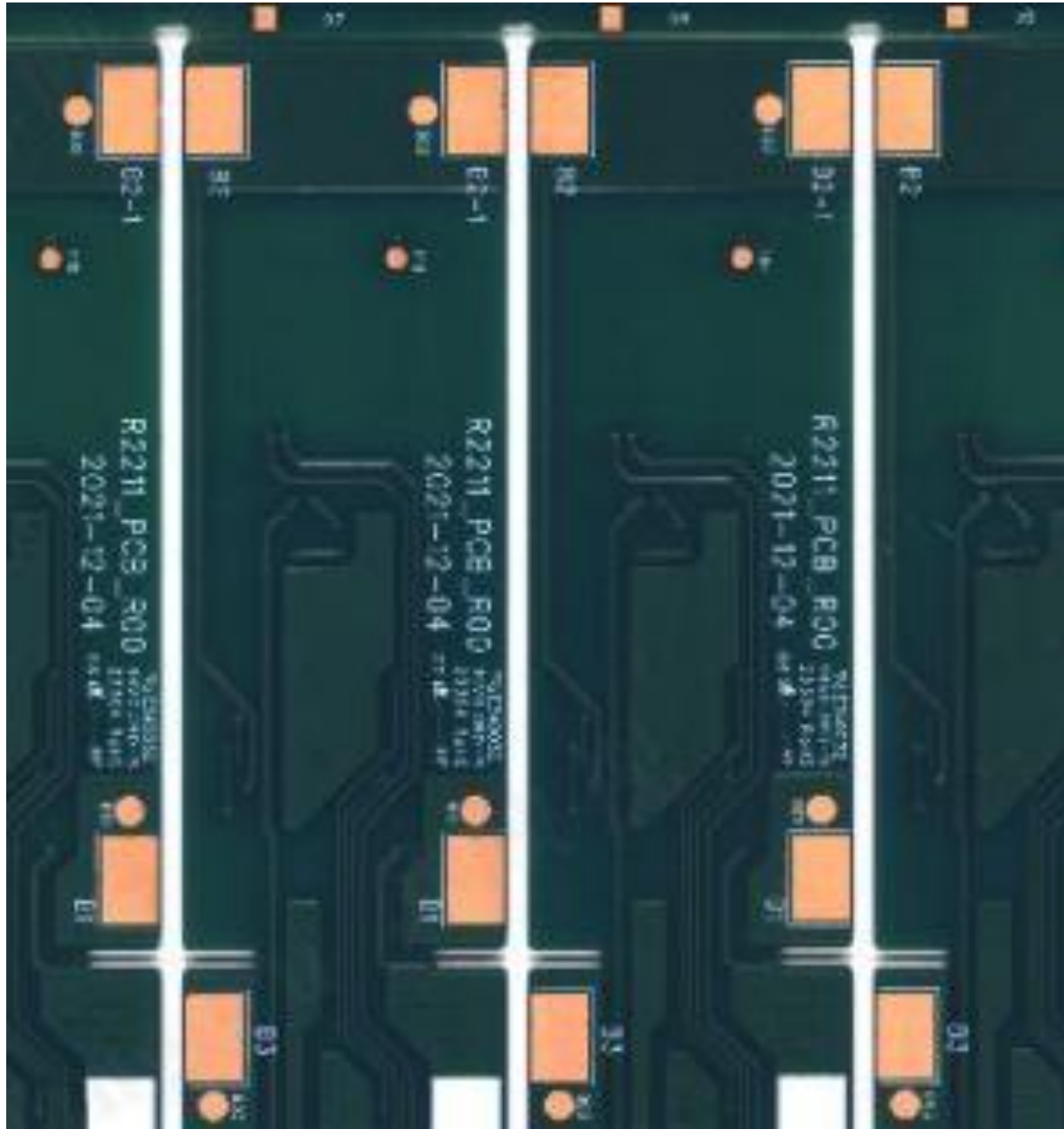

| | |
|-------|-----------------------------|
| CIS | 1,800dpi, Color, FOV: 328mm |
| Light | CIS용 일반 내부 조명 사용 |

PCB 전용 CIS 광학 솔루션 (PCB Tray 샘플이미지)

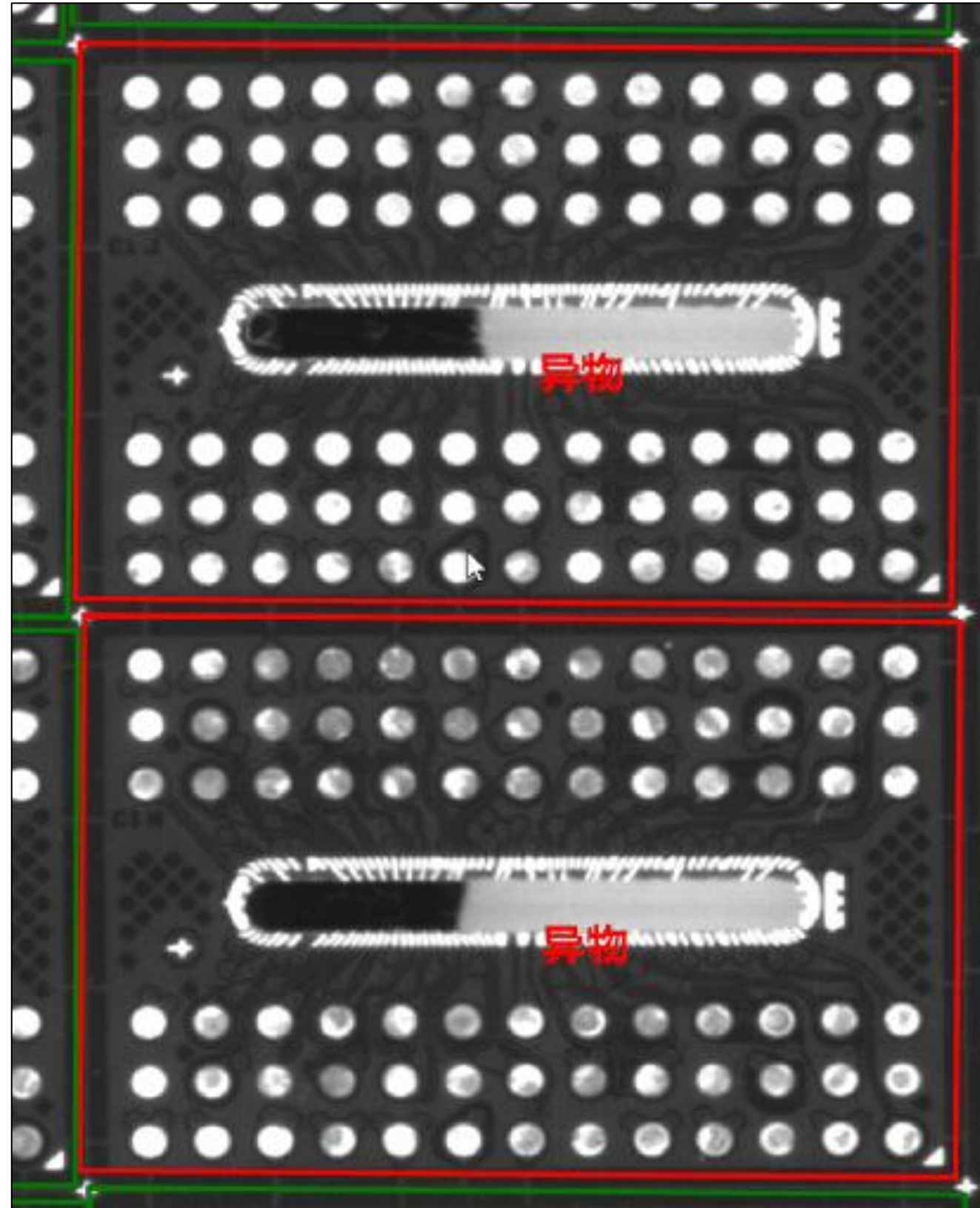

Foreign Object

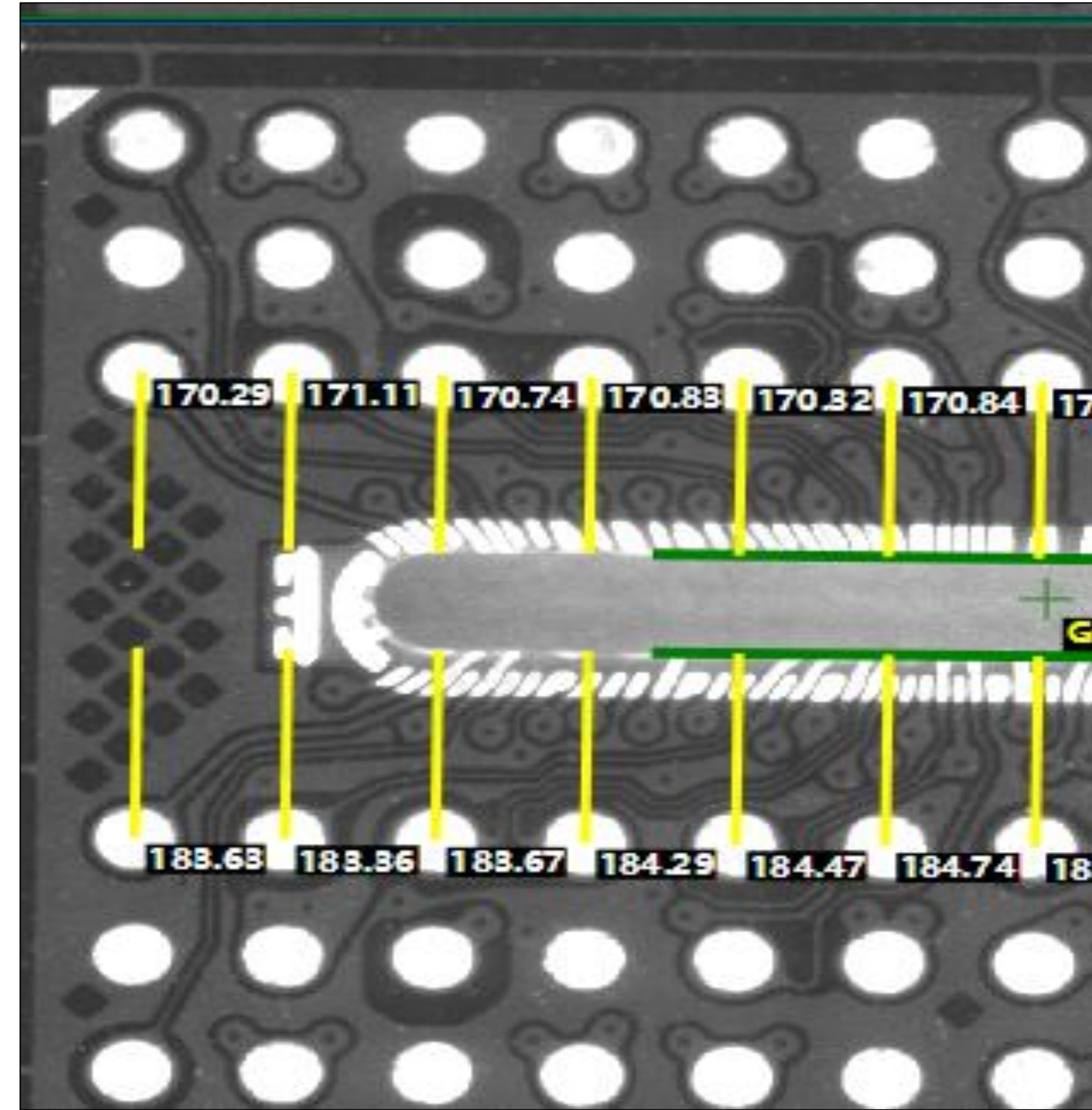

Slot offset (SW)

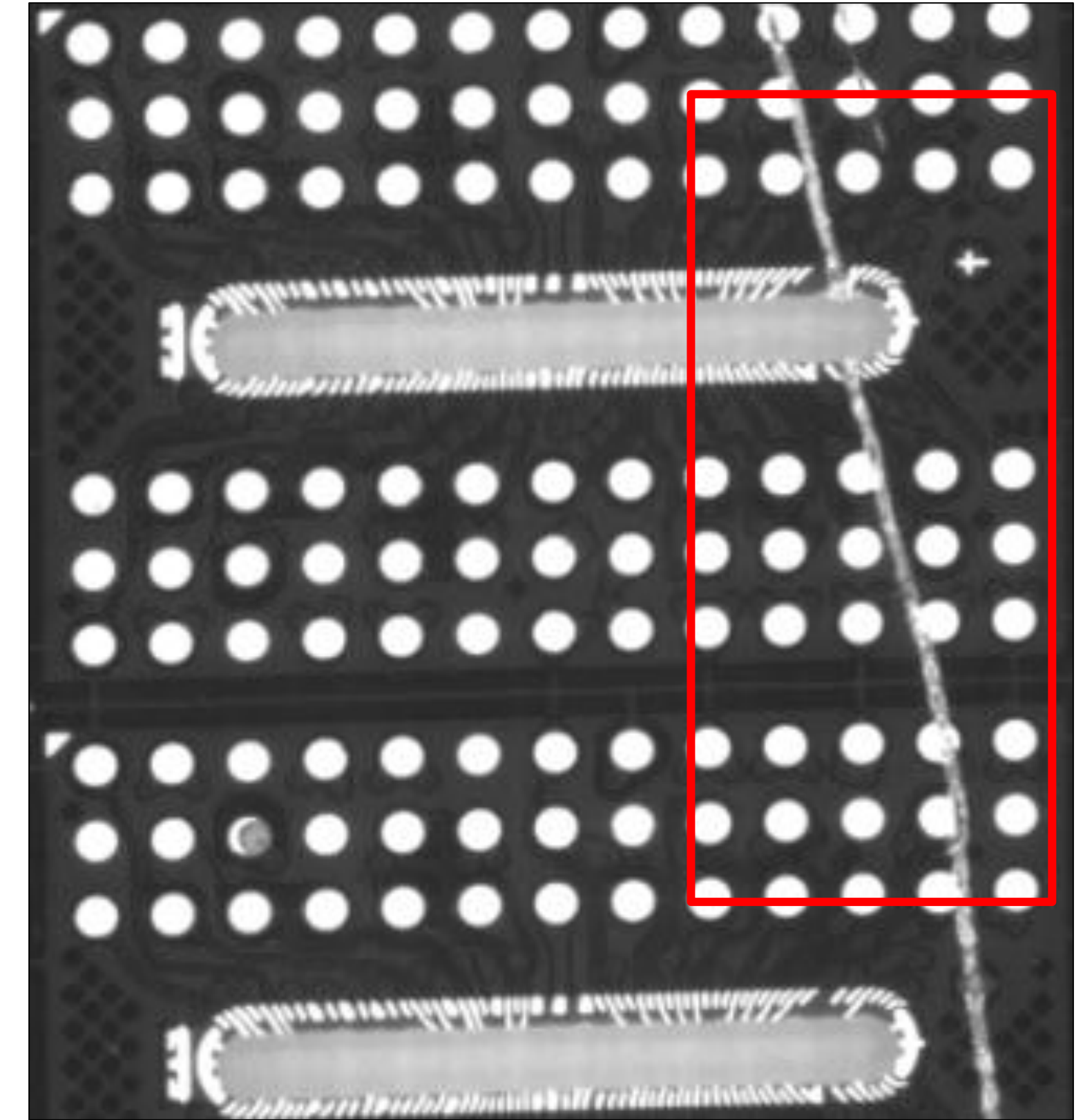

Scratch

| | |
|-------|----------------------------|
| CIS | 1,800dpi, Mono, FOV: 328mm |
| Light | CIS용 일반 내부 조명 사용 |

PCB 전용 CIS 광학 솔루션 (균일도 개선)

(일반 CIS 동축조명 사용시) 특정영역이 밝기값이 균일하지 않은 구간이 존재 함

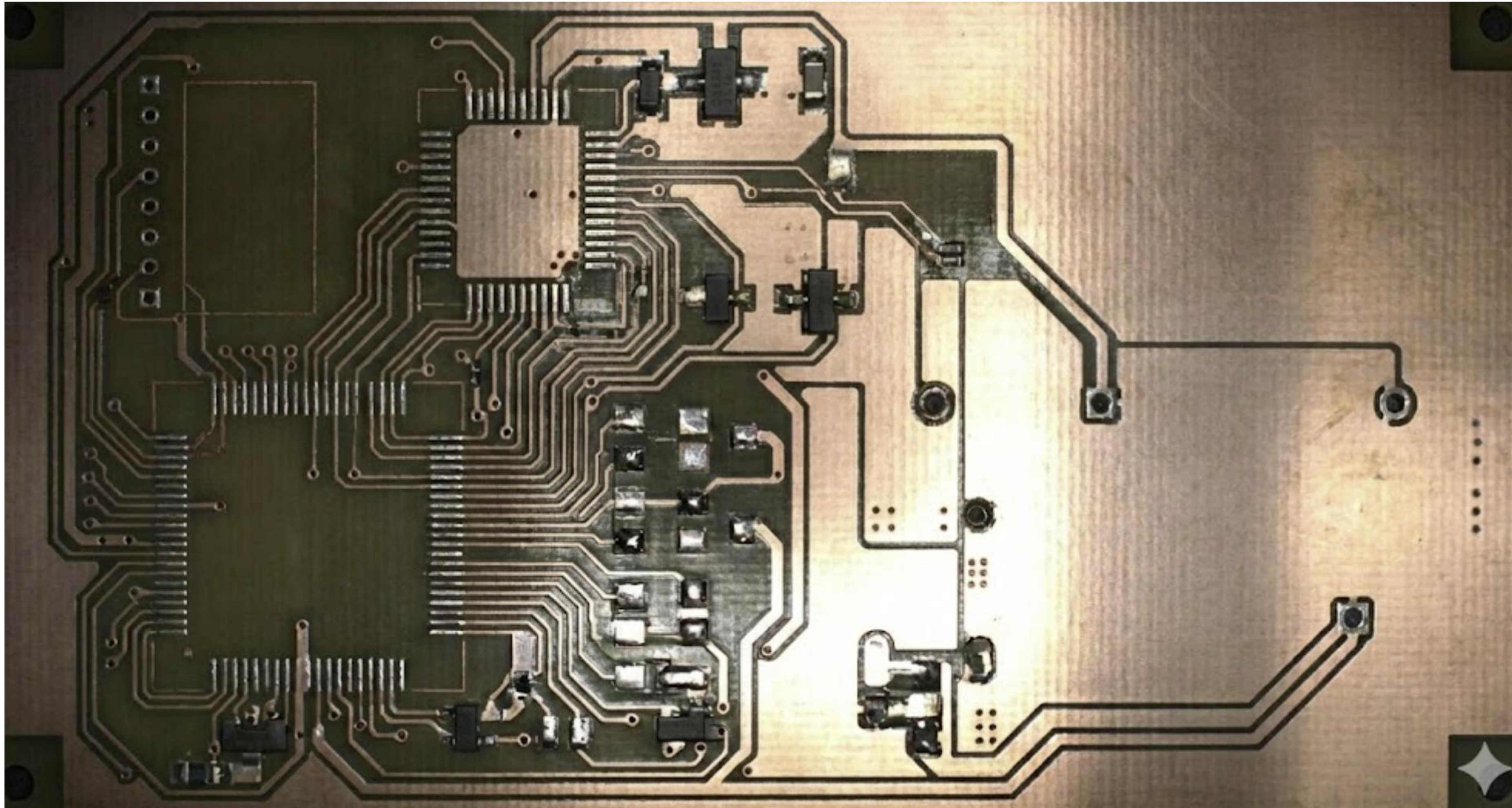

PCB 전용 CIS 광학 솔루션 (균일도 개선)



PCB 전용 CIS 광학 솔루션 (균일도 개선)

PCB전용 동축CIS조명 적용으로 전영역에서 **균일한 밝기값** 확보 가능

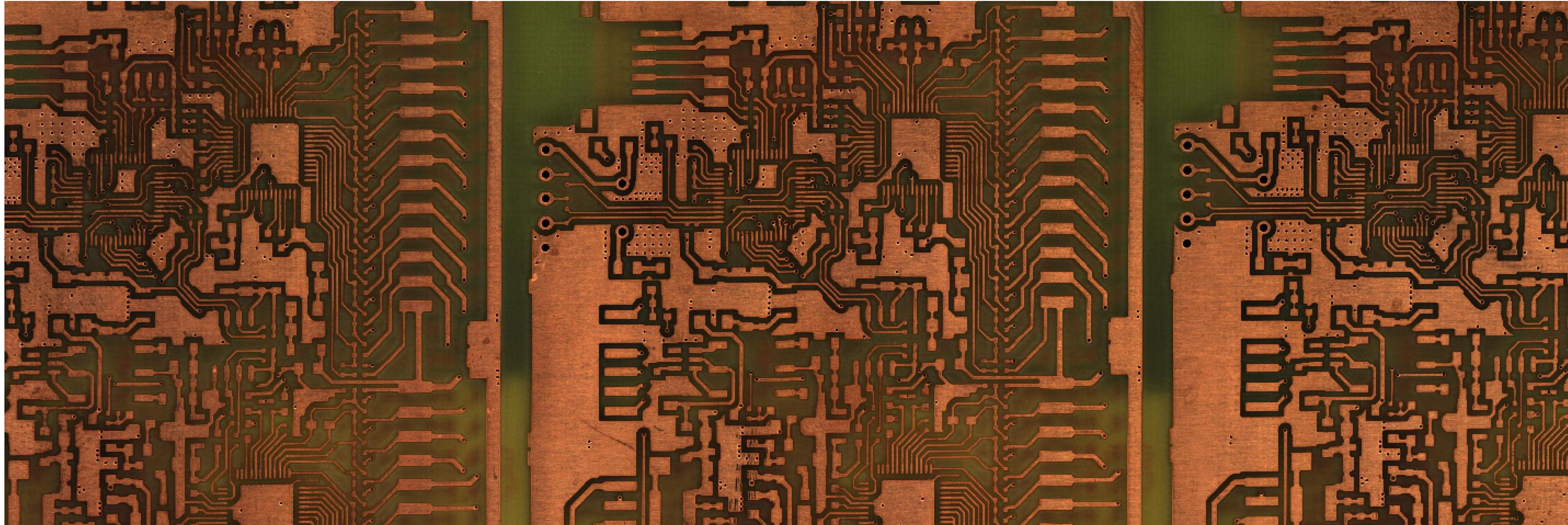

PCB 전용 CIS 광학 솔루션 (CIS사양 소개)

| 광학계 사양 | |
|---------|---|
| 해상도 | 600(48um) / 900(28um) / 1200(24um) / 1800(14um) / 3600(7um) dpi |
| 센서컬러 | 흑백 또는 컬러 |
| FOV | 50~820mm (그 이상 길이 커스텀 가능) |
| 조명LED색상 | UV / RED / Green / Blue / White / IR |
| 조명Type | 동축(Coaxial) / 외부조명 사용 가능 |

07

Application #2 : **Wafer** Inspection

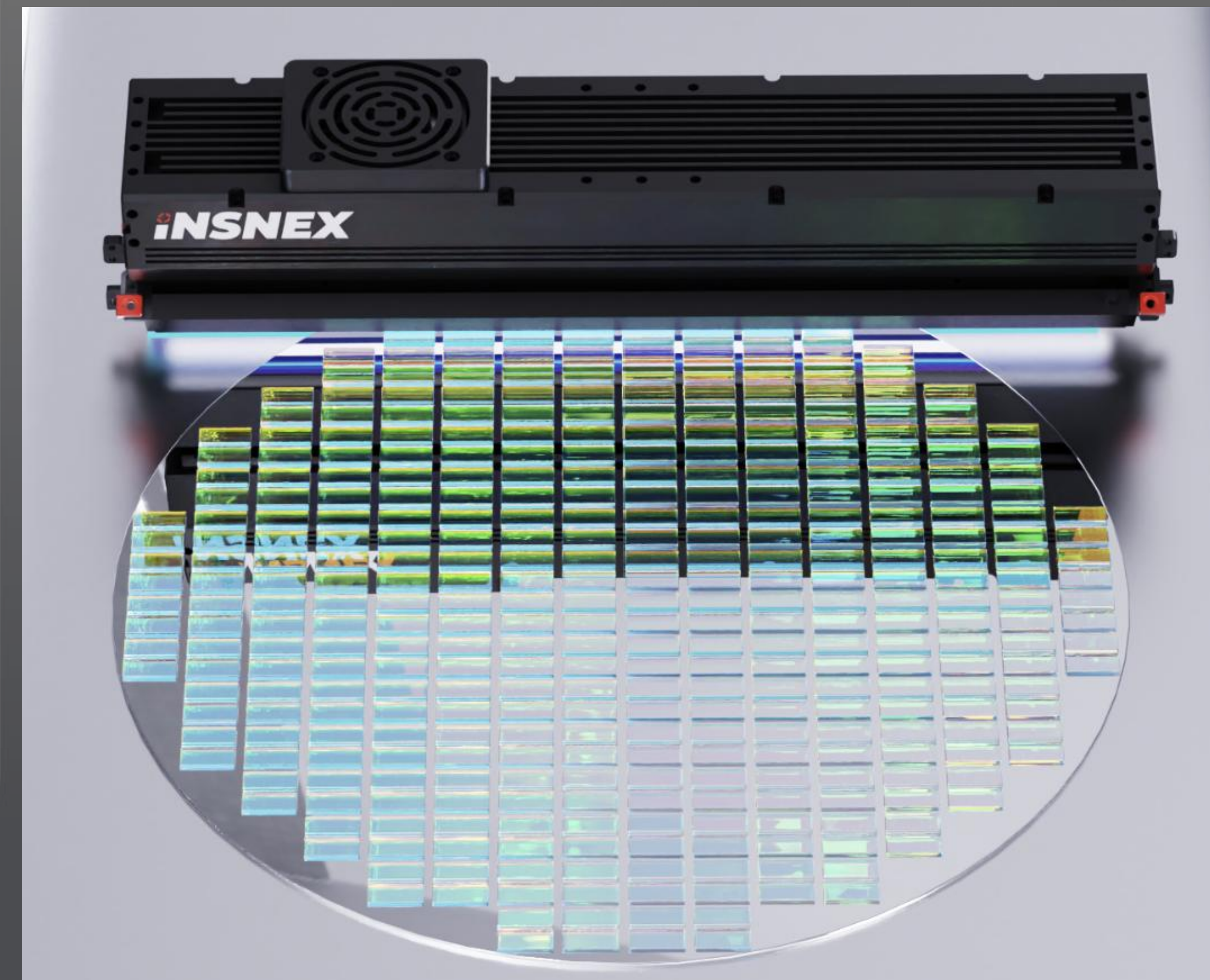

Wafer 전용 CIS 광학 솔루션 (Wafer용 동축조명)



CIS

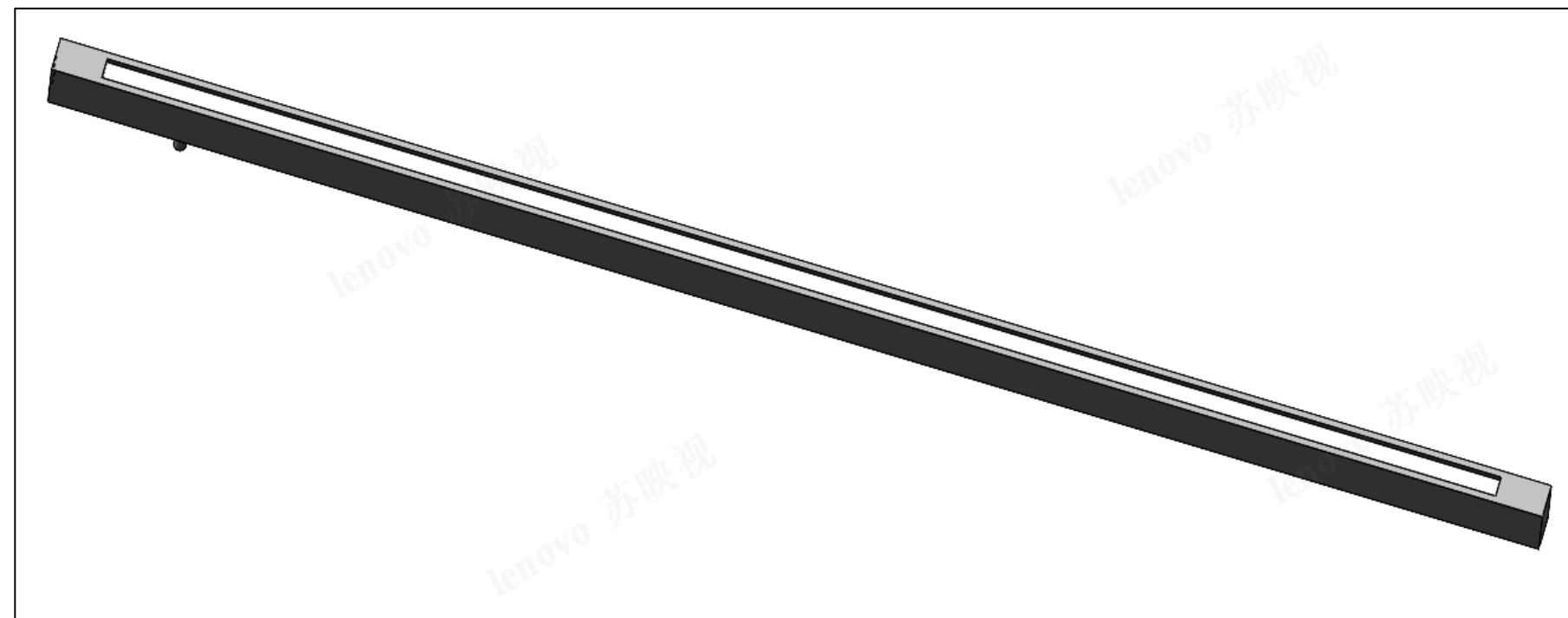
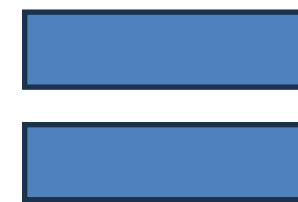
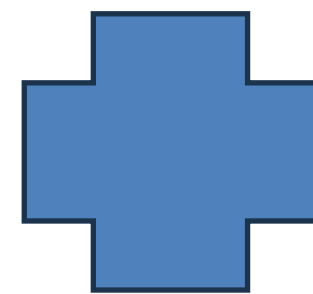

Light

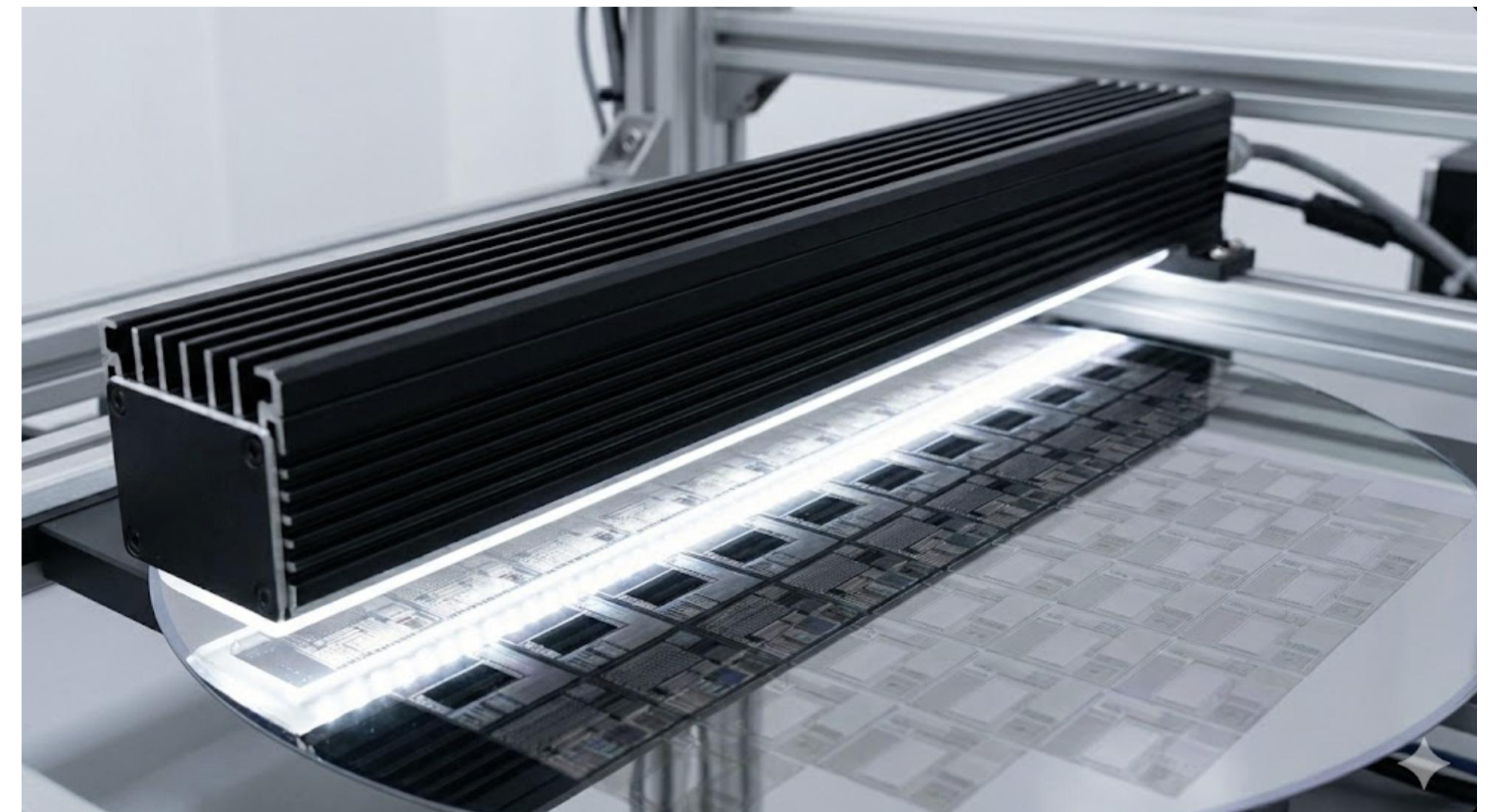

<Wafer 전용 동축 CIS 조명>

Wafer 전용 CIS 광학 솔루션 (Wafer 촬영 이미지)

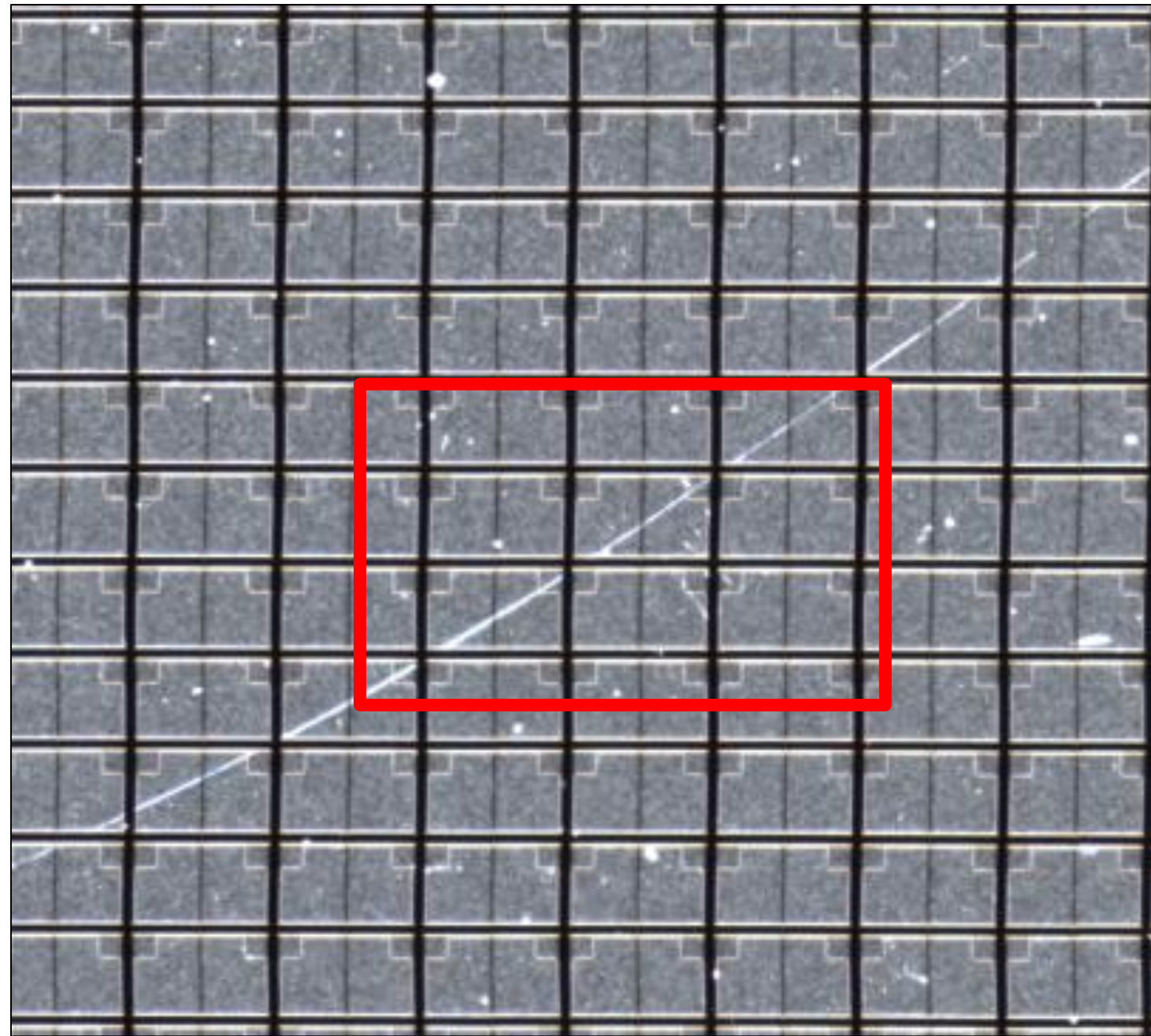

표면 스크래치

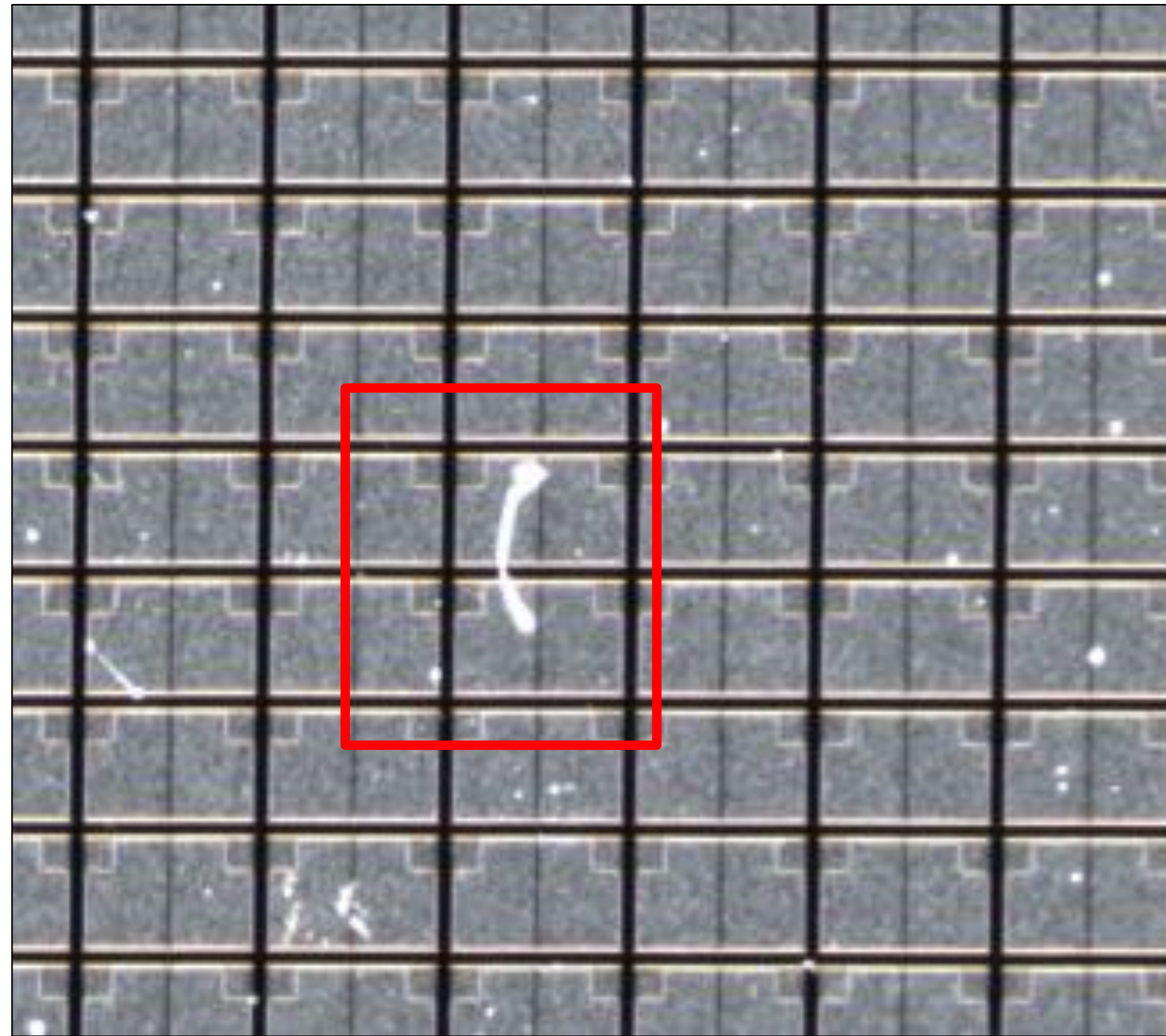

표면 얼룩

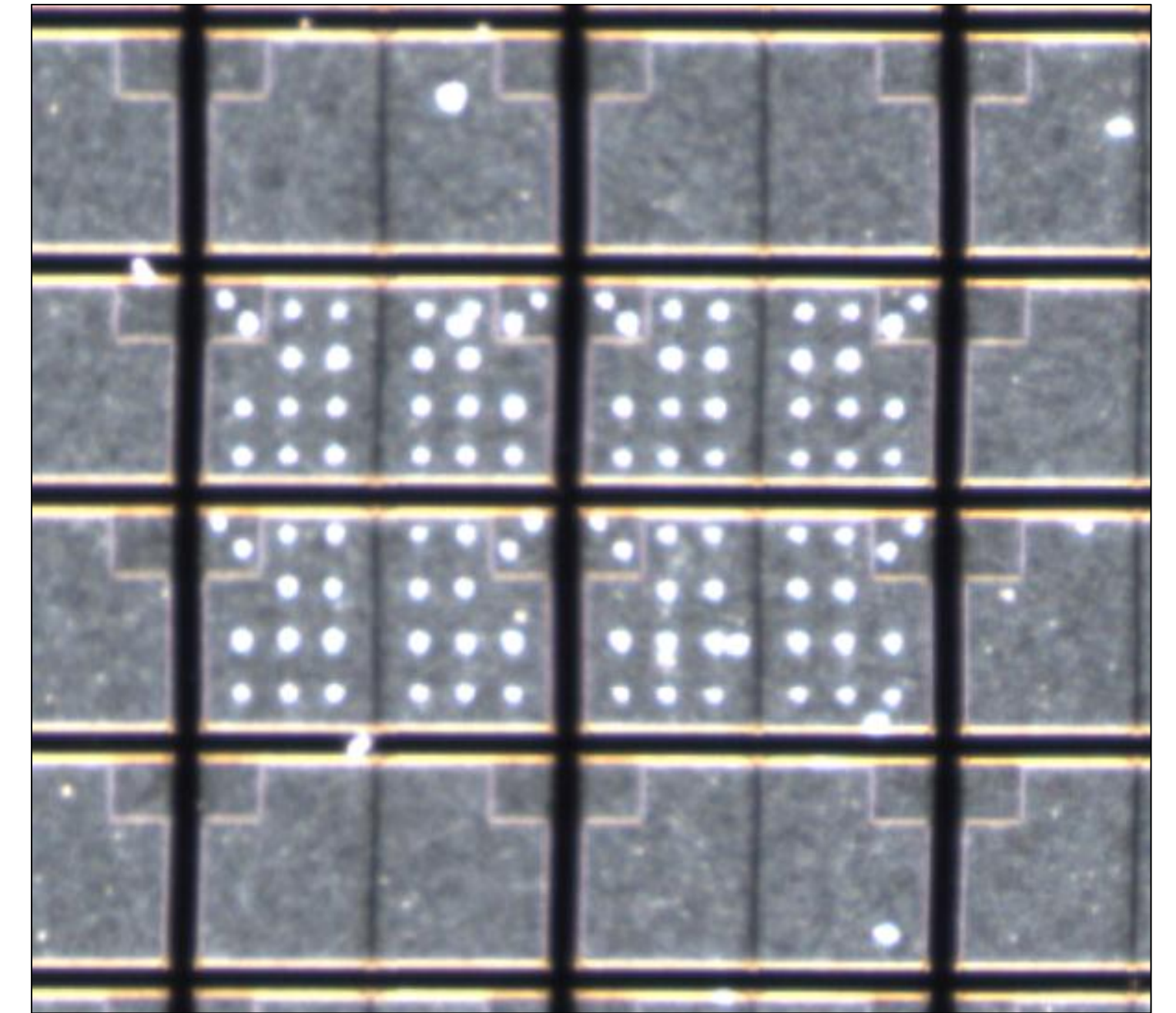

Details
(Zoomed-in)

| 촬영조건 | |
|--------|------------------------------------|
| CIS | 3,600DPI(7um), Color, 165mm, 40kHz |
| Lights | Wafer Line Light for CIS |

Wafer 전용 CIS 광학 솔루션 (Wafer 촬영 이미지)

| 촬영조건 | |
|--------|--------------------------------------|
| CIS | 3,600DPI(7um), Mono, 328mm, 40kHz |
| Lights | Wafer Coaxial Light for CIS |

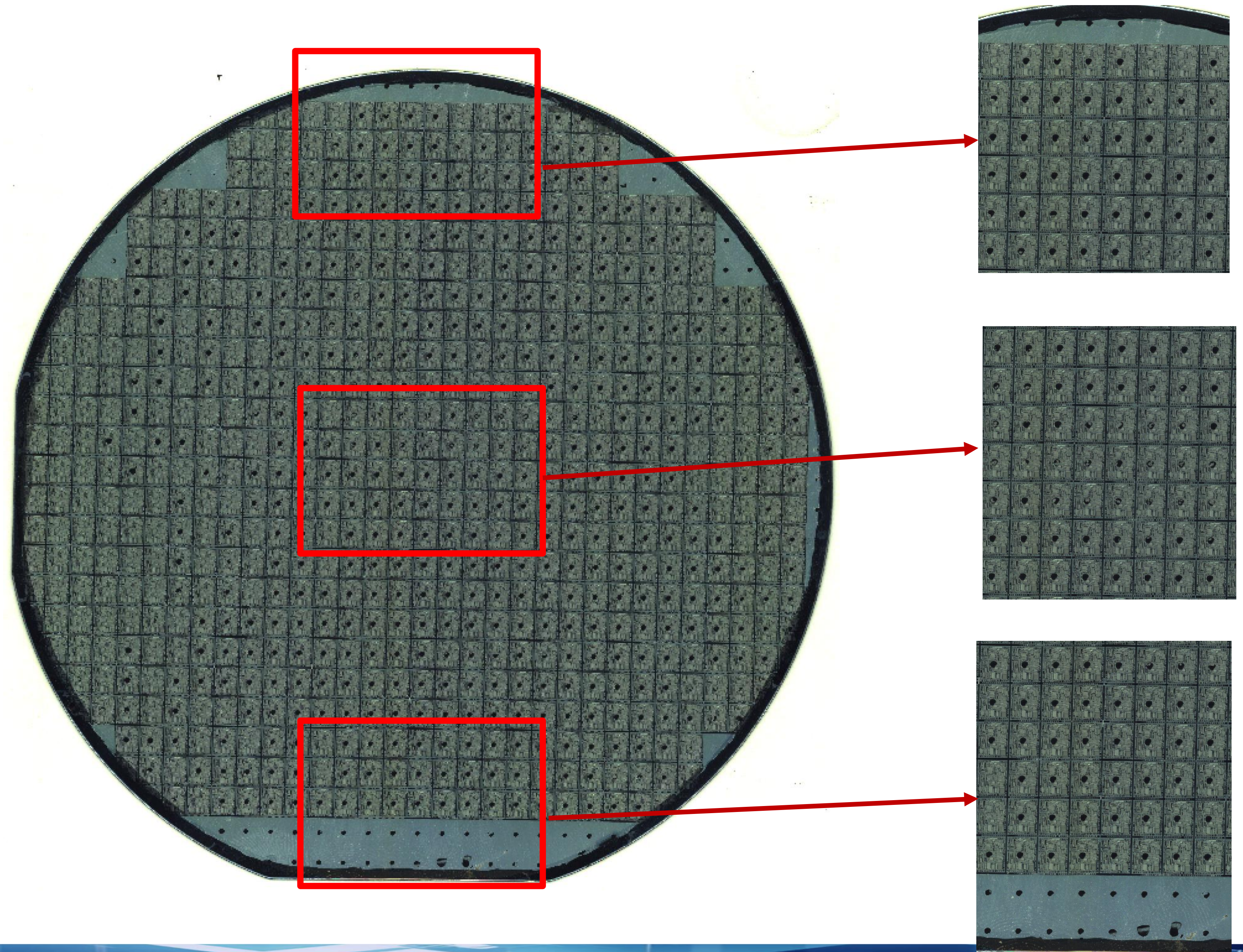

600 vs 900 vs 3,600dpi 해상력 비교 (웨이퍼)

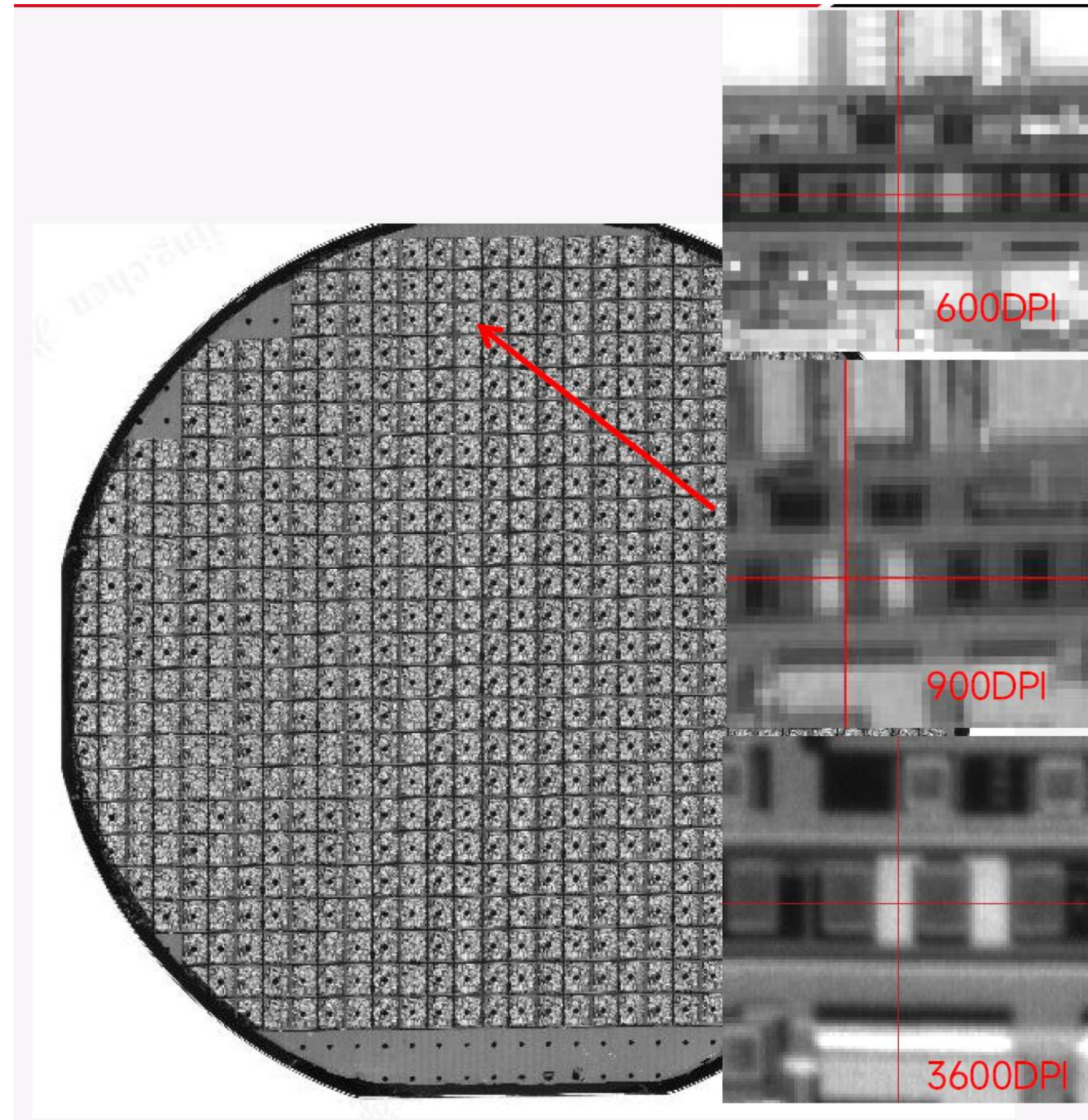

Wafer 전용 CIS 광학 솔루션 (CIS사양 소개)

| 광학계 사양 | |
|---------|---|
| 해상도 | 600(48um) / 900(28um) / 1200(24um) / 1800(14um) / 3600(7um) dpi |
| 센서컬러 | 흑백 또는 컬러 |
| FOV | 165~656mm (그 이상 길이 커스텀 가능) |
| 조명LED색상 | UV / RED / Green / Blue / White / IR |
| 조명Type | 동축(Coaxial) / CiS 내부 라인바 타입 / 플랫폼 조명 |



코엑스 B홀, B710 바이렉스

제품 문의

대표번호

T. 070-5055-3330

E-mail

ts@virex.co.kr

주소

경기도 안양시 동안구 흥안대로 427번길 38,
1214호(본사) / 1113호(개발연구실)



www.virex.co.kr

더 많은 정보와 소식은 홈페이지에서 확인하세요.