

MARS-138-95GM-P-TN-SWIR

1.3MP CMOS GigE SWIR Area Scan Camera



GEN<i>i>CAM



MARS-138-95GM-P-TN-SWIR is a SWIR camera. Equipped with the Sony IMX990 sensor using SenSWIR technology, the camera can capture wide band image information ranging from 400nm to 1700nm. MARS-138-95GM-P-TN-SWIR can replace the traditional "Visible light camera + SWIR camera" dual camera detection scheme. The wide spectral band is suitable for multispectral applications, while the high frame rate of the camera is very suitable for semiconductor inspection applications.

Applications

Suitable for machine vision applications such as industrial inspection, medical, scientific research, education and so on.

Features

- Acquisition Burst Mode
- Stamp, ROI, Binning, Decimation, Reverse X/Y, Sequencer Control
- Timer, Counter, LUT, User Set Control
- Gamma, Black Level, Digital Shift
- Remove Parameter Limit
- Static Defect Correction, Fixed Pattern Noise Correction, Sharpness, Noise Reduction,
- Flat Field Correction(FFC), DSNU Control, PRNU Control

Spectral Response

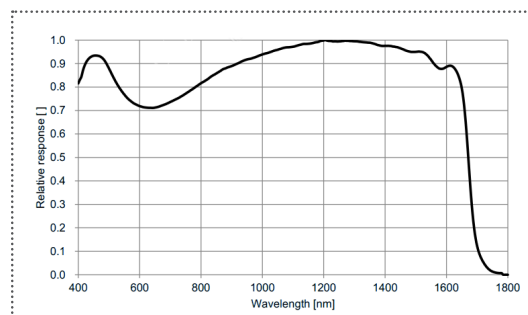

Specifications

Model	MARS-138-95GM-P-TN-SWIR
Resolution	1280(H) × 1024(V)
Sensor	Sony IMX990 Global shutter CMOS
Sensor Format	1/2"
Pixel Size	5μm × 5μm
Frame Rate	89.7fps (Under acquisition burst high speed mode, acquisition frame rate up to 134fps at sensor bit depth BPP8)
ADC	8 bit, 10 bit, 12 bit
Pixel Bit Depth	8 bit, 10 bit, 12 bit
Mono/Color	Mono, SWIR
Pixel Formats	Mono8 / Mono10 / Mono12 / Mono10Packed / Mono12Packed
SNR	50.4 dB
Exposure Time	Ultra short: 3μs~100μs, Actual Steps: 1μs; Standard: 13μs~1s, Actual Steps: 1 row period
Gain	0dB~24dB, Default: 0dB, Step: 0.1dB
Binning	1×1, 1×2, 2×1, 2×2
Decimation	Sensor: 1×1, 2×2
Synchronization	Hardware trigger, software trigger
Acquisition Control	Single frame, Continuous, Software trigger, Hardware trigger
Reverse X/Y	Reverse X/Y
I/O Interface	1 input and 1 output with opto-isolated, 1 programmable GPIO
Data Interface	GigE PoE
Power Supply	12VDC-10% ~ 24VDC+10% supplied via the camera's Hirose connector or PoE (Power over Ethernet, IEEE802.3af compliant)
Power Consumption	13W @ Max. cooling
Operating Temp.	0° C ~ +45° C
Storage Temp.	-20° C ~ +70° C
Operating Humidity	10% ~ 80%
Cooling Method	Thermoelectric Cooling (TEC)
Cooling Temp.	Typ.: 15° C ±0.5° C below ambient temp. @room temp.
Lens Mount	C
Filter / Transparent glasses	-
Dimensions	58(W) × 58(H) × 75.5(L) mm
Weight	407 g
Software	3rd-party software such as HALCON, VisionPro and LabVIEW
OS	32bit / 64bit Windows, Linux, Mac OS
Conformity	CE, RoHS, GenICam®, GigE Vision®

I/O Interface



Pin	Definition	Description
1	Line0+	Opto-isolated input +
2	GND	PWR GND & GPIO GND
3	Line0-	Opto-isolated input -
4	POWER_IN	Camera external power +12V DC ~ +24V DC
5	Line2	GPIO input/output
6	RS232 Rx	RS232 receive*
7	Line1-	Opto-isolated output -
8	Line1+	Opto-isolated output +
9	GND	PWR GND & GPIO GND
10	GND	PWR GND & GPIO GND
11	POWER_IN	Camera external power +12V DC ~ +24V DC
12	RS232 Tx	RS232 transmit*



- 1) The polarity of GPIO pins and power cannot be reversed, otherwise, the camera or other peripherals could be burnt out.
- 2) This model has high power consumption and both pairs of power and ground must be fully connected to the external power
- 3) *Available for some models

Technical Drawing

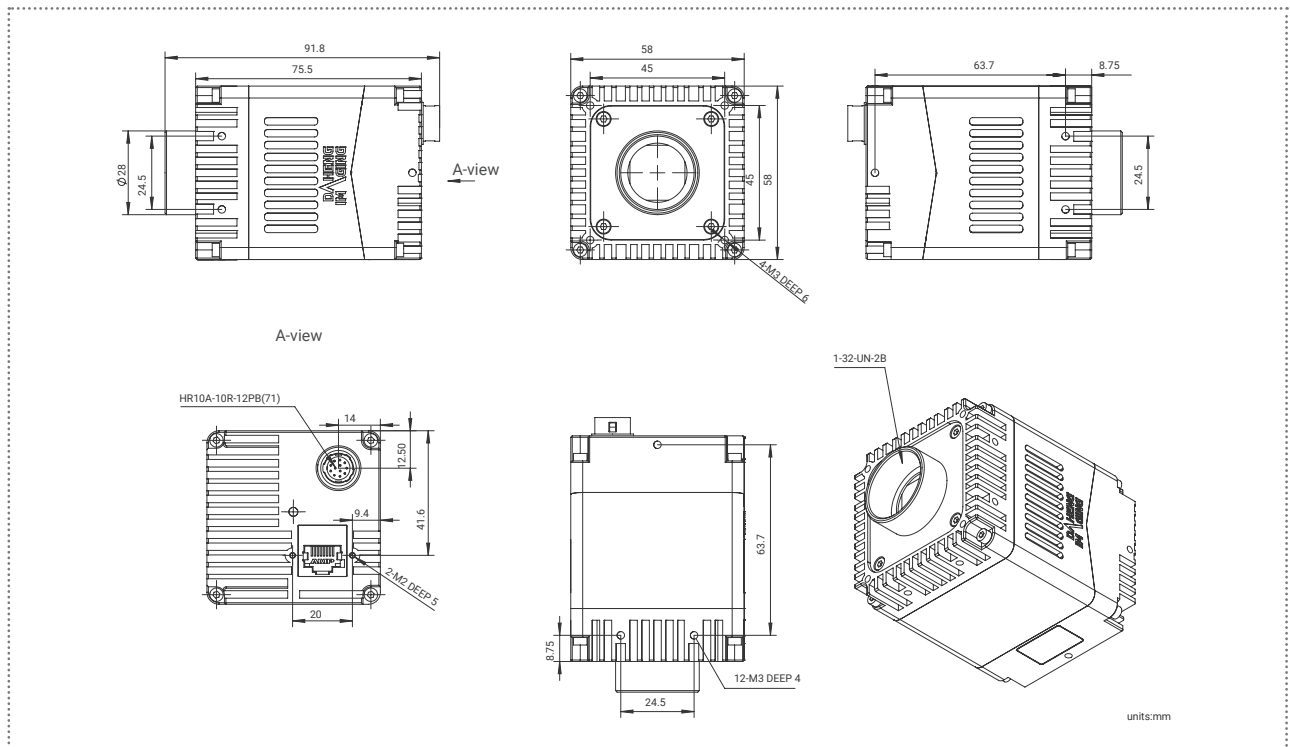

China Daheng Group, Inc. Beijing Image Vision Technology Branch

12F Daheng Science & Technology Tower, No.3 Suzhou Street, Haidian District, Beijing China, 100080

Tel: +86 10 82828878

E-mail: isales@daheng-imaging.com